



**Tallgrass  
Technologies**  
Corporation

**SOFTWARE  
INSTALLATION INSTRUCTIONS  
and  
OPERATIONS MANUAL**

**FOR MODELS  
TG-3006 TG-3012 TG-3020  
TG-3135 TG-3170**

TALLGRASS reserves the right to make changes to the products described in this document in order to improve the design or performance and to supply the best possible products. TALLGRASS assumes no responsibility for the use of this product in any application, conveys no license under any patent or other right, and makes no representation that any application contained herein is free from patent infringement. Any application contained in this publication is presented for illustration purposes only and TALLGRASS makes no warranty that such applications will be suitable for the use specified without further testing or modification. Reproduction of any portion of this publication without the prior written consent of TALLGRASS is prohibited.

First Edition - June, 1983

©Copyright by Tallgrass Technologies Corporation, 1983

First Printing - July, 1983

Second Printing - August, 1983

Third Printing - September - 1983

Fourth Printing - October, 1983

Fifth Printing - December, 1983

Sixth Printing - March, 1984

TALLGRASS TECHNOLOGIES CORPORATION

Operation Manual for Models:

TG-3006      TG-3012      TG-3020

TG-3135      TG-3170

Copyright 1983 by TALLGRASS TECHNOLOGIES CORPORATION.

All Rights Reserved.

WARNING

This equipment generates, uses and can radiate radio frequency energy. As temporarily permitted by regulation, it has not been tested for compliance with the limits for Class A computing devices pursuant to Subpart J or Part 15 of FCC Rules, which are designed to provide reasonable protection against interference. Operation of this equipment in a residential area is likely to cause interference in which case the user at his own expense will be required to take what ever measures may be required to correct the interference.

Please direct all comments concerning this manual to:

Tallgrass Technologies  
11667 W. 90th St.  
Overland Park, Kansas 66214

Attn. Technical Support/Documentation

## Preface

This guide provides a complete series of procedures for the installation, configuration, and operation of the TALLGRASS HardFile Subsystem. The user of this system must introduce new hardware and new software as outlined in this guide.

This publication contains seven chapters:

Chapter One. Hardware Installation, covers selection of an appropriate power source and operating environment, determination of hardware modification requirements, and installation of the Interface Circuit Board.

Chapter Two. Software Installation, covers configuring the HardFile, selecting of system software options, and creating the integrated system "TALLGRASS Boot Diskette".

Chapter Three. HardFile Diagnostics, describes various tests and procedures available for operational use at the HardFile System level.

Chapter Four. Backing-Up On Tape, instructs the user on fundamentals of the tape system and user application programs for tape backup. Both Streaming and File-By-File methods are discussed.

Chapter Five. Having Trouble?, assists in locating and correcting problems associated with installation and normal operation of the system.

Chapter Six. Maintenance, describes procedures for obtaining service on the HardFile System.

Chapter Seven. Programming Notes, provides hints to the new user for full utilization of your system.

NOTES

## Introduction

This manual provides detailed procedures for installing, configuring, and operating your new system.

Your new TALLGRASS HardFile Subsystem brings powerful Winchester mass storage technology and streaming tape backup to the Personal Computer. The options available allow customized design of the HardFile configuration. Wide versatility is available in adapting your system to the needs and requirements of your own applications.

The installation and configuration exercises in this manual will create a customized "TALLGRASS Boot Diskette". Using the procedures outlined, you will find your new integrated system performing your specific application requirements through this newly created "TALLGRASS Boot Diskette".

NOTES



## Table Of Contents

	page
Preface .....	I
Introduction .....	II
Table of Contents .....	III
Warranty Terms and Policy .....	VI
Specifications Summary .....	VIII
Chapter One - Hardware Installation.....	1-8
1-1 The Power Source.....	1
1-2 The Operating Environment ...	1
1-3 Your PC Configuration .....	2
1-4 Interrupt Request .....	3
1-5 I/O Addresses .....	5
1-6 Installing The Interface Circuit Board .....	5
1-7 Power Up .....	7
Chapter Two - Software Installation.....	9-21
2-1 TALLGRASS Software Diskette..	9
2-2 The TGSYS Program .....	11
2-3 Verify Read After Write .....	17
2-4 Duplicate Directory .....	18
2-5 Cache Memory .....	18
2-6 Landing Zone .....	19
2-7 Drive Designations .....	19
2-8 Allocation Unit Size .....	20
2-9 Directory Size .....	21
Chapter Three - HardFile Diagnostics.....	23-29
3-1 The UTILITY Program .....	23
3-2 The SPEEDTST Program .....	27
Chapter Four - Backing Up On Tape.....	31-47
4-1 Why Use a Tape Drive? .....	31
4-2 The Tape Cartridge .....	31
4-3 The Tape Drive .....	32
4-4 Tape Drive & Tape Care.....	33
4-5 Streaming Tape Versus File-By-File .....	36
4-6 The TAPE Program .....	36
4-7 The TGTAPE Program .....	44
4-8 TGBACKUP .....	45
4-9 TGRESTOR .....	46
4-10 TAPEDIR .....	47

Table Of Contents (con't)

Chapter Five - Having Trouble?.....	49-52
5-1 HardFile System Trouble Chart .....	49
5-2 Audible Error Codes .....	51
5-3 DOS Error Codes .....	51
5-4 Technical Support .....	52
5-5 Application Software .....	52
 Chapter Six - Maintenance.....	 53-54
6-1 Replacement Parts .....	53
 Chapter Seven - Programming Notes.....	 55
7-1 DMA Operation .....	55
7-2 I/O Addresses 280H - 285H .....	55
 Appendix I - Glossary.....	 57
Appendix II - Technical Support Bulletins.....	61
Appendix III - Additional Operating Notes.....	63
Appendix IV - Interface Requirements.....	65

## Warranty Terms and Policy

TALLGRASS Technologies uses the highest quality components available today in manufacturing the industry's finest mass storage systems. Our quality assurance program minimizes field component failure and provides system reliability largely unavailable in the microcomputer industry. The TALLGRASS standard product warranty covers parts and labor on all components excluding tape cartridges for a period of 90 days from documented date of sale. In most cases your authorized TALLGRASS supplier will perform any required service.

**IMPORTANT: IN ORDER TO VALIDATE YOUR WARRANTY, FILL OUT AND RETURN THE WARRANTY REGISTRATION CARD WITHIN 10 DAYS OF PURCHASE DATE.**

To return any defective equipment to TALLGRASS, a FAILURE REPORT Form must be attached prior to returning it to the factory. In addition, a RETURNED MATERIALS AUTHORIZATION (RMA) Number must be obtained from TALLGRASS. Any returned equipment must be sent to TALLGRASS freight prepaid, and the shipping container must prominently display this RMA number. The equipment will be Repaired or Replaced at the option of TALLGRASS, and will be returned to you freight prepaid. Should TALLGRASS' examination and testing not disclose any defect, TALLGRASS will so advise you and you will reimburse TALLGRASS \$75 for the testing and handling expenses incurred.

For equipment incorporating a factory sealed enclosure containing, but not limited to, disks and heads, this warranty is deemed voided if the enclosure has been opened or shows evidence of an attempt to be opened. For equipment incorporating accelerometers to monitor for mishandling, TALLGRASS reserves the right to automatically exclude from warranty coverage any drive whose accelerometer indicates excessive shock due to mishandling or shipment in other than the original TALLGRASS-supplied shipping containers.

Equipment should be shipped only in the shipping container it was originally supplied in. If replacement shipping containers are required contact TALLGRASS Customer Services to arrange for containers to be supplied.

**CAUTION: SHIPPING HARD DISK OR TAPE EQUIPMENT IN OTHER THAN FACTORY-SUPPLIED CONTAINERS WILL VOID THE WARRANTY.**

TALLGRASS will for no purposes be deemed to have any liability with respect to data contained in any equipment placed in its possession.

This warranty is contingent upon proper use in the application for which the equipment was intended and does not cover equipment which was modified without TALLGRASS' approval or which was subjected to unusual physical or electrical stress.

EXCEPT FOR THE EXPRESS WARRANTY SET FORTH, TALLGRASS GRANTS NO OTHER WARRANTY, EITHER EXPRESSED OR IMPLIED, ON EQUIPMENT, INCLUDING ALL IMPLIED WARRANTIES OF MERCHANTABILITY OR FITNESS, AND THE STATED EXPRESS WARRANTY IS IN LIEU OF ALL LIABILITIES OR OBLIGATIONS OF TALLGRASS FOR DAMAGES INCLUDING, BUT NOT LIMITED TO, CONSEQUENTIAL DAMAGES OCCURRING OUT OF OR IN CONNECTION WITH THE USE OR PERFORMANCE OF TALLGRASS' PRODUCT.

Specifications Summary

	TG-3006	TG-3012	TG-3020	TG-3135	TG-3170
HardFile	1	2	2	3	4
Platters	2	4	4	5	7
Heads	306	306	480	697	987
Cylinders	612	1,224	1,920	3,485	6,909
Tracks					
Storage Capacity (bytes)					
-unformatted					
Per track	10,922	10,922	10,922	10,922	10,922
Per cylinder	21,844	43,688	43,688	54,610	76,454
Per head	10,922	10,922	10,922	10,922	10,922
Per drive	6,684,264	13,368,528	20,970,240	38,063,170	75,460,098
-formatted					
Per track	10,240	10,240	10,240	10,240	10,240
Per cylinder	20,480	40,960	40,960	51,200	71,680
Per head	10,240	10,240	10,240	10,240	10,240
Per drive	6,266,880	12,533,760	19,566,800	35,686,400	70,748,160
Performance					
rot. speed	3,600	3,600	3,600	3,600	3,600
avg. latency (ms)	8.33	8.33	8.33	8.33	8.33
transfer rate (Mb/s)	5.09	5.09	5.09	5.09	5.09
seek, avg. (ms)	3.00**	3.00**	3.00**	9.00***	10.00***
seek, max (ms)	85	85	120	45	30
seek, max (ms)	205	205	310	90	80
Type Drive					
Tracks	4	4	4	9	9
Transfer rate (bits/s)	900K	900K	900K	900K	900K
Formatted capacity	12 Mbyte	12 Mbyte	12 Mbyte	45 Mbyte	45 Mbyte
Recording density (RPI)	10,000	10,000	10,000	10,000	10,000
Recording code	GCR	GCR	GCR	GCR	GCR

Recoverable error rate\* not more than one in 10<sup>8</sup>-8  
 Non-recoverable error rate\* not more than one in 10<sup>6</sup>-10

\*Assumes use of certified, defect-free qualified media \*\* Without settling time \*\*\* Including settling time

Disk and Tape Error Control

CRC/ECC length	40 bits
Detection span	18 bits
Correction span	8 bits
Pmc	9.1 x 10 <sup>8</sup> -13
Pmc	1 x 10 <sup>8</sup> -5

Physical size (W x H x D) TG-3000, 3100 15.0" X 5.5" X 12.5"  
 TG-4000 9" X 7.5" X 10.5"

Power requirements 107-127 or 214-254 VAC +/- 5%, 60 watts maximum  
 Environmental requirements 50-90 degrees F. recommended  
 ambient temperature 8-80% non-condensing  
 relative humidity maximum wet bulb 75 degrees F. non-condensing

NOTES

## Chapter One

### Hardware Installation

#### 1-1

#### The Power Source

When installing the TALLGRASS HardFile System, consider where to obtain power to operate the system. Although the HardFile is equipped with electronic switching power supplies that provide precisely regulated D.C. voltage for the internal components, like your Personal Computer the HardFile is still not immune to power interruptions or disturbances. Air-conditioners, water-coolers, copying-machines and other motor-driven devices may cause unreliable operation if connected on the same power circuit.

If you choose to operate your HardFile with an emergency- or "uninterruptable-" power supply system, be sure to choose a system that switches to backup power within four cycles or 64 milliseconds.

Before installing the HardFile System, insure that the A.C. power receptacle for your system delivers 107 to 127 volts A.C. at 50 or 60 Hertz. If the power available at the receptacle is consistently lower than 110 volts, the HardFile can be adjusted to accommodate a low line condition of 98 to 118 volts. This change must be performed by qualified service personnel. If the A.C. line voltage input to the HardFile is too high, the internal power supply regulators will overheat; if the voltage is too low, power supply output will be poorly regulated causing abnormal HardFile operation. Since the internal components of the system operate from D.C. power, HardFile operation is not dependent on power line frequency.

The A.C. power circuits of the HardFile System can also be adjusted for European power in the range of 196 to 254 volts, 50 or 60 Hertz.

#### 1-2

#### The Operating Environment

Like all electronic equipment, the reliability of the TALLGRASS HardFile System can be influenced by certain environmental conditions. Below are some recommendations to obtain maximum reliability and performance from your HardFile System.

1. When installing the HardFile System, be sure there is adequate ventilation to allow air to flow freely through the cabinet. Avoid placing any object on top of or underneath the HardFile cabinet that would obstruct the flow of air. EXCESSIVE HEAT MAY CAUSE THE HARDFILE ERROR RATE TO DETERIORATE.
2. Place the HardFile System on a sturdy work surface. Excessive vibration or shock can not only cause errors, but may result in permanent damage to HardFile System.
3. When transporting the HardFile System, be sure to pack it in the original shipping container. This container is designed to protect the HardFile System from vibration and shock.

THE WARRANTY WILL NOT BE HONORED ON EQUIPMENT THAT HAS NOT BEEN TRANSPORTED IN A TALLGRASS SHIPPING CONTAINER.

4. Do not allow foreign objects to enter the HardFile cabinet through the ventilation holes. Metal items such as coins or paper clips will cause damage to the internal components.

### 1-3 Your PC Configuration

At least 128K of RAM must be available in your Personal Computer to operate the HardFile.

There are several peripherals and hardware options available for the PC which will enhance the operation of your total system. These accessories are not always compatible with each other. Sometimes these devices and the HardFile may interfere with one another, causing unreliable operation of one or both devices. The HardFile and the TALLGRASS Software can be adjusted to co-exist with other devices that may be sharing the the I/O Channel Interface Bus. Slight alteration of the TALLGRASS Interface Circuit Board and a corresponding patch to the TALLGRASS Software should allow the HardFile System and the other devices to respond normally. Refer to "Interrupt Request" and "I/O Addresses" in this chapter. Refer to Chapter Seven, "Programming Notes", for a discussion of DMA Channels.

The installation and operation manuals for the particular peripherals or hardware options you are using in your system usually contain compatibility information. If in doubt as to whether or not your current PC configuration is compatible with the HardFile System, contact the manufacturers of the other devices used in your configuration.



The TALLGRASS HardFile System is shipped from the factory set to use Interrupt Request #3 (IRQ3). This I/O signal is available at pin B25 of any of the I/O address connectors. If any other device in your Personal Computer uses IRQ3, (such as "COM2:", serial interfaces, etc.) unreliable HardFile operation will result. If this situation arises, either the device using IRQ3 or the HardFile will have to be moved to one of the other IRQ signals. If you decide to move the HardFile System, refer to the following steps:

1. Determine which IRQ signal is available for use in your particular configuration. Note that IRQ3 thru 7 are available for selection on the TALLGRASS Interface Circuit Board. IRQ 0 and 1 are dedicated to internal use by the System Unit (Table 1.1).

#### Typical Interrupt Request Assignments

IRQ#	Assigned to:
0	System Unit Refresh
1	Counter Timer/Speaker
2	Orchid Tech. "PC-NET"
3	COM2: , TALLGRASS HardFile
4	COM1:
5	IBM Fixed Disk Controller, Orchid Tech. "PC-NET"
6	IBM Diskette Controller
7	Parallel Printer

Table 1.1

2. Locate the TALLGRASS Interface Circuit Board. If you have already installed the Interface Circuit Board in the System Unit of the PC, turn off the power to your PC and remove the Interface Circuit Board from the System Unit.
3. On the component side of the Interface Circuit Board, (the side of the board where the integrated circuits are mounted) observe the block of pins just above the gold-plated edge connector. The pair of pins located furthest away from the black plastic interface connector has a solderless jumper that electricly connects the pair together. This jumper will slide off the pin pair and can be reinstalled on adjacent pin pairs. This is how the Interrupt Request signals are selected. Refer to Figure 1.1 .

- Determine from Figure 1.1 which pin pair enables the IRQ# you will be using on the HardFile System. Install the jumper on the appropriate pin pair. When you are sure that you have selected the correct Interrupt Request signal, install (or reinstall) the Interface Circuit Board. Refer to "Installing the Interface Circuit Board", Section 1-6.

Perform the following steps to patch the TALLGRASS software:

- Refer to your DOS Operation Guide for use of the DEBUG Program. Using DEBUG, change offset location XXXXH (refer to Table 1.2 for location) in the TALLGRASS TGTBIO.COM file of the diskette that came with the HardFile, from a value of 03 to the IRQ# you have selected; i.e. if you have selected IRQ5, then change the value at offset location XXXXH to 05.
- When you are sure that you have patched the correct offset location, remove the "Write Protect" tab from the TALLGRASS Software Diskette and use the DEBUG "W" command to write the patched file onto the TALLGRASS Software Diskette. Reinstall the write protect tab. Remember, this diskette is a "master" diskette.

It is also possible to patch the TALLGRASS version of CPM-86 support software. In this case, the DDT-86 (the CPM-86 debugger) program should be used to change the contents of offset location XXXXH in the WINCH.COM file.

SOFTWARE VERSION	TG 3.XX for PC-DOS	TG 4.XX for PC-DOS	TG 3.XX /CPM-86	TG 3.XX /MS-DOS
FILENAME	TGTBIO.COM	TGTBIO.COM	WINCH.COM	TGTBIO.COM
LOCATION XXXXH	0172H	018BH	01E2H	0172H

TABLE 1.2

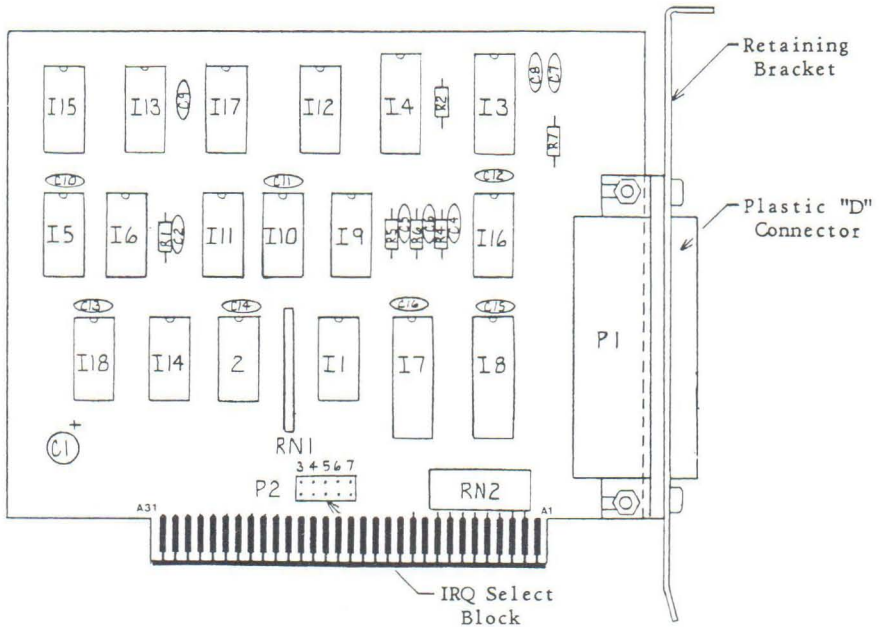

Figure 1.1 TALLGRASS Interface Circuit Board

This completes moving the TALLGRASS Interrupt Request signal.

#### 1-5 I/O Addresses

The TALLGRASS IBM-compatible Interface Circuit Board uses I/O addresses 280H thru 285H to exchange data and commands with the Personal Computer. The use of any one of these I/O addresses by other devices or software may result in unreliable HardFile operation. There is currently no software patch available to permit the use of alternate I/O addresses by the HardFile System. For programming information relavent to I/O addresses 280H thru 285H consult Chapter Seven, "Programming Notes".

#### 1-6 Installing the Interface Circuit Board

The following steps will require removal of the cover from the System Unit of your Personal Computer.

1. Turn off the System Unit of your Personal Computer and remove the plug from the A.C. receptacle. DO NOT ATTEMPT TO INSTALL THE INTERFACE CIRCUIT BOARD WHILE POWER IS APPLIED TO THE PERSONAL COMPUTER. DOING SO WILL RESULT IN DAMAGE TO BOTH THE INTERFACE CIRCUIT BOARD AND THE PERSONAL COMPUTER.
2. Remove the appropriate cabinet securing screws at the rear of the Personal Computer, so that the cabinet may be removed to expose the I/O Channel Connectors near the rear of the PC chassis.
3. Remove the screw that secures any one of the blank I/O channel retaining brackets to the rear chassis of the Personal Computer. Save the blank retaining bracket and the screw.
4. Insert the TALLGRASS Interface Circuit Board into any available I/O Channel Connector (except J8 of the XT Personal Computer), making sure the edge connector of the circuit board is properly seated in the socket.
5. Secure the retaining bracket of the Interface Circuit Board to the Personal Computer chassis with the same screw that was used to secure the blank retaining bracket.

DO NOT CHANGE THE DISK DRIVE SWITCH SETTINGS ON THE MOTHER BOARD OF THE SYSTEM UNIT. TALLGRASS SOFTWARE PROVIDES FOR THE HARDFILE DRIVE DESIGNATIONS AND IDENTIFICATION.

Installation of the Interface Circuit Board is now complete. The cover for the Personal Computer should now be reinstalled and secured and the power plug may be reinserted into the A.C. receptacle outlet.

#### Final Connections

1. Position the TALLGRASS HardFile to the left or right of the Personal Computer. Avoid straining the Interface Cable or pulling it taut. Do not attempt to lengthen the Interface Cable between the Interface Board and the HardFile. LENGTHENING THE INTERFACE CABLE MAY RESULT IN DETERIORATION OF THE SYSTEM ERROR RATE.

2. Connect the Interface Cable to the black plastic "D" connector protruding from the rear of the Interface Circuit Board just installed in the Personal Computer.
3. Connect the power cord into the provided socket on the rear panel of the HardFile System.
4. Insert the plug on the other end of the TALLGRASS power cord into the desired A.C. receptacle.

1-7

#### Power Up

1. Turn on the power to the System Unit of the Personal Computer and allow it to run through its usual diagnostics. Insert a DOS diskette into floppy disk drive "A>" and boot up the system.
2. Using the power switch located on the rear panel, turn on the HardFile System and observe the following:
  - a. The HardFile System will make a soft ratcheting sound. This is part of the tape drive initialization sequence. You should also hear a whirring sound emanating from the HardFile. This is the sound of the internal Hard Disk Drive spinning up to speed.
  - b. The "Decoder Error" lamp on the front panel of the HardFile System may be either on or off. The indication of this lamp becomes valid only after a Read/Write Access.
  - c. The "Head Select" lamps will be off indicating that head zero is active.

In order to reduce the possibility of erroneous control signals being sent to the HardFile System, be sure to power down the HardFile first and then the Personal Computer. Powering up the system is most reliably accomplished by turning on the Personal Computer before turning on the HardFile.

This completes installation of the TALLGRASS Interface Circuit Board. The UTILITY program (Chapter 3) will allow you to test the interface between the HardFile and the Personal Computer after you have partitioned the HardFile. Proceed to Chapter 2.

## Chapter Two

### Software Installation

#### 2-1 The TALLGRASS Software Diskette

The TALLGRASS Software Diskette, included with the Interface Package, contains programs to aid in Partitioning, Configuring, Formatting, and Testing the HardFile System. The Diskette also contains the software drivers that allow DOS to recognize the HardFile System. This software diskette should be used only as a "master" diskette, that is, do not attempt to execute the programs directly from this diskette.

Your DOS master diskette and the TALLGRASS Software Diskette will be used to create a new "TALLGRASS Boot Diskette" for use when you want to activate the HardFile System. When you boot up on a regular DOS diskette instead of the TALLGRASS Boot Diskette, the Personal Computer will behave as though the HardFile System is not connected to the System Unit.

It is recommended that you obtain a directory of the TALLGRASS Software Diskette at this time. The names of the files in the directory vary depending upon which Operating System (O/S) you are using. Table 2.1 describes which TALLGRASS Software version to use for your O/S. Listed below each O/S supported by TALLGRASS, is the appropriate TALLGRASS Software version and a list of files that will appear in the directory for each version. The files may appear in any order, but must all be present if you are to take full advantage of the software features. Finally, the last row of information in the table directs you to the section where you can obtain more detailed information and directions for running the TGSYS program associated with each TALLGRASS version.

IBM PC-DOS VERSION 1.10	IBM PC-DOS VERSION 2.00	IBM CPM-86 VERSION 1.00	T.I. MS-DOS VERSION 1.25
TG VERSION 3.XX	TG VERSION 4.XX	TG VERSION CPM-86 / 3.XX	TG VERSION MS DOS / 3.XX
UTILITY.COM TAPE.COM COPYDUP.COM TGTBIO.COM TGSYS.COM SPEEDTST.COM UNFTAPE.COM	UTILITY.COM TAPE.COM COPYDUP.COM TGTBIO.COM TGSYS.COM SPEEDTST.COM UNFTAPE.COM CONFIG.SYS	UTILITY.COM TAPE.COM TGSYS.COM WINCH.COM	UTILITY.COM TAPE.COM COPYDUP.COM TGTBIO.COM TGSYS.COM SPEEDTST.COM UNFTAPE.COM
SECTION 2-2A	SECTION 2-2B	SECTION 2-2C	SECTION 2-2D

Table 2.1

By using the Tape Backup facilities of your HardFile System to temporarily store data under your current O/S, it is possible for one HardFile installation to support more than one O/S. It is also possible for data and programs filed under the various operating systems to reside on separate disk surfaces of the same HardFile System. Changing to another O/S simply requires booting your PC on the appropriate TALLGRASS Boot Diskette and accessing only the specific HardFile surface(s).

The TALLGRASS "TGSYS" program helps partition the HardFile System and adjust the various operating parameters. It automatically determines the size of the HardFile System connected. This allows a single version of TALLGRASS Software (for the O/S selected) to be compatible with all models in the TG3000/3100 series of equipment.

Before running the TALLGRASS "TGSYS" program, you must first create a system diskette using the following step-by-step procedure:

1. Obtain a new (blank) floppy diskette.
2. Using the DOS FORMAT command, format the new diskette with the DOS on it. To use the FORMAT command, there must be a file on your DOS diskette named FORMAT.COM. Use the "/S" option on the FORMAT command to install the DOS as the diskette is being formatted. To use the "/S" option on the FORMAT command, there must be a file named SYS.COM on your DOS diskette. Refer to your DOS Operation Manual for more detailed information on the use of the FORMAT command. You can verify that DOS has been transferred to the new diskette by obtaining a directory of the new diskette and observing the presence of the file named COMMAND.COM.

When creating a system diskette under CPM-86, the "NEWDISK" command with the "\$S" option is used for formatting. Consult the CPM-86 Operation Manual.

3. Using the DOS COPY command, copy all of the files from the TALLGRASS Software diskette to the new diskette.

Example: Assuming that your system has defaulted to the A> floppy disk drive, use the following command syntax:

```
COPY *.* B:
```

(then strike the RETURN key)



Under CPM-86, the "PIP" command is used to copy files. Refer to the CPM-86 Operation Manual for more details.

4. After copying has completed, obtain a directory of the new diskette. The names of all of the TALLGRASS files should be present in addition to the DOS file named COMMAND.COM (COMMAND.COM is not used with CPM-86).

Hereafter, the new diskette just created will be referred to as the "TALLGRASS Boot Diskette". You are now ready to run the TGSYS Program to partition and configure the HardFile. Proceed to the Section indicated in Table 2.1 for the O/S you are using.

## 2-2 The TGSYS Program

Before running the TGSYS Program, a new boot diskette must be created and the Interface Circuit Board installed (Chapter 1).

The three main tasks of the TGSYS program are as follows:

1. It divides the HardFile into more than one logical disk drive (volumes) or allows the O/S to recognize the HardFile as one large drive. Combinations up to 28Mb and up to seven logical drives are possible depending on the TALLGRASS model selected. You have control over how the disk is divided. Refer to the equipment "Specifications Summary" on page VIII at the beginning of this manual to determine the number of surfaces in your HardFile.
2. It allows you to manipulate the various HardFile options (Verify Read After Write, Duplicate Directory, Cache Memory and Landing Zone) to best suit your applications.
3. It modifies the O/S (as necessary) to recognize the HardFile as you have configured it.

The following steps are required to start the TGSYS program:

1. Place the TALLGRASS Boot Diskette into drive A> of the Personal Computer. Boot the system on the TALLGRASS Boot Diskette and observe the following:
  - A. The system will report the status of the various options which should now all be OFF.

- B. The system will display a CRC (Cyclic Redundancy Check) time within the range of 11.45 to 13.98 ms (milliseconds).
- C. The system will check the HardFile motor speed and display a hex number in the range of D620 to D660. D630 is typical (D650 for TG 3135/70).
- D. The system will declare that the HardFile configuration data is not available. This is because the TGSYS program has not yet modified the DOS to recognize the HardFile.

NOTE: IF THE HARDFILE IS NOT POWERED ON BEFORE BOOTING, THE SYSTEM WILL REPORT A CRC TIME OF .1 MILLISECONDS AND THAT THE CRC GENERATOR IS BAD. IF THIS OCCURS, IT WILL BE NECESSARY TO REBOOT THE SYSTEM AFTER THE HARDFILE IS POWERED UP. THE SAME CONDITION WILL OCCUR IF THE INTERFACE CABLE IS NOT PROPERLY CONNECTED TO THE HARDFILE INTERFACE CIRCUIT BOARD AT THE REAR OF THE PC. IN THIS CASE, HOWEVER, A CRC TIME OF 0 MILLISECONDS WILL BE DISPLAYED.\*

After the system has displayed these messages, it will continue booting and finally ask for the date and time.

\* This will only occur under the TALLGRASS 3.XX version. The TALLGRASS 4.XX version will report "Waiting for Winchester Power-Up" for approximately two minutes, after which time it will abort and default to non-modified DOS.

2. Obtain an A> prompt on the display and type the following command:

TGSYS

(then strike the RETURN key)

The program will respond with the message in Figure 2.1 that warns you to exercise care when running the TGSYS program. Strike any key to continue into the program.

TALLGRASS TECHNOLOGIES CORPORATION  
HardFile Configuration Routine  
for the IBM Personal Computer  
version 4:04

Place a PC-DOS boot diskette in drive a :

Consult the IBM DOS manual for instructions  
on creation of boot diskettes.

\* \* C A U T I O N \* \*

Changing the size of the directory,  
allocation unit, or sector size,  
REQUIRES THAT THE HARDFILE BE REFORMATTED.

Consult the user manual on use of the  
Tallgrass 'UTILITY' program for reformatting.

Strike any key when ready.

Figure 2.1 TGSYS Caution Message

2-2A

TALLGRASS Version 3.XX  
Support for IBM PC DOS Version 1.10

**Partitioning the HardFile**

The next display (Figure 2.2) will report the size of the HardFile in use and the maximum number of logical drives permitted. An arrow indicates which parameter or option has been selected for modification. The program only responds to the following keystrokes:

- "+" Adds the storage space of one logical drive (or disk surface) to the storage space of the logical drive pointed to by the arrow. Every time the "+" key is pressed, the storage capacity of another logical drive will be added to the indicated drive until all of the storage capacity of the HardFile is assigned.

"-" Similar in operation to the "+" key except this key causes storage space to be subtracted from the logical drive pointed to by the arrow.

NOTE: "+" AND "-" CAN BE KEYED FROM EITHER THE KEYPAD ON THE RIGHT OR THE TOP ROW OF KEYS.

SPACE BAR Moves the arrow from one logical drive to the next.

"ESC" Pressing the ESCAPE key causes TGSYS to exit the partitioning portion of the program and go on to configuration.

"H" Stands for "HELP". Pressing the "H" key at any time during the execution of the TGSYS Program will display an explanation of the various options and the keystrokes required to change parameters.

NOTE: PRESSING ANY KEY OTHER THAN THOSE DESCRIBED, WILL CAUSE THE PC TO BEEP. THE COMBINATION OF CTRL + C WILL ABORT TGSYS AND RETURN THE DOS A> PROMPT.

The total HardFile capacity of 12.53 mb may be partitioned in increments of 3.13 mb to form logically individual disk drives. Please combine/remove increments as desired to create the desired number and size(s) of logical drive(s).

```
COMMANDS
+ Combine increment
- Remove increment
spacebar Move indicator
`esc` Exit to next screen
H Help

---> 3.13 mb for DRIVE ONE
      3.13 mb for DRIVE TWO
      3.13 mb for DRIVE THREE
      3.13 mb for DRIVE FOUR
```

Figure 2.2 HardFile Partition Display

Take a few moments to experiment with the various combinations. When you have decided on a combination\*, press the ESC key. The system will record the information and display the default HardFile configuration shown in Figure 2.3.

\* It is recommended that a hardcopy (printed or written) be made of the Partition information. If it becomes necessary to setup the HardFile after a system failure, this hardcopy will provide the previous setup information.

### Configuring the HardFile

The configuration portion of TGSYS responds to the the following keystrokes:

SPACE Moves the arrow from one category to another within  
BAR a group.

"," Changes the default parameter to the one desired.

RETURN Causes the arrow to move to the next group.

"ESC" Pressing the ESCAPE key causes TGSYS to record the configuration information in the newly created TGCONFIG.DAT file on the TALLGRASS Boot Diskette. The system will then exit the TGSYS Program and enter the UTILITY Program. The ESC key will only cause this action when the arrow is positioned to "Done". Refer to Figure 2.3.

If this is the first time TGSYS has been run, proceed to Chapter Three, "HardFile Diagnostics" and refer to Section 3-1 for use of the UTILITY program. Upon completion of the checkout procedure outlined, choose the QUIT function and press any key to reboot the system. This allows the new configuration data to be recorded on the HardFile. If this is not the first run, just choose the QUIT function and press any key to reboot.

Described in Sections 2-3 through 2-9 are the various options and parameters which must be set using TGSYS. Of these, "Verify Read After Write", "Cache Memory", "Landing Zone" and "Drive Designations" can be changed from their initial setting by running TGSYS again. The HardFile does not need to be reformatted following any of these changes. However, the changing of "Duplicate Directory Option", "Allocation Unit Size" or "Directory Size" REQUIRES THAT THE HARDFILE BE REFORMATTED IN ORDER TO INSTALL THE REDEFINED DIRECTORY OR DIRECTORIES.

```

OPTIONS:                               Press "h" for Help.
    Verify read-after-write           NO
    Duplicate directory                 NO
    Cache memory                       NO
    Landing Zone                       NO
---> Done press  ESC'

DRIVE ONE
    Designation                        C:
    Allocation unit size                2k
    Directory size                      64

DRIVE TWO
    Designation                        D:
    Allocation unit size                2k
    Directory size                      64

DRIVE THREE
    Designation                        E:
    Allocation unit size                2k
    Directory size                      64

DRIVE FOUR
    Designation                        F:
    Allocation unit size                2k
    Directory size                      64

```

Figure 2.3 HardFile Configuration Display

After the various options and parameters have been set, it is recommended that a hardcopy (printed or written) be made of the Configuration information. If it becomes necessary to setup the HardFile after a system failure, this hardcopy will provide the previous setup information.

2-2B

TALLGRASS Version 4.XX  
Support for IBM PC DOS Version 2.00

The steps to follow when running TGSYS are the same as for TG3.XX/DOS1.10 (see Section 2-2A). The main difference occurs in the storage of the configuration data. TG4.XX/DOS2.00 does not create the file TGCONFIG.DAT, instead the information is stored in an already existing file called TGTBIO.COM.

2-2C

TALLGRASS Version CPM-86 / 3.XX  
Support for IBM CPM-86 Version 1.00

TGSYS for CPM-86 is presently in preliminary form. It is being prepared for final release in the near future.

The HardFile is automatically partitioned into four logical drives with preset allocation units and directory size. In it's present form the only choices to be made are drive designations. After typing TGSYS and a RETURN, the following prompt will appear:

Enter drive designation for FIRST HardFile  
(A,B,C,D,E,F,G,H,I,J,K,L,M,N,O) :

Each time you make a selection, the system will prompt you for the SECOND, THIRD and FOURTH HardFile designations. You must enter all four. When the last designation is entered, the TGSYS program will pause briefly, then display a "Program Complete" message and the A> prompt. At this point TGSYS is complete and the HardFile should be formatted using UTILITY.COMD, similar to UTILITY described in Chapter 3.

2-2D

TALLGRASS Version MS DOS / 3.XX  
Support for T.I. MS-DOS Version 1.25

The steps to follow when running TGSYS are the same as for TG3.XX/DOS1.10 (see Section 2-2A).

2-3

Verify Read After Write

Use of the "Verify Read After Write" option, offered in TGSYS, causes the HardFile to automatically read back the data just written to the disk. This occurs during each write to disk. The data read back is compared to the contents of a 10K RAM buffer which is set aside in the PC. If the comparison fails, the system will rewrite the data up to three times before a DOS error message is returned.

IT IS NOT POSSIBLE TO SELECT THE VERIFY OPTION AND THE CACHE MEMORY OPTION TOGETHER. ANSWERING YES TO ONE CANCELS THE OTHER. NOTE THAT VERIFY MAY BE TURNED ON AND OFF THROUGH THE TGSYS PROGRAM WITHOUT REFORMATTING THE HARD-FILE.

The "Duplicate Directory" option in TGSYS allows the creation and transparent maintenance of a duplicate copy of the regular directory and File Allocation Table (FAT) of each declared drive. This duplicate copy is updated each time the regular directory is updated. The purpose of the duplicate directory is to safeguard the contents of the disk drive in the event of loss or damage to the regular directory. Since the directory/FAT is often the most frequently accessed portion of the drive surface, and because the read/write heads are often positioned over the directory/FAT when the drive is not being accessed, the directory/FAT is especially vulnerable to power loss, hardware failures and software mistakes. The TALLGRASS-supplied COPYDUP command may be executed to restore the directory if one of the following conditions occur:

1. If an abnormal format, or abnormal characters (garbage) appear in the directory.
2. If the DOS CHKDISK command indicates an error
3. If the PC beeps during a directory/FAT access.
4. If the message "File Allocation Table is Bad" occurs.

COPYDUP should not be used casually since it involves possible destruction of recent directory information that might not be present in the duplicate. The duplicate directory may also contain the same errors as the main directory depending on the cause of the error condition.

The "Duplicate Directory" option will significantly slow the effective throughput of the HardFile whenever the directory is being accessed. NOTE: The HardFile must be reformatted if Duplicate Directory is turned off or on after initial formatting; reformatting will erase all stored data in the HardFile.

Use of the "Cache Memory" option causes a 20K area of RAM to be reserved in the PC for use as a disk buffer. This improves file and record access time, in some applications, by reducing the number of disk accesses per file. Its use is best suited for "seek intensive" applications, i.e., those applications that require extensive reading of a particular file, or portion of a file, to the HardFile.

IT IS NOT POSSIBLE TO SELECT THE CACHE MEMORY OPTION AND THE VERIFY OPTION TOGETHER. ANSWERING YES TO ONE CANCELS THE OTHER. CACHE MEMORY MAY BE TURNED ON OR OFF THROUGH THE TGSYS PROGRAM WITHOUT REFORMATTING HARDFILE.



The "Landing Zone" option offers an extra margin of protection against loss or corruption of the directory in those areas that are particularly troubled by power fluctuations.

Use of the "Landing Zone" option causes the read/write heads in the HardFile disk drive to automatically retract after six seconds of inactivity to a track not normally used to store data. The user has the option of turning it on or off, because use of this option may detract from access time performance in some applications.

If the "Landing Zone" option is not enabled, the Landing Zone action can be "manually" accomplished by running the SPEEDTST program and choosing the L option, "MOVE TO LANDING ZONE". This positions the read/write heads so that the HardFile can be safely powered down. Use of this function does not effect the setting of the "Landing Zone" option in TGSYS. NOTE: Landing Zone may be turned on or off through TGSYS program without reformatting HardFile.

Table 2.2 lists the track number used for the landing zone in each TALLGRASS model.

MODEL NO.	TG 3006	TG 3012	TG 3020	TG 3135	TG 3170
LANDING ZONE TRACK # XXX	# 336	# 336	# 522	# 695	# 985

TABLE 2.2

After you have completed setting the various HardFile options, continue configuring by pressing the RETURN key to allow the arrow to be positioned to the first logical drive. Under DOS 1.1, the drive designations may be selected by the user; under DOS 2.0, the drive designations are permanently set as C,D,E, and F, depending on how the HardFile is partitioned, and there is no user input. If you are under DOS 2.0, proceed on to Allocation Unit size.

The various parameters are now selected by pressing the period (.) key repeatedly until the desired selection appears.

TGSYS checks the Disk Drive Switches on the main circuit board of the IBM System Unit to establish how many drives are in the system. This causes the system to default to designations that are not already assigned to the system.

Example:

If you have one floppy disk drive, TGSYS will assume that this drive designation is A:. It also assumes that B: is an imaginary drive. Therefore, TGSYS will cause the first logical HardFile drive to default to C:. Additional drives defined by TGSYS will be assigned remaining designations. TGSYS also checks for the existence of hard disk drive C: in the IBM XT. If it is present, the first logical drive will default to D:.

2-8

Allocation Unit Size

NOTE: SELECT YOUR A.U. SIZES CAREFULLY; CHANGING A.U. SIZES REQUIRES THAT THE HARDFILE BE REFORMATTED.

PC-DOS, MS-DOS, and most typical disk operation systems control the utilization of disk space by maintaining a table, the File Allocation Table (FAT), which describes file areas for the entire disk. In the case of a 320K floppy disk there are so few sectors (640) that each sector may be represented by a separate entry in the FAT. In the case of a 20Mb HardFile, however, there are so many sectors (38,000) and so few FAT entries available (4096 max. 12-bit entries or 6K) that each entry is used to represent a "cluster" of sectors. This cluster size, or Allocation Unit size, is the minimum number of sectors which may be assigned to a file. This will result in wasted disk space when the file or file segment does not fill the Allocation Unit assigned to it in the FAT. Allocation Unit sizes from which you may select are 2K, 4K, 8K, 16K, 32K, and 64K\*.

Pressing the period key (.) with the pointer at Allocation Unit will display these choices in succession as many times as needed.

The optimum Allocation Unit size is usually one that is closest in size to the files being written. For example, if the majority of files written are 14K in size, then an Allocation Unit size of 16K is recommended. Although 2K of space is no longer usable, file access time is improved. If the loss of 2K is undesirable, smaller Allocation Units can be used. If 2K Allocation Units were chosen, seven 2K units will be allocated to form the needed 14K. Since the linked Allocation Units are not necessarily in sequential order on the HardFile, they must be searched for when following the links. This searching increases the file access time thus decreasing system efficiency.

Allocation Unit size also affects FAT size. Small Allocation Units require a larger FAT since there are more Allocation Units to record. Larger Allocation Units result in a smaller FAT. The FAT will consume 1/2K to 6K of main RAM space during each access.

\*Under DOS 2.0, Allocation Unit sizes are limited to 2-32K.

The number of directory entries should be chosen carefully. The number of files to be created must be equal to or less than the number of directory entries. If the directory is too small, there may not be enough entries to handle the files. If the directory is too large, available HardFile space will be reduced i.e., for every 64 directory entries, approximately 2K is consumed by the directory space.

Once directory space is exhausted, it cannot be increased (or decreased) without reformatting that logical drive, which will result in loss of access to the existing files on the particular logical drive.

## NOTES

## Chapter Three

### HardFile Diagnostics

3-1

#### The UTILITY Program

The UTILITY Program is provided as means of formatting and testing the HardFile. UTILITY uses the configuration information that was entered by the user when running the TGSYS program (Chapter 2). UTILITY, when executed, will attempt to find the configuration information in memory and if absent from memory, on the TALLGRASS Boot Diskette. UTILITY is the only means for installing empty directories on the logical disk drives designated by the user when running the TGSYS program.

Striking the "ESC" key at the completion of the TGSYS Program will record the configuration information on the TALLGRASS Boot Diskette and begin executing the UTILITY program (Figure 3.1) automatically. At this time the various UTILITY program features should be used to check the integrity of the HardFile System. The UTILITY program features are defined below in the order in which they should be executed following completion of TGSYS. It should be noted however, that the user may execute the UTILITY program at any time by causing the system to default to the TALLGRASS Boot Diskette and typing the word "UTILITY" followed by a RETURN.

TALLGRASS TECHNOLOGIES CORPORATION

Utility routine for the IBM Personal Computer

12 Mb. Version 4:05

SELECT	W - Write test	*** ERASES ALL INFORMATION ON HARD FILE ***
	R - Read test	Checks ALL Information to see That It Can Be Read
	F - Format/Certify	*** ERASES ALL INFORMATION ON HARD FILE ***
	E - Examine specified track	
	I - Interface test	
	D - Directory re-initialize	
	B - Badtrack display	
	Q - Quit	

Enter your selection:

Figure 3.1 The UTILITY Menu

Each of the following functions (except Q) have a similar display format. Shown in Figure 3.2 is a sample display and a description of each field.

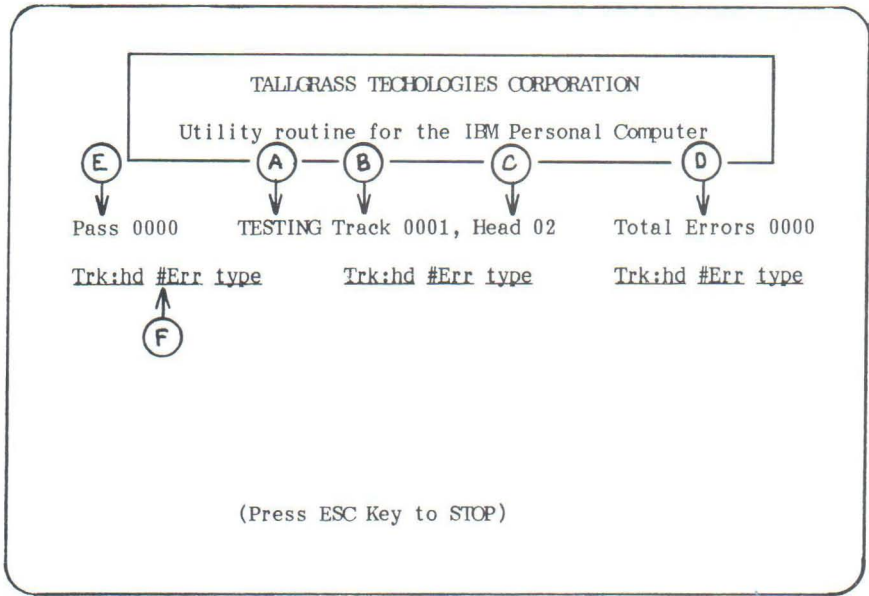

Figure 3.2 Sample Display

In Figure 3.2 :

- A - Name of the operation being performed is displayed.
- B - Track refers to the concentric circles of the platter head on which the operation is performing (analogous to tracks of a diskette).
- C - Head refers to the disk platter surface on which the operation is being performed.
- D - Total Errors refers to the number of errors identified during the operation.
- E - Pass refers to the number of completed exercises over all tracks on the head currently displayed.
- F - The area of the display where errors are listed in the form:

```

Trk:hd  #Err  type
032 00   002   C
    
```

Refer to Table 3.1 for the list of error types.

### Error Types

Type	Description
C	CRC Error
D	Decoder Error
R	Read Error
T	Track Error
W	Write Error

Table 3.1

- I - INTERFACE TEST. The INTERFACE test is used to verify the integrity of the HardFile interface. It exercises the interface logic and performs a read/write test on the buffer within the Hardfile. The interface test does not write or read information from the disk. Should the HardFile fail the INTERFACE TEST, further testing is pointless until the cause of the failure is corrected. The INTERFACE test should run for at least five minutes without any errors. You may exit the Interface Test at any time by striking the ESCAPE key.
- R - READ TEST. The READ test is used to verify the ability of the HardFile to read all disk drive surfaces. This test should be allowed to continue until all tracks and surfaces have been tested. This test is a non-destructive test, i.e., it will not harm the integrity of data stored on the disk surfaces. When running the READ test for the first time after the completion of the TGSYS program, the system should display few if any errors owing to the factory testing and formatting. More than twelve errors during the read test indicates possible damage in shipment. Corrective action will be required to resume HardFile operation.
- F - FORMAT/CERTIFY. This UTILITY feature allows you to FORMAT and CERTIFY the HardFile surfaces. The Utility program formats the HardFile by writing and reading test data to and from the internal disk drive. Each track is exercised thirty-two times. If more than one error occurs, the "BADTRACK" is identified and automatically recorded in the "BADTRACK FILE". Although the HardFile is shipped from the factory already formatted, it is best to re-certify the HardFile prior to actual use. FORMATTING takes about twenty to thirty minutes per HardFile surface. When completed, FORMAT writes a new Directory and FAT.

After each logical drive has been formatted, the system will give the user an opportunity to add BADTRACKS to the BADTRACK FILE. Refer to the BADTRACK MAP STICKER located on the bottom of the HardFile (Figure 3.3). If the FORMAT feature has not identified the BADTRACKS listed on the sticker, these tracks should be entered manually. It will be necessary for the user to be familiar with the logical disk drive to read/write head relationship.

HARDFILE BAD TRACK MAP					
Head	Track	Head	Track	Head	Track
DRIVE SERIAL NO.					

Figure 3.3 BADTRACK MAP STICKER

Up to twenty-four BADTRACKS may be identified by the FORMAT feature. If the FORMAT feature discovers more than twenty-four BADTRACKS, the program will terminate. This condition is usually the result of shipping damage.

- E - EXAMINE SPECIFIED TRACK. This feature allows the user to exercise a specific track for possible weakness or defects. THIS IS A DESTRUCTIVE TEST, I.E., THE EXAMINE TEST WILL DESTROY PREVIOUSLY STORED DATA. The user will usually be warned if an area of the disk is occupied by a file. EXAMINE also provides the user with a means of making entries to the BADTRACK FILE. Any track, good or bad, can be defined as a BADTRACK by using this feature. If examining a track displays an error, the number of errors displayed will be one. Since two errors must occur before a bad track is stored in the BADTRACK FILE, the user should answer "Yes" when the system asks for bad tracks that are not in the display. The indicated BADTRACK should then be typed in for proper recording in the BADTRACK FILE\*.

The following features do not need to be performed following the completion of TGSYS. They can, however, be run whenever needed to perform HardFile diagnostics.



- D - DIRECTORY RE-INITIALIZE. This feature allows the user to to install a blank directory and File Allocation Table. USING THIS OPTION WILL DESTROY THE CURRENT DIRECTORY. To re-install a copy of the current directory use the COPYDUP program discussed in Chapter 2. After the directory has been installed, the system will ask for entries to the BADTRACK FILE. The user may at this time type in other BADTRACKS in much the same way as the EXAMINE feature.
- W - WRITE TEST. The WRITE test is primarily useful as a quick test for the HardFile. It works the same way as the READ test except that test data is written to the disk. THIS TEST DESTROYS DATA PREVIOUSLY WRITTEN TO THE HARDFILE. The WRITE test also writes a blank Directory and FAT upon termination.
- B - BADTRACK DISPLAY. Using this feature allows the user to examine the contents of the BADTRACK FILE for the specified logical drive.
- Q - QUIT. Exits the UTILITY program and causes the system to re-boot.

\* It is recommended that a hardcopy (printed or written) be made of the BADTRACK FILE information. If it becomes necessary to rebuild the BADTRACK FILE, this hardcopy will provide the previous BADTRACK information.

### 3-2 The SPEEDTST Program

When the HardFile is activated by booting the Personal Computer with the TALLGRASS Boot Diskette, the system performs a diagnostic sequence to check the motor speed and the CRC time. The SPEEDTST program allows checking the motor speed and CRC time while at DOS level. Simply default to A> (or the floppy disk drive that contains the TALLGRASS Boot Diskette) and type:

SPEEDTST

(then strike the RETURN key)

The system will display a menu (Figure 3.4) with the following features:

- M - Causes the system to check the motor speed of the disk drive within the HardFile.

- C - Checks the CRC time. The time should be in the range of 11.45 to 13.98 milliseconds.
- L - Moves the read/write head to the Landing Zone. Refer to Table 2.2 in Chapter 2 to determine the track number of the Landing Zone in the particular TALLGRASS model in use. It is suggested that you land the heads before powering off the HardFile.
- Q - Exits the SPEEDTST program and reboots the system.

TALLGRASS TECHNOLOGIES CORPORATION  
 Speed Test Routine  
 for the IBM Personal Computer  
 12 meg version 4:04

SELECT    M - MOTOR SPEED  
           C - CRC TEST  
           L - MOVE TO LANDING ZONE  
           Q - QUIT

Enter you selection:

Figure 3.4 The SPEEDTST Menu

When using the M feature, the following display results:

CURRENT BASE = XXXX    LAST GOOD = XXXX    LAST HANG = XXXX

where:

CURRENT BASE is an indication of the current motor speed. This value will change as the program tracks minor variations in motor speed. The value displayed should be in the range of D620 - D658.

LAST GOOD indicates a value in the range of D620 - D658. This value should not change in the display.

LAST HANG indicates a value in the range of D620 - D658. This value should not change in the display.

A value outside of the given ranges usually means that a problem has developed in the electronic tachometer circuit of the hard disk. Contact your service representative to determine if a hardware malfunction has occurred and what corrective action is required.

## NOTES

## Chapter 4

### Backing Up On Tape

#### 4-1 Why Use a Tape Drive?

As you become accustomed to using your TALLGRASS HardFile System, a false sense of security may develop. With such a large amount of storage capability available and the speed and ease with which it can be accessed, the need for a tape drive may, at first, not be apparent. Why use such a relatively slow mass storage memory device when the HardFile System is so well suited for the task? The fact is, no device is faultless, nor is it immune to failure. A wise computer operator once said, "If it's worth keying-in, it's worth backing-up". This is the primary purpose for the tape drive, backing up the HardFile System as well as the resident system drives. This is made possible thru the use of the TALLGRASS provided routines; TAPE, TGTAPE, TGBACKUP, TGRESTOP and TAPEDIR, all of which are explained in detail within this chapter.

#### 4-2 The Tape Cartridge

Before continuing, a tape cartridge (Scotch\* Brand DC Series or equivalent, see Section 4-4) will be required to perform the various tests.

NOTE: THE TAPE CARTRIDGE, ALTHOUGH WELL CONSTRUCTED, IS QUITE DELICATE AND SUBJECT TO HANDLING AND STORAGE REQUIREMENTS. IT IS STRONGLY RECOMMENDED THAT YOU FAMILIARIZE YOURSELF WITH SECTION 4-4, "TAPE DRIVE & TAPE CARE" AT THIS TIME.

\* Scotch is a registered trademark of Minnesota Mining and Manufacturing Co. (3M).

#### Write Protecting the Tape Cartridge

The tape cartridge is equipped with a write protection mechanism designed to reduce the possibility of accidentally destroying data by over-writing it with new data or by erasing it. TALLGRASS Software carefully observes this feature by requiring that the tape be "SAFE PROTECTED" to be read from (as in an UNSAVE operation) and, conversely, not "SAFE PROTECTED" prior to writing to it (Figure 4.1).

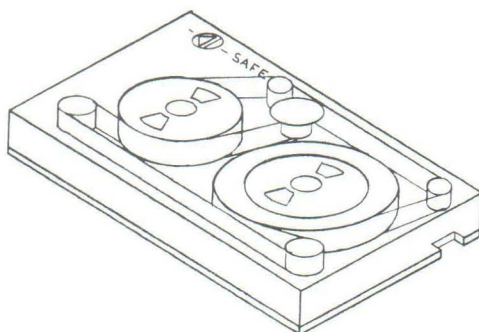

"Safe Button"



- SAFE

"NOT SAFE PROTECTED"  
i.e. can be read from  
and written to.



- SAFE

"SAFE PROTECTED"  
i.e. can be read  
from ONLY.

The position of the "Safe Button" can be changed by using a small regular blade screwdriver or similar instrument (thin coin). Simply insert the screwdriver into the slot and rotate it 180 degrees (in either direction) until it snaps into position.

Figure 4.1 Tape Cartridge Detail

4-3

The Tape Drive

As with the Tape Cartridge, the Tape Drive is a delicate instrument and should be treated accordingly. Please take a moment to familiarize yourself with Section 4-4 if you haven't already done so.

Insertion and Removal of the Tape Cartridge

1. The tape cartridge slides into the tape drive by means of grooved tracks on either side of the tape drive in the cabinet tape slot. The aluminum base of the cartridge forms ridges on the bottom edge which slide into the grooves on either side of the tape slot in the tape drive. A tape cartridge should be inserted now to allow further testing.

2. A spring-loaded door on the right front of the tape cartridge swings open inside the slot as the cartridge slides into the grooves. Little resistance will be encountered as the tape is inserted the first inch into the slot. At that point, resistance will be felt as the holding latch comes into contact with the cartridge. Even pressure on both sides of the cartridge will result in the final seating and securing of the cartridge in the tape drive. The cartridge will then snap into position.

When the cartridge is properly inserted, it should be secure and held captive by the spring latch. Removal of the cartridge will require a moderate pull sufficient to overcome the spring latch. DO NOT remove the cartridge from the tape drive while the tape is in motion.

#### 4-4 Tape Drive & Tape Care

The reliability of a device is only as good as the care with which it is treated. If you contaminate the gasoline for your car with water, it soon fails. If you do not clean the windshield, it becomes impossible to see through. If you expose the oil to extreme temperatures, it soon breaks down. So it goes with tape drives. The tape media must never be touched, the drive must be kept clean and the operating temperature range always adhered to. Presented here is a set of guidelines which, when followed, will insure high reliability and long life for your tapes, drive and precious data they contain.

#### Tape Cartridge Handling, Preparation and Storage

##### Handling:

- NEVER -touch the recording media in any way.
- NEVER -manually advance the tape from one hub to the other.
- NEVER -place objects on the tape cartridge.
- NEVER -remove the cartridge from the drive while the tape is in motion.
- NEVER -expose the tape cartridge to extreme temperatures.

## Preparation:

New tapes should be-

- conditioned prior to use. Expose the tape to the operating environment for a time equal to or greater than the time away (up to maximum of eight hours).
- Fast forwarded and Rewinded to repack the tape within the cartridge (CERTIFY does this automatically).
- certified by running CERTIFY.

## Storage:

Tapes should always be-

- kept in their protective case and stored in a cool dry place.
- operated under the following conditions:
  - Temperature: 41 to 113 F (5 to 45 C)
  - Relative Humidity: 20 to 80% noncondensing
  - Maximum Wet Bulb Temp.: 79 F (26 C)
- kept away from stray magnetic fields i.e., motors, power transformers, magnetic tools, telephones, CRT monitors, etc.
- advanced to Beginning of Tape (BOT) or End of Tape (EOT) before removal.

Remember, the tape cartridge, like all contact recording media, has a useful life span and will wear out. Excessive errors or abnormal audible noise may indicate a worn out cartridge or an impending failure. Data on that cartridge should be replicated on a new cartridge as soon as possible.

## Tape Tension

Proper tape tension is necessary for successful read/write operation. It is recommended that a cartridge be retensioned (by Fast forwarding and Rewinding) prior to use if any of the following conditions apply:



1. Prolonged storage time
2. Storage at a temperature extreme
3. Physical shock
4. Excessive read/write errors

### Tape Drive Cleaning

The read/write head assembly and integral tape cleaner should be cleaned after the first two hours of tape movement when using a new tape cartridge. Normal cleaning should be done after every eight hours of tape movement. Clean these areas with a lintless cotton swab moistened with an IBM (or equivalent) head cleaning solution or isopropyl alcohol if it is not available. Care should be taken to ensure that excess cleaner is not applied and that all residue is removed. Head cleaning should be performed with the power off (Figure 4.2).

The sensor within the opening of the Tape Drive that senses the Beginning of Tape and the End of Tape should be dusted off occasionally using a dry cotton swab. See Figure 4.2 for the location of the sensor.

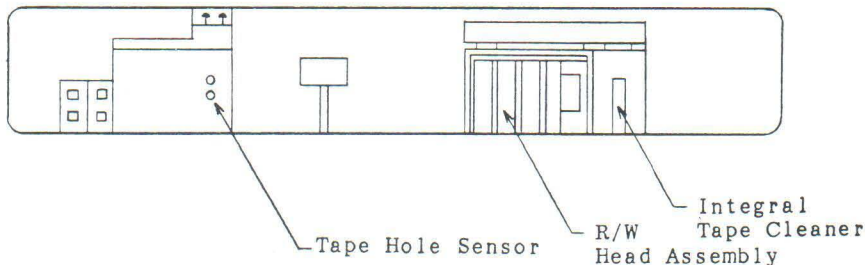

Figure 4.2 Cleaning Locations

#### Recommended Tape Cartridges

3M/Scotch Brand : Use the DC-300XL to store up to 12Mb  
 Use the DC-600A to store up to 45Mb  
 (for the TG-3135/70 only)

Archive Corp. : Use the Model 09C to store up to 12Mb

When backing-up and restoring data using the Tape System, a decision should be made between Streaming Tape or File-By-File methods. To backup an entire logical HardFile drive, that is, ALL the files on that drive, the SAVE feature in the TAPE Program (Section 4-6) should be used. When using SAVE to backup, the UNSAVE feature (also in the TAPE Program) must be used to recover the files from the tape. Individual file recovery is not possible when backup was accomplished using SAVE.

The File-By-File method allows individual files (or groups of files by using global characters) to be backed-up (TGBACKUP, Section 4-8) or restored (TGRESTOR, Section 4-9) using the Tape System. If it is desired to backup all the files of a particular logical drive (HardFile or Floppy) and later recover them individually, use the \*.\* global file designation. In this way, individual files can be restored from the tape to any logical drive (HardFile or Floppy) in the system. The File-By-File method makes it possible to backup to tape, files from one HardFile System and restore them to another HardFile System. This is accomplished by backing-up with TGBACKUP, removing the tape and replacing it in the new System, and then restoring using TGRESTOR. TAPEDIR (Section 4-10) is provided to read the directory of a tape track which was created using TGBACKUP.

Prior to running TAPE, TGTAPE, TGBACKUP, TGRESTOR or TAPEDIR, the computer must be booted up on a TALLGRASS Boot Diskette as discussed in Chapter Two, "Software Installation".

Operation of the Tape Cartridge System should be checked out following receipt of your new HardFile System. Insert a prepared tape cartridge (Section 4-4) into the slot. Executing the TAPE program will result in the menu shown in Figure 4.3.

TALLGRASS TECHNOLOGIES CORPORATION

Cartridge Tape Backup Facility IBM Personal Computer

12 meg Version 4:06

SELECT      R - Rewind the tape  
              F - Fast forward  
              S - Save disk to tape  
              U - Unsave tape to disk  
              V - Verify tape can be read  
              E - Erase tape  
              C - Certify tape  
              Q - Quit

Enter your selection:

Figure 4.3    The TAPE Menu

#### The CERTIFY Feature

CERTIFY is an extensive test of the tape drive, tape cartridge, controller and interface electronics. It is also a DESTRUCTIVE exercise i.e., it writes and reads its own test data to and from the tape. It is important, therefore, that the tape does not contain vital data as it will be lost.

Select C for Certify tape. During the Certify exercise, each action being performed will be listed on the lower, left-hand corner of the screen. Also, during any tape motion, the screen will display position, error and other informational codes (Table 4.1). If any errors are detected by CERTIFY, a listing will appear at the end of the pass. More than one error per tape track is unacceptable. If this is the case, try a new tape. Cleaning the tape drive will sometimes help.

The Certify exercise takes about ten or twenty minutes to complete one full pass depending upon the drive capacity. CERTIFY will continue to run indefinitely until interrupted by depressing the "ESC" key. One pass of CERTIFY is usually sufficient to insure the integrity of the Tape System.

POSITION CODES DURING TAPE MOTION

BOT	Beginning of Tape
EOT	End of Tape
WZ	Warning Zone (tape leader)
RZ	Recording Zone
.	Normal record
-	Wrong Record/Missing Record
W	Missing Records (unrecorded tape)
T	Disk Seek ERROR
*	CRC ERROR Reading Tape
D	Decoding ERROR Reading Disk
@	Dummy Record used in lieu of a BADTRACK on the Disk Drive

Table 4.1

Always advance the tape to either BOT (by Rewinding) or EOT (by Fast forwarding) following completion of a tape session. Power failure, surges, etc., may cause undefined tape drive action which can result in the destruction of data. While at the BOT or EOT, the tape is in a region where data is not written and is therefore safe. The tape cartridge can be safely removed from the drive at any time that BOT or EOT is displayed and tape motion has ceased.

CERTIFYING

TAPE TRACK --0  
 PASS 00  
 WRITING  
 TOTAL ERRORS 0000

. WZ RZ .....  
 .....  
 .....  
 .....  
 ..... WZ EOT

FAST FORWARD EOT

Figure 4.4 Typical display during CERTIFY

## Other Features

In addition to CERTIFY, the TAPE Program provides other features for tape operation which are described here.

### REWIND and FAST FORWARD

These features are similar to those found on common home cassette decks with one important difference: once initiated, they will run to completion with no provision to stop them. Each takes roughly one minute to complete.

### To SAVE or UNSAVE...

The features SAVE and UNSAVE provide you with the capability of backing-up (SAVE) the contents of a HardFile logical drive to tape and restoring (UNSAVE) the saved data back to the HardFile.

In Chapter Two, "Software Installation", use of the TGSYS Program was described in much detail. It explained how to partition the HardFile into different logical drive configurations. There is a direct correlation between the HardFile configuration and the use of SAVE/UNSAVE. It is important to realize that SAVE and UNSAVE operate on the ENTIRE logical drive. That is, an image of the data recorded on the logical drive is written to tape, including the BADTRACK File (Chapter 3), the Directory and the File Allocation Table. For this reason, tapes made on one HardFile System cannot be unsaved to another HardFile unless the Drive Configuration and BADTRACK File are identical. ALL the files of the particular logical drive chosen are saved or unsaved. Individual files cannot be manipulated with SAVE and UNSAVE. If individual file access is required, the commands TGBACKUP and TGRESTOR (Sections 4-8 & 4-9) should be used instead.

Listed in Table 4.2 are aspects of some different configurations. Although Table 4.2 depicts a "12 + 12Mb" system, the principle remains the same for other systems.

Possible Configurations for a " 12 + 12Mb " System

NUMBER OF LOGICAL DRIVE(S)	DESIGNATED	OF SIZES	then	will occupy	TAPE TRACK(S)
1	C:	4/4	C:		4
2	C: D:	2/4 2/4	C: D:		2 2
4	C: D: E: F:	1/4 1/4 1/4 1/4	C: D: E: F:		1 1 1 1
3	C: D: E:	1/4 1/4 2/4	C: D: E:		1 1 2
2	C: D:	1/4 3/4	C: D:		1 3

NOTE: The drive designations shown here are only examples; actual designations will depend on your system. If there is one resident system drive (A:) then C: through F: will be available. If two (A: B:) then C: through F:, if three (A: B: C:) then D: through G:. These examples are typical cases, many more arrangements are possible.

Table 4.2

For a " 12 + 12Mb " system, one tape is sufficient to SAVE the entire contents of the HardFile. For " 12 + 20Mb " (or larger) systems, two or more tapes will be needed if the entire disk is to be saved. In the latter case, the system will prompt you when another tape is needed to complete the backup.

You can see that the number of tracks needed holds the key to the number of copies possible. In other words, if only one track is required, then up to four copies of that logical drive can be made on a single tape. If two tracks are required, then two copies can be made. Of course, if more than two tracks are required, then only one copy is possible. For larger systems, " 12 + 20Mb " and above, this relationship is not as simple. If the HardFile is divided into four drives, a single drive (20Mb / 4 = 5Mb) will necessarily occupy more than one tape track (12Mb / 4 = 3Mb).

## The SAVE Feature

Select S for SAVE. The following prompts will appear:

Which Drive? C, D, E, F

- Which drive do you want to SAVE. This appears only if the HardFile is configured as more than one drive.

ENTER NUMBER OF TAPE TRACK TO USE 0,1,2,3

- Which tape track to start saving to. For a blank tape, select 0 for the most efficient use of the tape.

BACKUP NUMBER =

- This appears in the TAPE RECORD ORIGIN REPORT to help keep track of different tapes. This can be any number you choose (up to four digits).

BACKUP NAME =

- Can be any eight character string. The tape name will also appear in the origin report as above.

NOTE: THESE ARE ONLY EXAMPLES, THE DRIVE DESIGNATIONS AND TAPE TRACK NUMBERS DEPEND ON THE SYSTEM YOU ARE USING AND ITS CONFIGURATION. THE TAPE TRACK NUMBERS 0-9 WILL BE LISTED FOR LARGER TAPE DRIVES.

In order to SAVE to a tape track, it must be blank (erased) and not SAFE PROTECTED. Before the TAPE Program begins writing data to the tape, it will first read a small portion of the tape to determine if it has been erased. If either of these conditions are not satisfied, an error message will occur advising you of the pending condition.

After the information is saved, it will automatically be verified. The position codes that appear have the same meaning as in CERTIFY (Figure 4.4). If during verification, an error has occurred, the system will reinitiate the VERIFY up to three times in an effort to obtain proper verification. If the final effort to verify is unsuccessful, verification is terminated and the following message(s) will be displayed:

HEAD XX TRACK XXXX NOT SAVED ON TAPE

Press any key to continue. The HEAD/TRACK numbers will be correlated to their respective files and the following message(s) will be displayed:

```
filename      THIS FILE IN DANGER
```

Make a list of these HEAD/TRACK numbers and endangered files. Erase the tape and attempt the SAVE again. If these same HEAD/TRACK and filenames reappear, this indicates the files are damaged and cannot be saved. These files are no longer usable.

These HardFile HEAD/TRACK numbers should be tested using the READ test and if found faulty, examined using EXAMINE (both found in UTILITY, Section 3-1) and entered into the BADTRACK file if necessary.

#### The UNSAVE Feature

Select U for UNSAVE. The following prompts will appear:

```
Which Drive? C, D, E, F
```

- As in SAVE.

```
ENTER NUMBER OF TAPE TRACK TO USE 0,1,2,3
```

- As in SAVE.

NOTE: THESE ARE ONLY EXAMPLES, THE DRIVE DESIGNATIONS AND TAPE TRACK NUMBERS DEPEND ON THE SYSTEM YOU ARE USING AND ITS CONFIGURATION. THE TAPE TRACK NUMBERS 0-9 WILL BE LISTED FOR LARGER TAPE DRIVES.

An origin report follows this (Figure 4.5) showing important information about the tape.

```
UNSAVING TAPE TO DISK
```

```
DRIVE ----- D:  
HEAD ----- 0  
TAPE TRACK --- 0
```

```
TAPE RECORD ORIGIN REPORT :
```

```
Tape track ----- 0  
Tape number ----- 00001  
Tape name ----- test  
Creation date ----- 06-11-83  
Creation time ----- 10:30:33  
Saved from drive ---- C:  
1st records's # ---- 000
```

Figure 4.5 Tape Origin Report



If a BADTRACK File exists, it will be listed and you will be questioned by the system if you still want to UNSAVE. If the tape to be unsaved was initially saved from the same HardFile with the same BADTRACK file, the data will be unsaved intact. If this is not the case, the data may be damaged when unsaved. You will also be prompted if the origin reports differ (Figure 4.6).

If any errors occur during UNSAVE, the system will automatically attempt another UNSAVE. After the third unsuccessful attempt, the program will abort and list an error report.

#### UNSAVING TAPE TO DISK

```
DRIVE ----- D:
HEAD ----- 0
TAPE TRACK --- 0
```

#### TAPE RECORD ORIGIN REPORT :

```
Tape track ----- 0
Tape number ----- 00001
Tape name ----- test
Creation date ----- 06-11-83
Creation time ----- 10:30:33
Saved from drive ---- C:
1st records's # ---- 000
```

Tape track 0 Has Records That Were Saved from Drive C:.  
Are you sure you want to UNSAVE to Drive D:? (Y/N) :

Figure 4.6 Origin Report Error

### The VERIFY Feature

VERIFY, unlike CERTIFY, is a non-destructive test that checks the current tape data for readability without modifying it. This test detects and displays errors using the same format as CERTIFY (Figure 4.4 and Table 4.1). The cartridge must be SAFE PROTECTED to run VERIFY.

### The ERASE Feature

ERASE is a FULL-WIDTH ERASE over ALL tracks. This erases the entire tape at once. No selective track erasure is available. As with Rewind and Fast forward, ERASE, once initiated, cannot be stopped. Consequently, think twice before Erasing. The cartridge must not be SAFE PROTECTED. ERASE takes two minutes.

## Exiting The TAPE Program

QUIT exits TAPE and returns control to the current operating system in use.

### Use of "ESC"

The "ESC" key will return the user to the menu or to a different level of the program depending upon which point in the program it is used. Since some features (Rewind, Fast forward & Erase) are non-interruptable, there may be no immediate response to the "ESC" key. These features will run to completion before "ESC" is recognized and tape motion stops.

## The UNFTAPE Program

The TAPE Program can only operate under the DOS for which it was designed. "UNFTAPE" is provided as a basic HardFile-to-Tape Backup System alternative. UNFTAPE is unformatted and makes no attempt to consult a file directory or to understand drive designations. The user is prompted to decide which surface to save to which track. UNFTAPE has no recovery capability other than disk platter to tape track. UNFTAPE should NOT be used by PC-DOS or CPM-86 users. It is intended for use with other operating systems that may lack support for the TALLGRASS tape devices.

4-7

## The TGTAPE Program

The TGTAPE Program, which requires at least 128K of RAM and operates under PC DOS 2.0, is very similar to the TAPE Program. Those features common to both; Rewind, Fast forward, Verify, Erase, Certify and Quit, operate in the same manner as with TAPE. TGTAPE, however, does not support the SAVE and UNSAVE features. Instead, refer to Sections 4-8 and 4-9 on the use of TGBACKUP and TGRESTORE (both also require 128K and PC DOS 2.0) which provide for individual file manipulation.

## The Interface Test

The tape Interface Test operates much the same as the UTILITY Interface Test. That is, it tests all the interface logic to the tape drive just short of putting the drive into motion. It will run until interrupted by "ESC" (Figure 4.7). All position codes have the same meaning as in Table 4.1.

TESTING INTERFACE

TAPE TRACK -- 0

.....  
.....  
.....  
.....

Figure 4.7 Tape Interface Test

4-8

TGBACKUP

TGBACKUP provides you with the means to backup a particular file or files from any disk drive, hard or floppy, to the tape. TGBACKUP follows much the same format as the PC DOS 2.0 "BACKUP" (Fixed Disk) Command. The format for TGBACKUP is:

TGBACKUP [d:][path]filename.ext /Tn [/S][/M][/D:mm-dd-yy]

where:        [] -indicates an optional parameter  
              d: -is the logical Source Drive  
              n -is the Destination Tape Track  
                  number (0-3, 12/20Mb & 0-8,  
                  35Mb and above)  
              /S /M /D -operate as in PC DOS (see your  
                  manual)

NOTE:         /A -add (Append) is not supported by  
              TGBACKUP  
              \* , ? -global characters are allowed

The filenames being backed-up to tape will appear on the display before they are transferred (copied) to tape.

The message "Track n has been loaded." signifies the completion of the backup operation and shortly thereafter control returns to DOS.

TGBACKUP should be used wisely. Once information is backed-up to a particular Tape Track, additional files cannot be backed-up to it. In this way, file overwrite protection is preserved. If an attempt is made to backup to an already occupied Tape Track, the following response will appear:

Tape needs to be erased

Before Erasing, remember, the Erase feature erases the ENTIRE tape.

If the quantity of data being backed-up is too large to fit on a single tape track, the overflow data will be automatically backed-up onto the next track. It should be noted that the next track is now occupied, therefore, it cannot be used for further backup.

See Table 4.3 for the list of error messages.

#### TGBACKUP and TGRESTOR Error Messages

Bad Track Number  
Out of Tape (insufficient space  
on track for makeup records)  
No more records on Tape  
Bad Read  
Write Error (cartridge may be  
"SAFE PROTECTED")  
Tape needs to be erased  
No records on Tape (blank tape)

Table 4.3

4-9

#### TGRESTOR

TGRESTOR is used to retrieve files from tape, that were put there with TGBACKUP. TGRESTOR follows much the same format as the PC DOS 2.0 "RESTORE" (Fixed Disk) Command. The format for TGRESTOR is:

```
TGRESTOR [d:][path]filename.ext /Tn [/S][D]
```

where:     [] -indicates an optional parameter  
d: -is the logical Destination drive  
n -is the Source tape track number  
      (0-3, 12/20Mb & 0-8, 35Mb and above)  
/S /D -operates as in PC DOS (see your  
      manual)  
\*,? -global characters are allowed

The filenames being restored to the disk will appear on the display AFTER each transfer is complete. The following message will appear at the beginning of the transfer:

```
*** Restoring files form tape track n ***
```

TGRESTOR can be used to restore the files from a tape to any drive (HardFile or Floppy) desired, regardless of where they were initially backed-up.

See Table 4.3 for the list of error messages.

4-10

#### TAPEDIR

To obtain a directory of a tape track:

```
TAPEDIR [path][filename.ext]/Tn[/S]
```

where: [] -indicates an optional parameter  
n -is the tape track number  
/S -operates as in PC DOS (see your manual)  
\*,? -global characters are allowed

## NOTES

Chapter Five

Having Trouble?

5-1 HardFile System Trouble Chart

HardFile Power On Sequence Using IBM PC-DOS

Key:

→ No (unsuccessful operation)  
↓ Yes (successful operation)

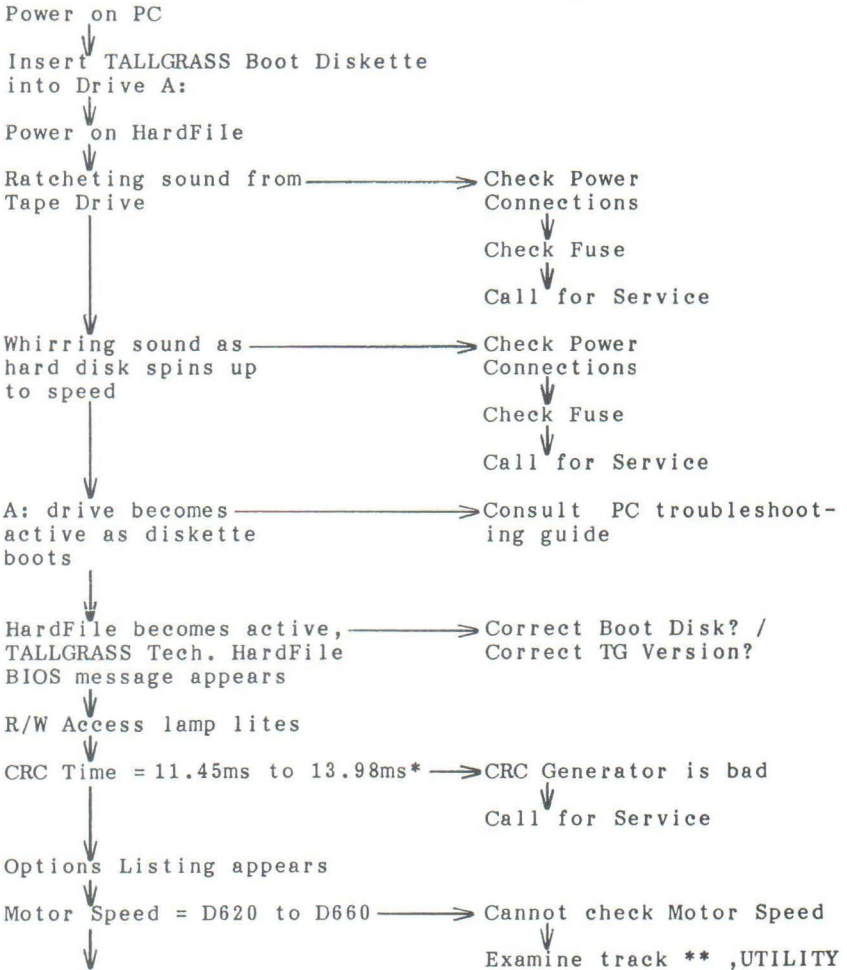

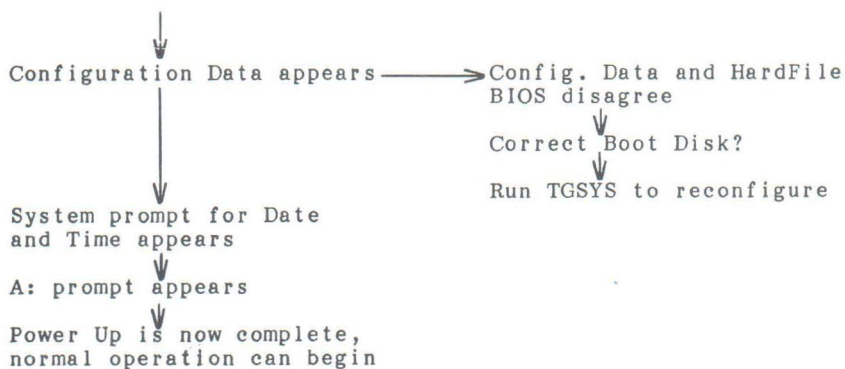

For any further problems, consult the Sections concerning the use of the UTILITY and TAPE programs.

\* TI MS-DOS ranges 12.47ms to 14.11ms  
COMPAQ DOS ranges 12.75ms to 13.16ms  
Columbia ranges 11.18ms to 12.75ms

\*\* TG 3006, #0132H ; TG 3012, #0132H ; TG 3020, #01E0H  
TG 3135, #02B8H ; TG 3170, #03DAH



Because it is sometimes impractical to display error messages on the screen the TALLGRASS BIOS communicates with the operator by using a series of coded beeps that emanate from the PC when certain error conditions occur. The beeps are patterned to correspond to binary representations of numbered error codes. Table 5.1 shows the pattern and meaning of these codes.

Error Code	Sound Pattern	Error Condition
1	SSSL	CRC Generator Timeout. The CRC calculation did not occur within the predetermined amount of time.
2	SSLS	Read Timeout. A Read operation was initiated but a valid preamble was not detected.
3	SSSL	DMA Timeout. A DMA transfer was initiated but was unsuccessful.
4	SLSS	Head Stepping Error. A R/W head position command was issued but was unsuccessful.
5	SLSL	Head Homing Error. A command was given to position the R/W head to track 00 and was unsuccessful.

KEY:     S = Short beep                   L = Long beep

Table 5.1

Since the HardFile appears to DOS as just another disk drive(s), all DOS error messages apply. Consult the "Device Error Messages" and "Other Messages" sections of your DOS manual for more information.

Some error messages can be especially confusing depending upon when they occur. "Divide Overflow", for example, may occur during a HardFile directory or file access. This usually indicates damage to the Directory/FAT. Re-Initialization of the directory may be required (Section 3-1) or the DOS "RECOVER" Command might be attempted to repair the damaged directory.

TALLGRASS Technologies maintains a staff of specialists in the Customer Service Department to help with any problems that arise in the operation of your HardFile Subsystem. The Technical Support Specialists can usually diagnose your problem over the telephone and make recommendations on how to obtain best HardFile performance. This troubleshooting service is also available outside of the U.S. via telex.

When calling for assistance on the telephone, if possible, move the telephone near to your computer system. This will allow you to issue test commands to your system in order to determine the source of the problem.

Below is a suggested list of items to have on hand to expedite the troubleshooting process.

1. The model and serial numbers of your HardFile.
2. The version number of the TALLGRASS Software you are using. This number can be found on the label of the diskette that was sent with the unit. The version number on the screen may not correspond with the release version number printed on the diskette.
3. The type and version number of the Operating System and Application Software you are using.
4. A list of options or other peripherals currently in use with your system.

Many types of software and software packages are available on the market today. Understandably, not all are compatible with each another. If you experience problems using the HardFile with different software packages, consult the Sections on DMA operation and I/O addresses (7-1 & 7-2). Some programs make use of the Interrupt System and/or DMA which can create conflicts between the program and the HardFile.

TALLGRASS' software modifies the BIOS portion of the O/S so that it can recognize the HardFile. Any application software that also modifies BIOS may create system conflicts. If still in doubt, contact the software supplier your Authorized TALLGRASS Dealer.

## Chapter Six

### Maintenance

6-1

### Replacement Parts

#### Parts List for the TG-3000/3100 Series

##### CABINET PARTS AND HARDWARE

TALLGRASS P/N	Description
0-64-1064-1206	Front panel inlay, TG-3006
0-64-1064-1212	Front panel inlay, TG-3012
0-64-1064-1220	Front panel inlay, TG-3020
0-64-1064-4535	Front panel inlay, TG-3135
0-64-1064-4570	Front panel inlay, TG-3170
1-75-1035-1000	Top cover series, TG-3000/3100
1-75-1035-1200	Bottom chassis series, TG-3000/3100
1-76-1035-1202	Heatsink, regulated power supply
1-76-1035-1301	Left "T" controller support bracket
1-76-1035-1302	Right "T" controller support bracket
8-98-2031-0630	Replacement hardware package*

\*The replacement hardware package contains:

- 6 ea. Machine screw, 6-32 x 1/4"
- 3 ea. Tape drive mounting spacer, 3/8" dia.
- 6 ea. #6 flat washer
- 6 ea. #6 internal tooth lock washer
- 6 ea. Hex machine nut, 6-32 x 5/16"
- 3 ea. Fuse, MDL 3/4 amp. slow blow

##### POWER SUPPLY ASSEMBLIES

TALLGRASS P/N	Description
8-96-1999-3000	Backpanel regulated power supply assembly and transformer for TG-3000 series*
8-99-1071-9000	Switching power supply for units equipped without regulated power supply assemblies.
8-99-1099-0014	Regulated power supply Disk +5/12 Volts
8-99-1999-0014	Regulated power supply Tape +5/24 Volts

\*Part number 8-96-1999-3000 backpanel regulated power supply consists of part numbers 8-99-1999-0014 and 8-99-1099-0014 regulated power supplies, fuse holder, power switch, power transformer (wired for U.S. power), and the line cord. Note that part numbers 8-99-1999-0014 and 8-99-1099-0014 may be purchased separately.

## CABLE ASSEMBLIES

TALLGRASS P/N	Description
1-27-2025-0934	Ribbon cable assembly, disk to controller, 34 conductor (9 inch)
1-27-2025-1220	Ribbon cable assembly, disk to controller, 20 conductor (12 inch)
1-27-2025-1350	Ribbon cable assembly, tape to controller, 50 conductor (13 inch)
1-27-2025-3634	Ribbon cable assembly, controller to DMA interface circuit board, 34 conductor (36 inch)

## MAJOR SUB-ASSEMBLIES

TALLGRASS P/N	Description
0-77-1023-2006	6.25 Mb Disk Drive Miniscribe Model 2006
0-77-1023-2012	12 Mb Disk Drive Miniscribe Model 2012
0-77-1023-4020	20 Mb Disk Drive Miniscribe Model 4020
0-77-1069-9415	35 Mb Disk Drive CDC MODEL 9415-5
0-77-????-????	70 Mb Disk Drive Vertex Model ????
0-78-1039-9020	Tape Drive TG-3000 series Archive Model 9020B
0-78-1039-9045	Tape Drive TG-3100 series Archive Model 9045B
8-99-1999-0011	Analog Circuit Board
8-99-1999-0012	Buffer Circuit Board
8-99-1999-0013	DMA Interface Circuit Board

## ACCESSORIES

TALLGRASS P/N	Description
0-65-1064-0250	"Wired For 250 VAC" Sticker (pkg. of 6 ea.)
0-65-1064-2181	Bad Track Map Stickers
8-88-1035-0007	Beige Front Panel Touch-Up Paint
8-88-1035-0008	Gray Cabinet Touch-Up Paint
8-90-2033-3000	Shipping Container TG-3000/3100 series
8-93-2060-3006	Service Manual TG-3000 series
8-93-2060-3135	Service Manual TG-3100 series
8-93-2060-5000	Spare Parts Order Form

## Chapter Seven

### Programming Notes

#### 7-1

#### DMA Operation

The standard TG-09 IBM Interface Kit contains an Interface Circuit Board which uses Interrupt 3 and DMA Channel 3. While the interrupt is strappable to different interrupt lines, the DMA Channel is fixed on Channel 3. The DMA circuitry of the Interface Circuit Board is designed to work in conjunction with the 8237 DMA Controller located on the system board. Beginning with Revision H, the Interface Circuit Board is capable of sharing Channel 3 by virtue of a tri-state driver which is placed in the high-impedance state when the DMA circuits are disabled.

Relatively few accessories, IBM and others, use DMA at all. The IBM fixed disk uses DMA Channel 3. Both the IBM and TALLGRASS hardware/software are designed to share DMA Channel 3 in a serially re-usable manner. Single-user O/S such as IBM DOS 2.0 will see no difficulty in sharing DMA Channel 3. Multi-user and/or multi-tasking systems will require special programming considerations to avoid competition for DMA. Users of O/S other than IBM PC DOS may contact TALLGRASS for further information.

#### 7-2

#### I/O Addresses 280H - 285H

Six I/O addresses are decoded to provide the control lines required by the TALLGRASS controller. Address lines A0 thru A9 are decoded to recognize I/O ports 280H thru 285H. Secondary responses will occur at ports 680H - 685H, 0A80H - 0A85H and 0E80H - 0E85H. Solder straps allow decoding of these different addresses, however, no software patch is presently available. When used with the TALLGRASS controller, the I/O ports are assigned functions as defined in Table 7.1.

#### I/O Port Assignments

I/O Port	Read	Write
280H	Status	Control-2
281H	Data	Data
282H	CRC byte	Address MSB (CRC select)
283H	<Reserved>	Address LSB
284H	DMA, Intrpt. Status	DMA, Intrpt. Enable
285H	<Reserved>	Control-1

Table 7.1

NOTES

## Appendix I

### Glossary of Terms

**ALLOCATION UNIT** The unit of disk media (in bytes) which is used by DOS (and other operating systems) to calculate the availability and usage of disk space. It is the minimum number of bytes of disk media allotted to each directory entry or file name. The allocation unit is the basis of all entries in the File Allocation Table (FAT).

**APPLICATION** A program or series of programs that perform(s) functions specific to a user's needs e.g., stock market analysis, inventory control and order-entry.

**BIT** A binary digit (i.e., a logical "1" or "0".)

**BOOT** (bootstrap loading) The process by which a programmed loader or operating system is installed in the CPU's main memory. Also known as IPL or Initial Program Loading.

**BOT** Beginning of tape.

**BUFFER** An area of storage (or memory) that temporarily holds data to be transferred to or from the CPU or any other I/O device.

**BYTE** A group of eight bits (or binary digits).

**CACHE MEMORY** A method of improving the effective data transfer rate to and from the CPU, essentially hidden and transparent to the user. The likely reuse of data requested by the CPU is anticipated by copying that specific data into an area of main memory that has been allocated as cache memory.

**CPU** Central Processing Unit.

**CRC** (Cyclic Redundancy Check) A method of data validation in which all characters of a data block (10 K bytes) are treated as a serial string of bits representing a binary number. This number is divided (modulo 2) by another binary number, which is determined by controller hardware, yielding a remainder which is the CRC character. This CRC character (40 bits) is compared to a check character which has been calculated by the controller in a similar fashion. If the result of this comparison is true, the data is assumed correct, if false, the controller repeats the operation.

**CRC TIME** The amount of time required to generate a CRC for a single data block.

**DIRECTORY** A portion of disk media used by DOS (and other operating systems) to create an index for the data found on that logical drive. The DOS directory is organized by file name. Each entry in the directory created by DOS is 32 bytes long and contains the file name (and extension, if one exists), an attribute byte (designating hidden or "system" files), the date the file was created, the first Allocation Unit number, and the file size in bytes.

**DMA (Direct Memory Access)** A technique of data transfer in which the host CPU will issue a single transfer request for a large block of data. The CPU does not service the peripheral device again until the entire data block has been transferred, allowing it to perform other operations being requested. The TALLGRASS DMA controller provides for chaining, which permits multiple blocks of data to be transferred to main memory with a single CPU command.

**EOT** End of tape.

**ERROR** Any condition which exists in the hardfile system that may cause the improper reading or writing of data.

**FORMAT** A special non-data, sync character or "preamble" which is encoded by the controller in order to separate data blocks. The "preamble" or format character (typically 128 bytes long) is written immediately preceding each 10K byte data block.

**GCR (Group Code Recording)** A method of data encoding in which each byte of data is split into two (2) four bit nibbles and then translated into a five (5) bit code by accessing a translation table (found in controller ROM). This "encoded" data is then written onto the disk media as a serial string of bits. The reading of data from the disk media employs the inverse of the GCR write process. The GCR process is the HardFile Systems' first level of error detection.

**HEAD** The component(s) of the disk or tape drive which convert electrical energy into magnetic energy (or vice-versa) necessary for the transfer of data to and from the disk media or magnetic tape.

**LANDING ZONE** An area of disk media where no data can ever reside, which provides a location for positioning the heads when the system is to be transported or powered down.

**NIBBLE** A group of four bits (or 1/2 of a byte).

**PARTITION** A portion of disk media designated as one logical drive. A partition is always greater than or equal to one surface of disk media.



**PLATTER** A component of the hard disk drive which rotates on a spindle, and consists of two (2) surfaces of disk media.

**RZ** (Recording Zone) The portion of magnetic tape upon which data resides.

**SECTOR** The amount of disk media required to store 512 bytes (typically) of data.

**TRACK** Specific concentric circles of disk media or longitudinal lines of magnetic tape upon which the read/write access heads are positioned when transferring data to or from the drive(s).

**WZ** (Warning Zone) That portion of magnetic tape upon which data cannot reside, whereas beginning or end of tape is eminent.

## NOTES

Appendix II

Technical Support Bulletins

## NOTES

## Appendix III

### Additional Operating Notes

**Drive Size--** Under IBM's implementation of DOS 2.0, devices larger than 30 Mb are not possible since no provision is made in the DOS bootstrap for use of sectors larger than 512 bytes. This requires that 35 and 70Mb HardFiles be partitioned into volumes of 30Mb or less.

**Command Compatibility--** Some of the DOS commands, for example, FORMAT, DISKCOPY and DISKCOMP, will not work in conjunction with the HardFile, or may work with confusing results.

DISKCOPY and DISKCOMP are designed specifically for use with diskette devices only and must not be used with HardFile devices.

FORMAT is also specifically for use with diskettes only, and should not be used where a HardFile device is designated A: or B:. FORMAT contains its own private drivers for the diskette format functions per se, but when FORMAT attempts to install the directory and/or system files on the new diskette it uses BIOS and attempts to reference the diskette as A: or B: without realizing the A:/B: may now be redefined as a HardFile device. As such, FORMAT will install a new floppy directory on the existing HardFile device and destroy the HardFile's directory.

To be safe, FORMAT, DISKCOPY and DISKCOMP should never be used with the modified system made by TGSYS. Instead, always reboot with unmodified DOS before using these programs.

## NOTES

## Appendix IV

### Interface Requirements

The HardFile connects to the host computer through its integral 34 conductor ribbon-cable and separate host Interface Circuit Board. The host Interface Circuit Board allows the host computer to exert control over the HardFile by setting and sensing the various control, status, and data bits within the HardFile's controller (Figure A-IV.1).

The host interface and operating system is required to set control bits in two Control Registers, read status bits from the Status Register (Figure A-IV.2) and read and write data bytes in the track buffer. The Control Registers consist of octal latches, and the host interface essentially has direct access to the data, latch and clear pins on these registers. RC noise filtering is performed on the RESET, WC1S and WC2S lines on the Buffer Board to ensure clean, proper control on the bus. The Status Register is connected to a bi-directional bus that is controlled by the RSE signal.

The data buffer is addressed by a 14-bit counter. This counter may be preset to a given address by using CLK, WAHS and WALS signals. In this manner any byte(s) of a record, sector or track may be accessed. The address counter may be incremented by a pulse on the CLK, in conjunction with CE. The host interface performs an "auto-increment" of the buffer address during a read or write operation by sending simultaneous strobes to the CLK and RDE or WDS lines while holding the CE line low.

To step the disk drive actuator mechanism "in" or "out", the host CPU must generate the individual step pulses and timing using the Step bit while observing the step rate specifications of the disk unit. With the Self-Step option, stepping begins in response to setting the Step bit in the Control-2 Register.

A physical read/write operation occurs in response to setting the Start bit in the Control-2 Register. The R/W operations begin automatically in response to Start, and the host may monitor the R/W Complete bit in the Status Register while waiting for the operation to terminate. During data transfer of a R/W operation, the host should not access the track buffer of the address counter since that action would disrupt the proper functioning of the controller during the R/W operation.

PIN#	SIGNAL	DESCRIPTION	IN/OUT	LOADING
1-8 10	D0 - D7 BUSY	Data Bus for all data & status. Goes minus during Seek, Read, Write or CRC generate.	Bi-Dir Output	4 LSTTL N/A
12	$\overline{\text{RCE}}$	Read CRC enable. Gates selected CRC byte onto bus.	Input	2 LSTTL
14	$\overline{\text{RSE}}$	Read STATUS enable. Places 8 bits of Controller or Drive status on the bus.	Input	2 LSTTL
16	$\overline{\text{RDE}}$	Read DATA enable. Places next byte in the Buffer on the bus.	Input	2 LSTTL
18	$\overline{\text{WC1S}}$	Write CONTROL-1 strobe. Stores data which is on the bus into Control-1 Register.	Input	1 LSTTL
20	$\overline{\text{WDS}}$	Write DATA strobe. Stores data at present addressed Buffer location.	Input	1 LSTTL
22	$\overline{\text{WAHS}}$	Write Address High. Used with CLK to preset MSB address into Buffer Address Counter.	Input	2 LSTTL
24	$\overline{\text{WC2S}}$	Write CONTROL-2 strobe. Stores data which is on the bus into Control-2 Register.	Input	1 LSTTL
26	$\overline{\text{WALS}}$	Write Address Low. Used with CLK to preset LSB address into Buffer Address Counter.	Input	2 LSTTL
28	$\overline{\text{CLK}}$	CLOCK used to Count & Preset Address Counters for the Data Buffer.	Input	1 LSTTL
30	$\overline{\text{RESET}}$	Clears Control Registers.	Input	1 LSTTL
32	$\overline{\text{CE}}$	Count Enable. Enables Buffer Address Counters to respond to CLK. Used by Host for AUTOINCREMENT feature of WDS & RDE.	Input	1 LSTTL
9, 11, 13, 15, 17, 19, 21, 23, 25, 27, 29, 31 & 33 are all GROUND Returns				

Figure A-IV.1 I/O Signal Definition

	Registers							
	7	6	5	4	3	2	1	0
STATUS-1 REGISTER	R/W Busy	Decoder Error	TRK 000	Seek Complete	Write Protect	Write Fault	Drive Ready	Drive Indent
CONTROL-1 SELECT REGISTER	Head Select 3	Head Select 2	Head Select 1	Head Select 0	Backup Enable	Winch Enable	Drive Select 1	Drive Select 0
CONTROL-2 START REGISTER	Reverse	Motor	Direction 1=In	Step (Start)	Reduce Write 1	CRC Start	Read=0 Write=1	R/W Start

Figure A-IV.2 Register Definition



NOTES

NOTES



