



# GAMEWAVE 32



© 1994, Orchid Technology. This manual is copyrighted. All rights reserved. This document may not, in whole or part, be copied, reproduced, reduced or translated by any means, either mechanical or electronic, without prior consent in writing from Orchid Technology, Incorporated.

GameWave 32 and Orchid are trademarks of Orchid Technology. All other products mentioned in this manual are trademarks of their respective manufacturers.

Orchid Technology  
45365 Northport Loop West  
Fremont, CA 94538-9973



---

# GameWave 32

User's Manual



---

## TABLE OF CONTENTS

|                          |   |
|--------------------------|---|
| <b>Foreword</b>          | 5 |
| <b>Introduction</b>      | 6 |
| <b>About This Manual</b> | 7 |
| <b>Before You Begin</b>  | 8 |

### SECTION 1

|  |          |
|--|----------|
| <b>Installing the GameWave 32</b>          | <b>9</b> |
| Figure 1.1: GameWave 32 Diagram            | 10       |
| <b>Step 1: Preparing Your Computer</b>     | 11       |
| <b>Step 2: Preparing Your GameWave 32</b>  | 11       |
| Table 1.1: Summary of Jumper Settings      | 11       |
| <b>Jumper Settings</b>                     | 11       |
| Figure 1.2: Jumper J3: I/O Address         | 12       |
| Figure 1.3: Jumper J12: Wavetable          | 12       |
| Wavetable Configuration                    | 13       |
| <b>Step 3: Installing Your GameWave 32</b> | 14       |
| Figure 1.4: Rear Slot Cover                | 14       |
| Connecting External Speakers               | 14       |
| Figure 1.5: GameWave 32 Bracket            | 15       |
| External Devices                           | 16       |
| <b>Installing the Orchid CD-ROM Drive</b>  | 17       |
| Figure 1.6: CD-ROM Drive Installation      | 17       |
| Figure 1.7: CD-ROM Back Panel              | 18       |
| Figure 1.8: Audio Cable                    | 18       |
| <b>Operating Your Orchid CD-ROM Drive</b>  | 19       |
| Front Panel Operation                      | 20       |
| Figure 1.9: CD-ROM Front Panel             | 20       |
| Back Panel Operation                       | 20       |
| Disc Handling                              | 21       |

---

|                                       |    |
|---------------------------------------|----|
| Installing GameWave 32 Device Drivers | 21 |
| <b>Installing Other CD-ROM Drives</b> | 21 |
| Guidelines                            | 23 |
| <b>The MIDI Interface</b>             | 24 |
| Figure 1.10: MIDI Adapter Cable       | 24 |

## SECTION 2

|  |           |
|--|-----------|
| <b>Driver Installation</b>                   | <b>27</b> |
| <b>Before You Begin</b>                      | 27        |
| <b>Using GINSTALL.EXE</b>                    | 28        |
| Figure 2.1: GINSTALL Main Menu Screen        | 28        |
| Figure 2.2: GameWave 32 Configuration Screen | 29        |
| Device Drivers                               | 31        |
| Changing the Address Settings                | 33        |
| GW32.EXE Utility                             | 33        |

## SECTION 3

|                                      |           |
|--------------------------------------|-----------|
| <b>Technical Help</b>                | <b>35</b> |
| CompuServe                           | 35        |
| Before You Begin                     | 35        |
| Troubleshooting GameWave 32          | 36        |
| Avoiding Address Conflicts           | 41        |
| MIDI Usage                           | 42        |
| <b>Technical Information</b>         | <b>43</b> |
| GameWave 32 Technical Specifications | 43        |
| Features                             | 43        |
| Additional Features                  | 44        |

---

|   |           |
|---|-----------|
| <b>Address Settings and Pin Assignments</b> | <b>46</b> |
| CD-ROM Addresses                            | 46        |
| Table A1: CD-ROM Addresses                  | 46        |
| Sound Blaster Mode Addresses                | 46        |
| Table A2: Sound Blaster Mode Addresses      | 46        |
| MPU-401 Mode Addresses                      | 47        |
| Table A3: MPU-401 Addresses                 | 47        |
| CD-ROM Audio Cable Connector                | 47        |
| Table A4: CD-ROM Audio Cable Pin-Outs       | 47        |
| Joystick-MIDI Pin Assignments               | 48        |
| Table A5: Joystick/MIDI Pin Assignments     | 48        |
| Figure A1: Joystick/MIDI Pin-Outs           | 48        |
| GameWave 32 MIDI Port Specifications        | 49        |

## **APPENDIX A**

|                   |           |
|-------------------|-----------|
| <b>Game Hints</b> | <b>51</b> |
|-------------------|-----------|

## **APPENDIX B**

|                               |           |
|-------------------------------|-----------|
| <b>MIDI</b>                   | <b>53</b> |
| MIDI Overview                 | 53        |
| GameWave 32 Sounds            | 54        |
| GameWave 32 Percussion Sounds | 58        |

## **APPENDIX C**

|                                |           |
|--------------------------------|-----------|
| <b>Glossary</b>                | <b>61</b> |
| <b>Limitation of Liability</b> | <b>67</b> |
| <b>FCC Notice</b>              | <b>68</b> |
| <b>Index</b>                   | <b>69</b> |



---

Orchid Technology has been a leading manufacturer of hardware and peripherals for personal computers since its incorporation in 1982, and is noted for introducing new standards to the personal computer industry:

- 1982    **PCnet:** the first personal computer Local Area Network.
- 1984    **PCturbo:** the first Accelerator card for PC-compatible computers.
- 1985    **ECCELL:** the first PC Multifunction card with error correction.
- 1987    **RamQuest 50/60:** the first EMS (Expanded Memory Specification) product for the IBM PS/2 computers.
- 1990    **ProDesigner II:** the first Super VGA graphics adapter to support 1024 x 768 graphics in 256 colors on interlaced *and* non-interlaced monitors.
- 1991    **Fahrenheit 1280°:** first to ship a Windows accelerator, based on S3's 86C911 chip.
- 1992    **Fahrenheit VA:** first to ship a Windows accelerator with video audio built-in.
- 1993    **Celsius/VLB:** first to ship a Windows accelerator based on IIT's award-winning AGX015 chip.

GameWave 32™ brings *incredible* sound to all of your entertainment software. It is a high-performance 16-bit stereo sound card for 286, 386, and 486 personal computers. The GameWave 32 combines complete multimedia compatibility with simultaneous sound standards support. It features a wavetable synthesizer *for authentic sounds*, and supports the following sound and multimedia standards: SoundBlaster, General MIDI, AdLib, Roland MPU-401 interface and Roland MT-32.

Thank you for purchasing GameWave 32. Care has been taken to ensure that it will provide you with years of trouble-free operation. We believe you will be pleased with your purchase.





---

## INTRODUCTION

The GameWave 32 is an advanced DSP-based (Digital Signal Processor) multimedia sound card. GameWave 32 supports several sound and multimedia standards—SoundBlaster, General MIDI, AdLib, Roland MPU-401 interface and Roland MT-32. These emulation modes are selectable, making it easy to configure your GameWave 32 for games and multimedia applications.

For realistic sounds, GameWave 32 has over two megabytes of high-quality sound samples on-board. These samples can be used by games or multimedia applications under the General MIDI specification.

The GameWave 32 is based upon the Analog Devices ADSP2115 DSP. This advanced chip can process over 20 million instructions per second (20 MIPS), enabling GameWave 32 to accurately emulate a wide number of sound and synthesizer architectures, including Yamaha's OPL synthesizers and the Roland MT-32 sound module.

GameWave 32's flexible architecture provides the ability to switch between sound standards and to update to new sound standards without additional hardware. In addition, GameWave 32 features dual CD-ROM interfaces for Sony and Mitsumi compatible CD-ROM drives.

---

## About This Manual

This manual presumes that you are already familiar with your IBM PC-compatible computer. While the GameWave 32 has been designed to be easy-to-install, we recommend that you refer to your computer's reference manual when terminology or installation steps are unfamiliar to you.

Each section is divided into short, easy-to-follow steps, to help you understand the installation and function of the GameWave 32.

### Section 1: Installing the GameWave 32

Whether you are a beginner or an experienced user, this section will give you important information on proper installation, and instructions on how to connect external devices to the GameWave 32.

### Section 2: Software Installation and Setup

Here you will be given the information needed to install the sound drivers and configure hardware settings.

### Section 3: Technical Help and Information

If you are experiencing installation difficulties or require troubleshooting information, this section will give you checkpoints to ensure that your GameWave 32 is operating properly. Section 3 also includes the technical specifications for GameWave 32.

### Appendix A: Game Hints

This section provides suggestions for configuring emulation modes for games.

### Appendix B: MIDI

Here you are given an overview of the MIDI specification and a list of sounds used on GameWave 32.

### Appendix C: Glossary

This section provides a list of terms with their definitions.

---

## *Before You Begin*

This manual will familiarize you with the features, installation and use of the GameWave 32. There are several symbols and conventions used throughout this manual which will help to draw your attention to a feature or to focus on important information:



When you see the Magnifying Glass it means the text is referring to something you should take a closer look at before proceeding further.

**FILENAME** All MS/PC DOS filenames and DOS commands will be emphasized by this type style.

### Common Names

|      |   |
|------|---|
| BBS  | Bulletin Board System   |
| DSP  | Digital Signal Processor  |
| MIDI | Musical Instrument Digital Interface                                |
| MPC  | Multimedia PC   |
| PC   | Refers to the family of IBM PC, PC/XT or PC/AT compatible computers |

Chapter

# 1

## INSTALLING GAMEWAVE 32

GameWave 32 is designed to be easy-to-use and easy-to-install. Before installing GameWave 32 into your computer, make sure that it will not conflict with existing components. See Section 3 for help on checking for potential conflicts.

There are three fundamental steps to the installation. These steps are explained in detail on the following page.



### **STATIC!**

*Before handling the GameWave 32, be sure to guard against electrostatic discharge. Do not wear clothing that causes static (such as wool sweaters). In most cases, touching the power supply housing before handling the board will discharge static electricity, or you may want to buy a Ground strap from your local computer store.*

### Step 1: Preparing your Computer

You will need to take the cover off your computer and select a 16-bit expansion slot for GameWave 32.

### Step 2: Preparing your GameWave 32

GameWave 32 can be installed using the preset jumper settings. The jumpers are used to configure the hardware I/O and the Wavetable ROM chip size. If you need to change the default settings, see Table 1.1 for other options. Other addresses used are software configured.

### Step 3: Installing your GameWave 32

GameWave 32 allows for connection of various external devices, such as a CD-ROM drive, speakers, joystick and MIDI connections. See Figure 1.1 for connection locations. This step also provides installation instructions for the MIDI interface connection.

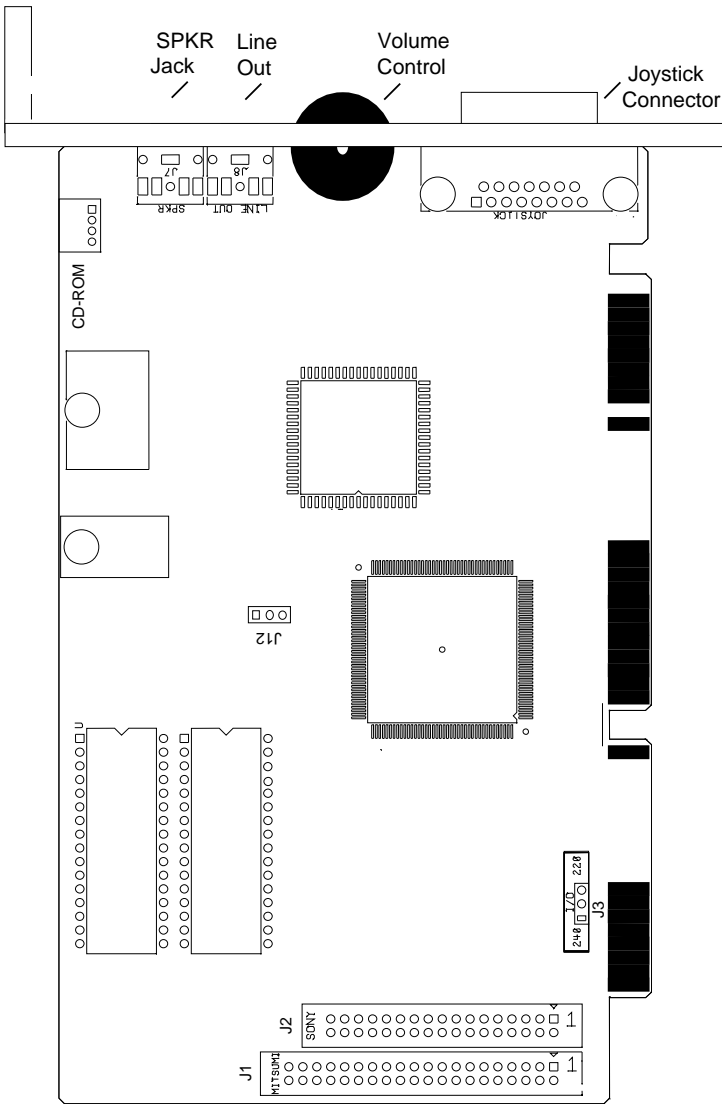

Figure 1.1: GameWave 32 Diagram

**NOTE:** Pin 1 on the card is indicated by a square

## Step 1: Preparing Your Computer

1. Turn off the power to your computer and disconnect all of the power cords and cables from the computer.
2. Remove the screws that secure the computer chassis cover and slide the cover off. Be sure to keep the screws in a safe place.
3. Select a 16-bit expansion slot for GameWave 32.

## Step 2: Preparing Your GameWave 32

| Jumper     | Setting       | Default | Function   |
|------------|---------------|---------|--|
| Jumper J3  | Connect 1 & 2 | ✓       | Enable I/O address 240<br>Enable I/O address 220                                 |
|            | Connect 2 & 3 |         |  |
| Jumper J12 | Connect 1 & 2 | ✓       | Enable 2MB Wavetable (for optional 1MB ROMS)<br>Enable 1MB Wavetable (512K ROMS) |
|            | Connect 2 & 3 |         |  |

Table 1.1: Summary of Jumper Settings

### Jumper Settings

There are two jumper blocks used in the configuration of GameWave 32. The jumpers are located at positions J3 and J12. The following information explains the use and proper settings of each jumper.

### Jumper J3: I/O Address

Jumper J3 sets the base port address for Sound Blaster mode. This I/O address is used to load the DSP (Digital Signal Processor) code to the DSP. The default setting is 220 Hex.



For help on avoiding address conflicts, see Section 3.

**Figure 1.2:** Jumper J3 (pins 2 and 3 connected). *Default address*

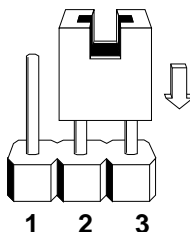

If you need to change the default address, connect pins 1 and 2 to select the optional address—240 Hex.

### Jumper J12: Wavetable

There are two 512K Wavetable ROM chips on the GameWave 32, which stores 2MB of compressed sample sounds. The DSP on the card decompresses the sample sounds when it plays them.

The default setting of 512K gives you 2MB of authentic instrument recordings. The 1MB setting is for the optional 4MB of sample sounds. Refer to Table 1.2.

**Figure 1.3:** Jumper J12 (pins 2 and 3 connected). *Default address*

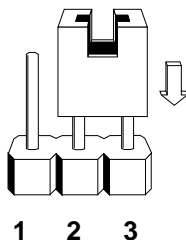

To configure for the optional 4MB of sample sounds, connect pins 1 and 2 to select the 1MB address setting.

### Wavetable Configuration

The following table details the Wavetable configuration of the GameWave 32. The configuration is defined as follows:

| Sample Sound Size | Compressed Size | ROM Size  |
|-------------------|-----------------|-----------|
| 2MB (1MB x 16)    | 1MB             | 2 x 512KB |
| 4MB (2MB x 16)    | 2MB             | 2 x 1MB   |

**Table 1.2:** Wavetable Configuration

*where:*

Sample Sound Size = actual sample size

Compressed Size = size of samples

ROM Size = chips used to store the sample set



### Step 3: Installing Your GameWave 32

*If you are connecting a CD-ROM drive, go to the section "Installing the Orchid CD-ROM Drive," otherwise continue on.* Once you have checked your GameWave 32 jumper settings, you are ready to install GameWave 32 and any external devices.

1. Select a 16-bit expansion slot for GameWave 32.
2. Remove the rear slot cover bracket if it is present. Keep the screw for future use.

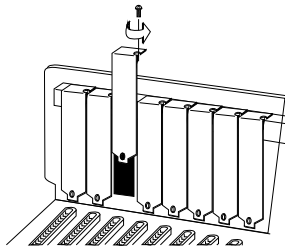

**Figure 1.4:** Rear slot cover

3. Carefully hold GameWave 32 by the top edges and lower it into its expansion slot. Ensure that the GameWave 32 seats firmly into the slot, and that it aligns properly with the computer's backplane.
4. Secure the GameWave 32 in place by fastening its metal bracket to the computer backplane (using the screw you removed in # 2).
5. Reconnect previously removed cables and power cords and replace the cover of the computer.

#### Connecting External Speakers

6. If you are connecting external speakers to the GameWave 32, connect the speaker cable to the SPEAKER jack on the metal bracket (see Figure 1.5).

7. If you are connecting amplified external speakers to the GameWave 32, connect the speaker cable to the LINE OUT jack on the metal bracket.

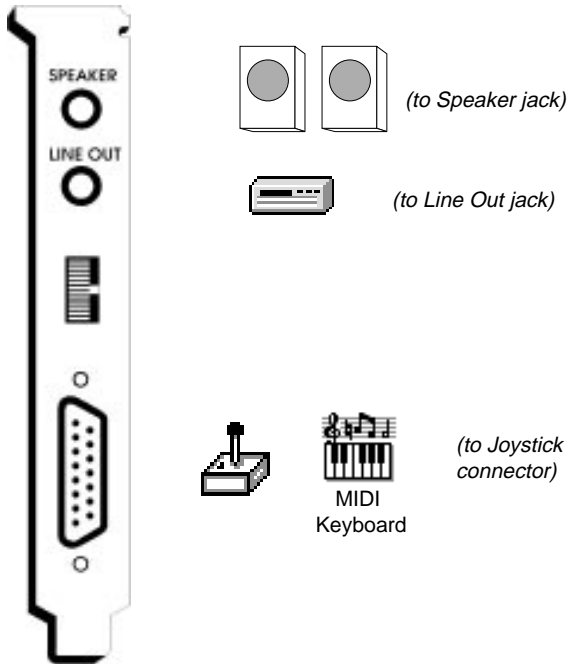

Figure 1.5: GameWave 32 Bracket

### External Devices

#### **External Speakers**

You can connect 4 or 8 ohm external speakers or headphones to GameWave 32. The speakers and headphones plug into the SPEAKER jack on the GameWave 32 metal bracket.

#### **Line Out**

Allows you to connect the audio output of your GameWave 32 to your home stereo or VCR.

#### **Joystick**

Plug the joystick into the 15-pin connector on the GameWave 32 metal bracket.

#### **MIDI**

If you purchased the optional MIDI interface kit, you will have an additional cable. This cable plugs into the 15-pin connector and provides MIDI IN and MIDI OUT connections, in addition to a joystick connection. Connect this cable to the joystick port and connect any MIDI devices to the appropriate cables.

#### **CD-ROM**

GameWave 32 supports both internal and external CD-ROM drives. It has interface connectors for the Mitsumi and Sony internal CD-ROM drives. To connect an internal drive, see "Connecting the Or-chid CD-ROM Drive."



See Figure 1.5 for the connection locations of the external devices.



Be sure to plug in all cables before powering up your PC.

### Installing the Orchid CD-ROM Drive

*If you are installing a CD-ROM drive other than an Orchid CD-ROM drive, go to the section "Installing other CD-ROM Drives." Before starting the setup and installation, make sure that your computer is turned OFF and the power cord has been disconnected from the wall outlet. Your CD-ROM drive kit should contain the following items for a successful installation:*

- CD ROM Drive with optional slide rails
- Interface Cable
- Audio Cable

#### To Install the CD-ROM Drive:

1. If needed, attach the slide rails to the side of the CD-ROM drive (screws are included). Slide rails are necessary for some computers with large AT-style cases.
2. Uncover a 5.25" half-height drive bay on the computer, and remove the screws and brackets from both sides of the drive bay.
3. Slide the CD-ROM drive into the half-height slot, and secure the drive in place with either screws and brackets provided with your computer or the mounting screws provided with the drive.



*For installation of your CD-ROM drive, you will need a Phillips-head screwdriver as well as a flathead screwdriver.*

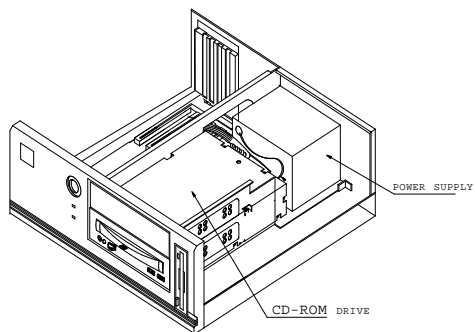
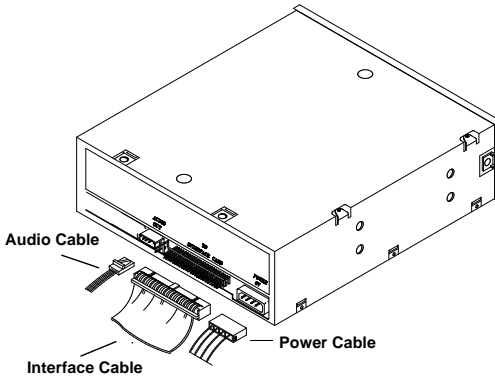

**Figure 1.6:** CD-ROM Drive Installation

4. Connect one end of the interface cable (ribbon-type) to the Orchid CD-ROM drive interface connector. Be sure to match the colored stripe to Pin 1 of the CD-ROM drive connector. **NOTE:** Pin 1 is close to the power connector.



*Try to avoid excessive twists or bends in the cable that might damage it or interfere with other boards in your computer.*



**Figure 1.7:** CD-ROM Back Panel

5. Connect the other end of the cable to connector J2 on the GameWave 32 card. Pin 1 is located on the bottom right corner of the connectors. Make sure that Pin 1 on your cable (colored stripe) is connected to this pin.
6. Connect the three-pin end of the audio cable to the CD-ROM drive's three-pin audio connector.



**Figure 1.8:** Audio Cable

7. Connect the four-pin end of the audio cable to the CD-ROM audio connector on the GameWave 32 (see Figure 1.1).

8. Connect the DC power cable from the PC's power supply to the DC power connector at the rear of the CD-ROM drive. When all of these steps are complete, your CD-ROM drive should be connected to your PC's power supply and to your GameWave 32.
9. At this point, carefully hold the GameWave 32 by the top edges and lower it into its expansion slot. Ensure that the GameWave 32 seats firmly into the slot, and that it aligns properly with the computer's backplane. Be very careful that the cables attached to the card don't get tangled or pinched.
10. Secure the GameWave 32 in place by fastening its metal bracket to the computer backplane with the screws that were removed.
11. If you are connecting external speakers to the GameWave 32, see Figure 1.5 for connection locations.
12. Reconnect previously removed cables and power cords, and replace the cover of the computer.



*Be sure to plug in all cables before powering up your PC.*

The Orchid CD-ROM drive and GameWave 32 installations are complete.

### Operating Your Orchid CD-ROM Drive

1. Press the eject button to open the CD tray (see Figure 1.9).
2. Place the CD-ROM disc in the center of the tray.
3. Close the tray by either pressing the eject button again, or gently pushing the tray in.

The drive should now be in its normal operating position.

### Front Panel Operation

The controls for the front panel of the Orchid CD-ROM Drive are as follows (left to right):

- Headphone - for attaching a headphone.
- Power LED - lights while data is read from disc; blinks during seek operation.
- Volume Control - adjusts headphone sound level.
- Quick Select - the right button has three modes: EJECT, CLOSE and STOP. The left button has two modes: PLAY and SKIP to the next track.

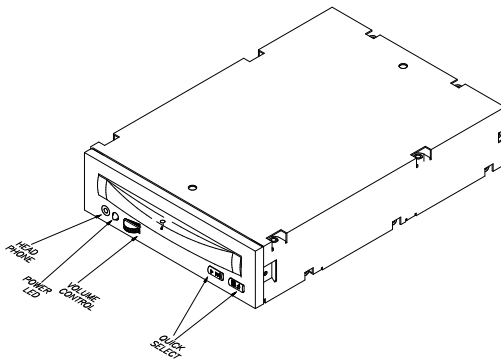

**Figure 1.9:** CD-ROM Front Panel

### Back Panel Operation

The controls for the back panel of the Orchid CD-ROM Drive are as follows (refer to Figure 1.7):

- Audio Out - three-pin connector.
- To Interface Card - connector for 34-pin ribbon interface cable.
- Power - provides power to the CD-ROM drive from a standard power supply.

### Disc Handling

- Handle the disc only by its edges. Do not touch the surface of the disc.
- Never write on a disc with a hard object, such as a ball-point pen or pencil, and never affix any label directly on a disc.
- Never bend a disc.
- Do not use or store a disc in areas subjected to high temperatures or humidity.
- Store a disc in its case to avoid dust contamination, scratches, bending or other damage.
- For best results, periodically wipe each disc with a soft, dry cloth, gently rubbing outward from the center.

### Installing GameWave 32 Device Drivers

You are now ready to install the software and test the drive. In order to access the CD-ROM drive, three device drivers are required:

SWCD.SYS  
CDD.SYS  
MSCDEX.EXE

Installing the device drivers and other software is a simple task. Refer to Section 2—Driver Installation and Setup, for automatic installation of the CD-ROM Device Drivers.

### Installing Other CD-ROM Drives

The following information is an installation process for an internal CD-ROM drive. This information is not meant to replace the manuals that came with your



drive. This information, however, will outline the basic steps of installing an internal CD-ROM drive. Your CD-ROM drive kit contains the necessary hardware, audio and interface cables in addition to the CD-ROM drivers you need to work with the CD-ROM drive.

### To Install an Internal CD-ROM Drive:

1. Make sure your system is turned off, and unplug all power cords.
2. Check your CD-ROM drive's address settings. The address settings are configured at the factory with default settings. Refer to your CD-ROM drive installation manual for altering the settings or for troubleshooting information.
3. Install the drive into an available drive bay. Slide the drive in, and screw it to the drive frame.
4. Attach the power, interface connector and audio cables to the CD-ROM drive. Refer to your CD-ROM Drive's installation manual for these steps.
5. Connect the interface connector cable to the Mitsumi (J1) or Sony (J2) interface connector on GameWave 32.
6. Connect the audio cable to the CD-ROM audio connector on GameWave 32.
7. At this point, carefully hold the GameWave 32 by the top edges and lower it into its expansion slot. Ensure that GameWave 32 seats firmly into the slot, and that it aligns properly with the computer's backplane. Be very careful that the cables attached to the card don't get tangled or pinched.
8. Secure GameWave 32 in place by fastening its metal bracket to the computer backplane with the screws that were removed.
9. If you are connecting external speakers to the



*For installation of your CD-ROM drive, you will need a Phillips-head screwdriver as well as a flathead screwdriver.*

GameWave 32, see Figure 1.5 for the connection location.



*Be sure to plug in all cables before powering up your PC.*

10. Replace the cover of the computer along with the previously removed cables and power cords.
11. When all of these steps are complete, your CD-ROM drive should be connected to your PC's power supply and to the GameWave 32. For instructions on operating your CD-ROM drive, refer to your CD-ROM drive installation manual.
12. Install the device drivers that came with your CD-ROM drive. For example, if you are using a Sony drive, use the Sony CD-ROM drivers. If you are using a Mitsumi drive, use the Mitsumi CD-ROM drivers.

To access the CD-ROM drive, the MSCDEX.EXE driver must be added to your AUTOEXEC.BAT file. Refer to Section 2: Device Drivers for information on installing the MSCDEX.EXE driver, and for details on the device driver parameters.



*The SWCD.SYS device driver must be loaded before any other CD-ROM device driver. See Section 2.*

**NOTE:** Refer to your CD-ROM drive documentation for installing appropriate device driver(s) and parameters for your drive. For example, the following lines must be added to your CONFIG.SYS file:

***For the Sony drive:***

```
Device=C:\GW32\SWCD.SYS /i:9 /a:360
```

```
Device=C:\Sony\SLCD.SYS /d:Sony-000 /b:340 /m:p /v /c
```

***For the Mitsumi drive:***

```
Device=C:\GW32\SWCD.SYS /i:9 /a:360
```

```
Device=C:\Dev\MITMCD.SYS /d:MSCD001 /p:360 /a:0
```

### Guidelines

Use the following guidelines to configure your CD-ROM device driver:

- 👉 The CD-ROM drive name (/d:) must match the MSCDEX.EXE drive name.
- 👉 You must use Programmed I/O mode when using Sony or Mitsumi CD-ROM drives. This is the IRQ and I/O address settings, not the DMA setting.
- 👉 The CD-ROM driver must match the IRQ and I/O settings in the GW32 /C program, and the SWCD.SYS device driver line in your CONFIG.SYS file.

### The MIDI Interface

An optional MIDI kit is available for the GameWave 32. The kit includes a Sound Blaster-type MIDI cable and MIDI software. To purchase the kit call our Customer Service department.

#### To connect the MIDI cable:

To connect GameWave 32 to a MIDI keyboard (or synthesizer), you need to plug the MIDI adapter cable to the GameWave joystick connector. Follow the instructions below:

1. Connect the joystick/MIDI adapter cable to the joystick port on the GameWave 32 bracket (see Figure 1.5).

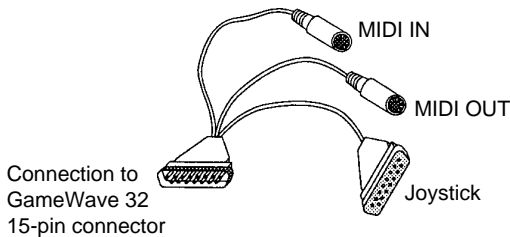

**Figure 1.10:** MIDI Adapter Cable



*For an overview of the MIDI specification, see Appendix A.*



*The MIDI input connector goes to the MIDI output connector of equipment such as a MIDI keyboard. The MIDI output connector goes to the MIDI input connector of a MIDI device such as a synthesizer.*

2. If you are using a joystick, connect it to the 15-pin joystick connector on the adapter cable.
3. Connect the MIDI device(s) to the MIDI connectors on the adapter cable.



Section

# 2

## DRIVER INSTALLATION AND SETUP

GameWave 32 comes with drivers for several multi-media sound standards—Sound Blaster, AdLib, General MIDI, Roland MPU-401 MIDI and Roland MT-32, for use in DOS and Windows. For example, in the Windows environment, GameWave 32 can be set to emulate the Sound Blaster standard while simultaneously supporting General MIDI wave synthesis and the Roland MPU-401 MIDI interface specifications. Under DOS, GameWave 32 can be configured as a Sound Blaster for games, and an MPU-401 MIDI for music applications.



*This manual presumes that you are already familiar with the basics of Microsoft Windows. Please refer to the Microsoft manual when terminology or installation steps are unfamiliar to you.*

The sound drivers are automatically installed using the GINSTALL.EXE program. See the instructions for GINSTALL to automatically install the GameWave 32 drivers. In addition, the GINSTALL program provides easy configuration of the GameWave 32 drivers, and recommendations for use with network servers.

### Before You Begin

It is recommended that you install the GameWave 32 software on your hard drive. The software is in a compressed format, and is automatically decompressed during installation.



*If you wish to make a backup copy of your original diskettes, use the DOS DISKCOPY utility command.*

The instructions that follow assume you are using a floppy drive, designated as Drive A:, and a hard drive, designated as drive C:. Please substitute the correct drive letter if your computer is configured differently.

### Using GINSTALL.EXE

GINSTALL.EXE is an easy-to-use menu driven installation program, which allows you to automatically install the GameWave 32 software and drivers to your hard disk drive. Insert the GameWave 32 Diskette into your drive A: and type the following:

A: \GINSTALL 

From the GameWave 32 and CD-ROM Driver Installation menu, press any key, and the following menu will appear:



*If you are installing GameWave 32 into a system that had another sound card previously installed, remove all drivers and files for that sound card.*

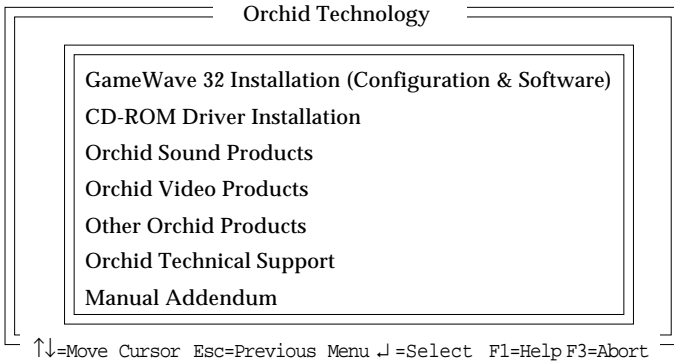

**Figure 2.1:** GINSTALL Main Menu Screen

From the Main Menu, select your installation choice by using the <↑↓> arrow keys and press <ENTER>. Proceed through the installation as prompted by the GINSTALL.EXE program.

The GameWave 32 Installation option copies the GameWave 32 drivers and configuration utilities to your hard drive. You are prompted to answer YES or NO to whether you have installed a CD-ROM drive. Responding NO only copies over the GameWave 32 drivers and configuration utilities. The following screen appears:

| GameWave 32 Configuration                             |                                | ver. x.xx |       |
|---|--------------------------------|-----------|-------|
| © 1994 Orchid Technology                              |                                |           |       |
| Emulation Mode:                                       | Sound Blaster + General MIDI   |           |       |
| Start Music:  | ON                             |           |       |
| GameWave Joystick Port:                               | Disable                        |           |       |
| SoundBlaster Interface:                               | Port=220                       | IRQ=7     | DMA=1 |
| MIDI (MPU-401) Interface:                             | Port=330                       | IRQ=5     |       |
| CD-ROM Interface:                                     | Port=360                       | IRQ=9     |       |
| <hr/>   |                                |           |       |
| Changes Complete:                                     | Accept the above configuration |           |       |
| F2 = Set all Ports, IRQ's and DMA's to default values |                                |           |       |
| ↑↓=Move Cursor ←=Select Esc=Abort Configuration       |                                |           |       |



*Please write down your configuration settings for future reference.*

**Figure 2.2:** GameWave 32 Configuration Screen

Responding YES copies over the GameWave 32 drivers and configuration utilities and the CD-ROM drivers to your hard drive. A screen will appear and list the statements that need to be added to your CONFIG.SYS and AUTOEXEC.BAT files. You can select the option to modify these files automatically. Once this is complete, the program will exit to the GameWave 32 configuration screen.

The CD-ROM Driver Installation selection should be used if you are adding a CD-ROM drive later. This selection will copy over the CD-ROM drivers to your hard drive, modify your CONFIG.SYS and AUTOEXEC.BAT files, and exit to the GameWave 32 configuration screen.

In order to access your CD-ROM drive, three device drivers are required:

SWCD.SYS  
CDD.SYS  
MSCDEX.EXE



## Section 2: Driver Installation

---

Once the software is installed, the GINSTALL program automatically updates your CONFIG.SYS and AUTOEXEC.BAT files with the following command lines:

### CONFIG.SYS

```
DEVICE=C:\GW32\SWCD.SYS /i:9 /a:360
DEVICE=C:\GW32\CDD.SYS /d:MSCD0001 /p:360
```

### AUTOEXEC.BAT

```
C:\GW32\MSCDEX.EXE /d:MSCD0001 /M:10
```

The GINSTALL program also installs and modifies several files. See the README file on the GameWave 32 software disk for the file names. GINSTALL provides a DEINSTALL feature to remove the GameWave 32 files, drivers and modifications made.

Once the driver installation is complete, you *must* reboot your system. The CD-ROM drive is initialized on bootup. If it does not initialize on bootup, check for an I/O, DMA or IRQ address conflict. Verify the address settings of the other peripherals in your system to correct the address conflict(s).

For DOS and Windows environments, GameWave 32 will automatically operate in the following modes for the best sound and compatibility:

*DOS and Windows* - MPU-401 MIDI, General MIDI and Sound Blaster.



The SWCD.SYS device driver must be loaded before the CD-ROM device driver.



For details on the device driver parameters, see "Device Drivers."

## Device Drivers

For any changes or modifications to the device drivers, you may rerun the GINSTALL program, use a text editor such as MS-DOS "EDIT," or your favorite text editing program. The following syntax is used for the **MSCDEX.EXE** device driver:

```
[drive:\][path\]mscdex.exe /d:device_name [/l:m]
```

The parameters are defined as follows:

**/d:** Specifies the device name of the CD-ROM drive. The driver1 parameter must match the parameter specified by the /D switch on the CONFIG.SYS command that starts the corresponding CD-ROM device driver.

The MSCDEX command must include at least one /D switch. To install additional CD-ROM device drivers, specify an additional /D switch for each device driver.

**/l:** Specifies the drive letter of the first CD-ROM drive. If you have more than one CD-ROM drive, MS-DOS assigns additional CD-ROM drives subsequent available drive letters.

**/m:** Specifies the number of sector buffers.

**/e:** Specifies that the CD-ROM driver use expanded memory, if available, to store sector buffers.

**/k:** Specifies that MS-DOS should recognize CD-ROM volumes encoded in Kanji. By default, MS-DOS does not recognize Kanji CD-ROM volumes.

**/s:** Enables sharing of CD-ROM drives on MS-NET or Windows for Workgroups servers.

**/v:** Directs MSCDEX to display memory statistics when it starts.

## Section 2: Driver Installation

---

The following syntax is used for the **SWCD.SYS** device driver:

```
device = [drive:\] [path\] swcd.sys /i: /a:
```

The parameters are defined as follows:

[drive:\] [path\] specifies the drive and path name where you copied the SWCD.SYS file.

/i: Specifies the interrupt address.

/a: Specifies the I/O address.

The following syntax is used for the **CDD.SYS** device driver:

```
device = [drive:\] [path\] cdd.sys /d:device_name
```

The parameters are defined as follows:

[drive:\] [path\] specifies the drive and path name where you copied the CDD.SYS file.

/d: Specifies the device name of the CD-ROM drive and must be identical to the device name specified by MSCDEX.

/p: Specifies the I/O address.

/i: Specifies the interrupt address.

/v: Turns on verbose mode of the driver. The driver will display information about its installation.

### Changing the Address Settings

If you need to change the GameWave 32 configuration or change the address settings due to conflicts, change to the GW32 subdirectory and run the GW32 /C program. For help on eliminating address conflicts, see Section 3.

### GW32.EXE Utility

The GW32.EXE utility program adds a device driver line in your CONFIG.SYS file that includes the address settings and emulation modes of your GameWave 32. You have the option of changing the hardware settings and the operating mode of GameWave 32 from the DOS command line.

For example, to change the hardware setup values, change to the GW32 subdirectory and type the following:

C:\GW32 /C 

The command line options are as follows:

- /? - A listing of options and syntax
- /C - To change the hardware setup values
- /S - Check the status of the current configuration
- /V:x - Sets the volume, where x is 0 to 31
- GW32 - To set the hardware configuration



Section

# 3

## TECHNICAL HELP

Orchid Technology is known for its responsiveness to its customers. This section gives you helpful hints for troubleshooting the GameWave 32 and the technical specifications.

### CompuServe

In addition to calling Orchid technology, technical support is now available through the CompuServe Information Service (CIS). You can also download drivers and get new product information. To find us on CompuServe, follow the instructions below:

1. Log onto CompuServe.
2. Type GO MULTIB to get into the Multimedia Vendor Forum B. Once you are in this forum, select Message Section #10. The message and library sections are labeled Orchid . . .

or

You may type GO ORCHID to get immediate access to the Orchid section.

3. If you would like to leave private mail for Orchid, type GO MAIL. Address your letters to our technical support account number 72662,2672.



*All commands can be typed in lower or upper case letters.*

### Before You Begin

Because of the unique hardware design of the GameWave 32, each sound standard is independent of the other. This is how GameWave 32 can emulate multiple sound standards simultaneously.

When troubleshooting the GameWave 32 for potential conflicts, it is important to remember that if a sound standard works correctly, the problem generally becomes a software issue. For example, the

startup music with the GW32.EXE program uses the SoundBlaster interface. If the startup music plays, the SoundBlaster interface is operating correctly. If an application that is emulating the SoundBlaster standard is not operating properly, contact the software manufacturer for possible configuration requirements or software updates.

### Troubleshooting the GameWave 32

The following information will help you diagnose problems you may have with the GameWave 32. Following these simple steps serves a two-fold purpose:

You may be able to fix your problem and avoid having to contact the Orchid Technology Technical Support Department...

or

if these steps do not help you solve your problem, they will most certainly give you a better handle on what to tell Technical Support once you do contact them.

The information provided here is in symptom/response form. That is, a symptom is given, and a check point response is provided for you.

#### Symptom 1

**System locks up on bootup with the GameWave 32 installed.**

#### Check

1. If a CD-ROM drive has been installed in the system, verify that the SWCD.SYS device line in the CONFIG.SYS file is loading before any other CD-ROM device drivers.
2. If the lock up occurs when loading the GW32.EXE

file, disable all sound settings by using GW32 /C. Enable each sound setting one at a time to identify which setting is causing the lock up. Port addresses and DMA conflicts will normally cause a lock up. IRQ conflicts will cause continuous noise from the speakers. When you have identified the conflict, change the address setting.

3. Check whether another peripheral in your system is using the same I/O address configured by Jumper J3 on the GameWave 32.

### Symptom 2

**No startup sounds when running the GW32.EXE program.**

#### Check

1. Verify that the external speaker is properly connected to the GameWave 32 stereo speaker jack.
2. Verify that the Startup Music is on and the volume is turned up on the GameWave 32.
3. Since the GameWave 32 uses the SoundBlaster interface to play the Startup Music, check for possible conflicts with the SoundBlaster interface settings.
4. Verify that the ORCHID.WAV file is in the GW32 directory. This file is limited to 8-bit resolution and 22KHz sample frequency (mono). If you have replaced the ORCHID.WAV file with another wave file, verify that it does not exceed these limits.

### Symptom 3

**I cannot access the CD-ROM drive.**

#### Check

1. If an Orchid CD-ROM drive is installed, verify



that the SWCD.SYS device line in the CONFIG.SYS file is loading before the CDD.SYS device line. If a Mitsumi or Sony compatible CD-ROM drive is installed, verify that the SWCD.SYS device line in the CONFIG.SYS file is loading before any other CD-ROM device drivers.

2. Verify that the MS-DOS file MSCDEX.EXE is copied into the GW32 directory or CD-ROM drive directory.
3. Verify that the path and syntax for each of the device driver lines (SWCD.SYS and CDD.SYS or other CD-ROM device driver), and the MSCDEX.EXE file is correct (refer to Section 2: Device Drivers).
4. If there is an LASTDRIVE statement in the CONFIG.SYS file, verify that the drive letter used is set to a letter after the CD-ROM drive (refer to your DOS manual for more information).
5. Verify that the colored stripe on ribbon cable is correctly installed on Pin 1 on both the GameWave 32 and the CD-ROM drive.

### Symptom 4

**My CD-ROM drive does not play CD Audio.**

#### Check

1. Verify that the audio cable used matches the pin-outs for the CD Audio connector. See Section 3 for the CD-ROM Audio Cable Connector pin assignments. Contact the Orchid Customer Service department for cable options.

### Symptom 5

**Wave files do not play correctly in Windows.**

### Check

1. Verify that the settings for the Sound Blaster driver in Windows match the settings configured with GW32.EXE. This can be done by opening the Driver icon from the Control Panel and double-clicking on the driver.

### Symptom 6

#### **MIDI files do not play correctly in Windows.**

### Check

1. Verify that the settings for the MPU-401 driver in Windows, match the settings configured with GW32.EXE. This can be done by opening the Driver icon from the Control Panel and double-clicking on the driver.

### Symptom 7

#### **Certain applications do not play sound.**

### Check

1. Verify that the GameWave 32 and the software application are configured for the same sound emulation modes (for example, SoundBlaster for digitized sound and either MT-32 or General MIDI for music).
2. Many software applications require a large amount of base memory, such as 640KB and are unable to operate if any drivers or TSR programs are installed. Try removing all unnecessary drivers and TSRs or load them in high memory (refer to your DOS user's manual for more information).
3. If you are using the MPU-401 interface, try the following addresses: Port 330 and IRQ 5. Some

software applications look specifically for this configuration.

### Symptom 8

**Certain applications do not play digitized sound, such as speech or sound effects.**

#### Check

1. Check for a conflict with the SoundBlaster interface configuration settings. Digitized sounds are played back through this interface.
2. Verify that the SET BLASTER statement is in the AUTOEXEC.BAT file. Some applications look specifically for this statement to set the SoundBlaster environment. Verify that the settings of the statement match the configuration for the GameWave 32 and the software application.
3. Verify that there is sufficient base memory to run the software application. If you are configuring the software application for SoundBlaster for digitized sound, and MIDI for Music, the software application may omit digitized sound if there is not enough base memory available.

### Symptom 9

**My joystick does not work when connected to the GameWave 32.**

#### Check

1. Verify that the Joystick Port in the GW32.EXE program is enabled.
2. Many I/O adapter cards have a built-in joystick/game port (even if they do not contain a 15-pin DB connector). The GameWave 32 has its own joystick port. Disable the joystick/game port on the I/O adapter card.

### Avoiding Address Conflicts

A conflict may occur if you have another card in your system using the same I/O, DMA or IRQ addresses as GameWave 32. Resolve the conflict by selecting another available address. When selecting a different address, please *note* the following information:

☞ A BUS mouse commonly uses I/O address 240H

☞ Network cards commonly use the following addresses:

IRQ 10 or 11

I/O 300H, 320H, 340H and 360H

☞ Other devices such as SCSI cards, hard disks and CD-ROM drives commonly use the following addresses:

IRQ 10, 11, 14 and 15

I/O 330H and 340H

☞ When you encounter an IRQ conflict, you will normally hear a continuous noise from the speakers. I/O and DMA conflicts normally lock up your system.

☞ GameWave 32 must use DMA Channel 1. If any other device is using DMA Channel 1, move it to another location.

### MIDI Usage

#### Compatibility with Roland MT-32

The Roland MT-32 synthesizer mode of GameWave 32 supports the system-exclusive messages (sysex) for reverb and voice assignment. It does not support sysex messages for partial synthesis. Therefore, games that attempt to create their own sound bank may experience sonic anomalies (weird sounds). Selecting General MIDI will correct this.

#### Roland Synthesizers

Some Roland synthesizers, most notably the D-50, send "all notes off" commands when all keys are released. This causes GameWave 32 sounds to play in a "staccato" fashion. Holding down one key while playing other notes will correct this.

#### External keyboard control of GameWave 32

If you wish to plug a MIDI keyboard into GameWave 32, you will need to purchase the joystick/MIDI cable adapter from Orchid. The Orchid GameWave 32 also supports "standard" joystick/MIDI cable sets, so if you have access to a Sound Blaster or Pro Audio Spectrum MIDI cable or compatible cable, it should work properly.

Due to the number mechanism used by various keyboard manufacturers, access to some of the GameWave 32 sounds may be restricted. The following are keyboards that may have sound access limitations:

- Korg M1 - The Korg M1 can access sounds 0 - 100. Switching to the ROM card addressing restarts the patch numbering from 0, not 101.
- Yamaha DX-7 - This synthesizer can access sounds 0 - 64 (internal and cartridge). If your DX-7 has the E! retrofit, then cycling through the upper banks will provide access to sounds 64 - 128.



*MIDI channel 1 is not active as a default in MT-32 mode. Your application (games or software) will activate it if required.*

## TECHNICAL INFORMATION

The features and specifications of GameWave 32 are covered in this section. Also included are specifications for the Joystick/MIDI port.

### GameWave 32 Technical Specifications

#### Features

Full compatibility with the following sound and multimedia standards:

- Sound Blaster
- AdLib
- General MIDI
- Roland MPU-401 interface
- Roland MT-32 sound module

#### Chipset

Analog Devices 20MHz ADSP-2115 DSP

#### Computers Supported:

ISA machines: IBM ATs—286, 386, 486,  
and compatibles

#### Card Size:

6" x 4.5"

#### Connectors:

DB-15 port for joystick/MIDI input/output  
3.5 mm stereo jack for amplified speaker output  
3.5 mm stereo jack for line out  
On-board interface for Sony CD-ROM drive  
On-board interface for Mitsumi CD-ROM drive

#### Temperature:

Operating: from 0 to 40 degrees C  
Storage: from -25 to 90 degrees C

#### Humidity:

Operating: from 15% to 90%  
Storage: from 0% to 90%

### Additional Features:

20 MIPS of Digital Signal Processing Power (DSP)

#### Stereo Digitized Audio Playback

- 8-bit and 16-bit sample modes
- Sampling Rate of :  
2KHz to 44.1KHz (mono)
- Hardware audio decompression ADPCM  
(ratios of 2:1, 3:1, and 4:1)

#### FM Synthesizer Emulations

- General MIDI Mode  
24 simultaneous voices
- MT-32 Mode  
Up to 32 simultaneous voices
- Yamaha OPL2 emulation  
FM stereo
- 11-voice Stereo Synthesizer

#### Sample Sounds

- 2 megabytes (1MBx16) wavetable samples,  
compressed and stored in two 512K (1MB)  
ROMS

#### Audio Amplifier

- Frequency Response: 20Hz to 22KHz

#### CD-ROM Kit

- Two built-in AT-Bus CD-ROM interfaces
- Optional Orchid dual-speed CD-ROM drive  
with 350ms access time and 307KB seconds  
transfer rate.

#### MIDI Kit

- Sound Blaster type joystick/MIDI cable

### Joystick Port/MIDI Interface

- Standard built-in (15-pin D-sub) connector
- Game I/O port for PC analog joystick
- Built-in interface for Sound Blaster MIDI cable with MIDI IN and MIDI OUT connectors
- MIDI time-stamp for Multimedia extension
- Sound Blaster MIDI compatible
- 64-byte FIFO buffer



### Address Settings and Pin Assignments

GameWave 32 uses an I/O port address for the Sound Blaster emulation mode. This address is hardware configured (see Section 1). All other address settings are software configured using the GINSTALL.EXE and GW32.EXE setup programs (see Section 2).

The information that follows lists all of the addresses available and pin assignments for GameWave 32:

#### CD-ROM Addresses

| I/O   | IRQ |
|-------|-----|
| 300   | 3   |
| 310   | 5   |
| 320   | 6   |
| 330   | 7   |
| 340   | * 9 |
| * 360 | 10  |
|       | 11  |

**Table A.1:** CD-ROM Addresses

#### Sound Blaster Mode Addresses

| I/O   | IRQ | DMA |
|-------|-----|-----|
| * 220 | 3   | * 1 |
| 240   | 5   |     |
|       | * 7 |     |

**Table A.2:** Sound Blaster Mode Addresses

\* *Default Setting*

MPU-401 Mode Addresses

| I/O   | IRQ |
|-------|-----|
| 300   | 3   |
| 320   | 4   |
| * 330 | * 5 |
|       | 7   |
|       | 9   |

Table A.3: MPU-401 Addresses

*\* Default Setting*

CD-ROM Audio Cable Connector

| Pin | Assignment    |
|-----|---------------|
| 1   | Ground        |
| 2   | Left Channel  |
| 3   | Ground        |
| 4   | Right Channel |

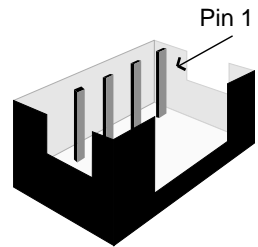

Table A.4: CD-ROM Audio Cable Pin-outs

### Joystick/MIDI Pin Assignments

The joystick port on GameWave 32 is identical to the standard PC Game Control adapter. The 15-pin D-sub connector is also used as the built-in MIDI interface. The pin-out assignments are as follows:

| Pin | Function | Pin | Function |
|-----|----------|-----|----------|
| 1   | +5V      | 9   | +5V      |
| 2   | A-1      | 10  | B-1      |
| 3   | A-X      | 11  | B-X      |
| 4   | GND      | 12  | MIDI-OUT |
| 5   | GND      | 13  | B-Y      |
| 6   | A-Y      | 14  | B-2      |
| 7   | A-2      | 15  | MIDI-IN  |
| 8   | +5V      |     |          |

**Table A.5:** Joystick/MIDI Pin Assignments



*If you want to use the joystick port on your PC, you can disable the joystick port on the GameWave 32 (refer to Section 2).*

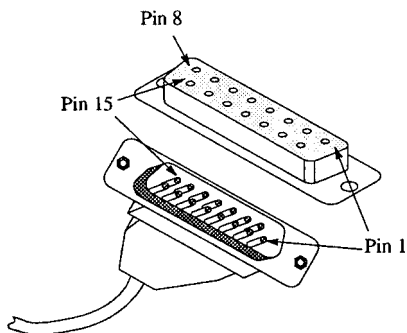

**Figure A.1:** Joystick/MIDI Pin-Outs

### GameWave 32 MIDI Port Specifications

The chart below shows the MIDI implementation for GameWave 32.

| <b>Function</b>    | <b>Setting</b>   | <b>Parameters</b>   |
|--------------------|--|---|
| Basic Channel      | Default Channels                                       | 1-16<br>1-16  |
| Mode               | Default Messages Altered                               | No<br>No<br>No  |
| Note Number        | True Voice   | 21-108  |
| Velocity           | Note ON<br>Note OFF                                    | Yes<br>Yes  |
| After Touch        | Key Channel  | Yes<br>Yes  |
| Pitch Blender      |  | Yes   |
| Control Change     |  | 1 Mod Wheel<br>4 Foot Pedal<br>7 Volume<br>10 Pan<br>64 Sustain |
| Program Change     | True Number  | 0-127   |
| System Exclusive   |  | Yes   |
| System Common      | Song Position<br>Song Select<br>Tune                   | No<br>No<br>No  |
| System Read Time   | Clocks<br>Commands                                     | No<br>No  |
| Auxiliary Messages | Local ON/OFF<br>All Notes OFF<br>Active Sense<br>Reset | No<br>Yes<br>No<br>Yes  |



## GAME HINTS

# A

GameWave 32 allows you to run numerous amazing games and entertainment software, which provides you with rich music, realistic voices and action. Depending on your needs, GameWave 32 can emulate Sound Blaster, AdLib, General MIDI synthesizer, Roland MT-32 sound module, and an OPL-type synthesizer. Following are suggestions for configuring the Sound Blaster, MT-32 and General MIDI emulation modes:

### Sound Blaster Mode

- Configure your software for Sound Blaster, Sound Blaster (old) or Adlib.
- Relative volumes between music and digitized sounds are typically controlled by software. Refer to your software user's manual.

### MT-32 Mode

- Set the GameWave configuration (GW32 /C) for Sound Blaster and MT32 emulation.
- Set the MPU-401 interface emulation for port address 330 and IRQ 5.
- Configure your software for Roland MT32 emulation or Sound Blaster + Roland MT32 emulation.

### General MIDI Mode

- Set the GameWave configuration (GW32 /C) for Sound Blaster and General MIDI emulation.
- Set the MPU-401 interface emulation for port address 330 and IRQ 5.

## *Appendix A: Game Hints*

---

- Configure your game software for General MIDI emulation or Sound Blaster + General MIDI emulation.
- The General MIDI configuration typically will produce the best music.

# B

## MIDI

This section gives you an overview of the MIDI specification, and provides a list of the Patches and Percussion sounds stored on GameWave 32.

### MIDI Overview

MIDI (Musical Instrument Digital Interface) is a serial communications protocol designed specifically for electronic music devices. MIDI (pronounced "mid-ee") has revolutionized the composition, recording, and performance processes by allowing many instruments to be centrally-controlled like one electronic orchestra. The MIDI Manufacturers Association (MMA) is responsible for the development and evolution of MIDI.

MIDI contains instructions controlling how and when devices like digital synthesizers produce sound. You can think of MIDI as a sort of Postscript for music. Postscript describes objects, rather than casting them into bitmapped form. MIDI describes the elements of the musical performance, rather than casting them into the bitstreams of digital audio.

### General MIDI

The GameWave 32 supports the General MIDI wave synthesis specification. General MIDI defines specific and predictable sounds for each of 128 program locations. This allows composers and producers to include program change commands in compositions that will configure the timbres appropriately for the tracks.



### GameWave 32 Sounds

These are the General MIDI and MT-32 Patches (sounds) that are stored on the GameWave 32. The GameWave 32 also contains over 40 percussion instruments on MIDI channel 10.

| Patch | MT-32 Sound      | General MIDI Sound    |
|-------|------------------|-----------------------|
| 1     | Acoustic Piano 1 | Acoustic Grand Piano  |
| 2     | Acoustic Piano 2 | Acoustic Bright Piano |
| 3     | Acoustic Piano 3 | Electric Grand Piano  |
| 4     | Electric Piano 1 | Honky Tonk Piano      |
| 5     | Electric Piano 2 | Fender Rhodes         |
| 6     | Electric Piano 3 | Chorused Piano        |
| 7     | Electric Piano 4 | Harpsichord           |
| 8     | Honky Tonk       | Clavinet              |
| 9     | Electric Organ 1 | Celesta               |
| 10    | Electric Organ 2 | Glockenspiel          |
| 11    | Electric Organ 3 | Music Box             |
| 12    | Electric Organ 4 | Vibraphone            |
| 13    | Pipe Organ 1     | Marimba               |
| 14    | Pipe Organ 2     | Xylophone             |
| 15    | Pipe Organ 3     | Tubular Bells         |
| 16    | Accordion        | Dulcimer              |
| 17    | Harpsichord 1    | Hammond Organ         |
| 18    | Harpsichord 2    | Percussive Organ      |
| 19    | Harpsichord 3    | Rock Organ            |
| 20    | Clavinet 1       | Church Organ          |
| 21    | Clavinet 2       | Reed Organ            |
| 22    | Clavinet 3       | Accordion             |
| 23    | Celesta 1        | Harmonica             |
| 24    | Celesta 2        | Tango Accordion       |
| 25    | Synth Brass 1    | Nylon Acoustic Guitar |
| 26    | Synth Brass 2    | Steel Acoustic Guitar |
| 27    | Synth Brass 3    | Jazz Electric Guitar  |
| 28    | Synth Brass 4    | Clean Electric Guitar |
| 29    | Synth Bass 1     | Muted Electric Guitar |
| 30    | Synth Bass 2     | Overdriven Guitar     |
| 31    | Synth Bass 3     | Distorted Guitar      |

|    |                   |                        |
|----|-------------------|------------------------|
| 32 | Synth Bass 4      | Guitar Harmonics       |
| 33 | Fantasy           | Acoustic Bass          |
| 34 | Harmony Piano     | Fingered Electric Bass |
| 35 | Chorale           | Picked Electric Bass   |
| 36 | Glasses           | Fretless Bass          |
| 37 | Soundtrack        | Slap Bass 1            |
| 38 | Atmosphere        | Slap Bass 2            |
| 39 | Warm Bell         | Synth Bass 1           |
| 40 | Funny Vox         | Synth Bass 2           |
| 41 | Echo Bell         | Violin                 |
| 42 | Ice Rain          | Viola                  |
| 43 | Oboe 2001         | Cello                  |
| 44 | Echo Pan          | Contrabass             |
| 45 | Doctor Solo       | Tremelo Strings        |
| 46 | School Daze       | Pizzicato Strings      |
| 47 | Bellsinger        | Orchestral Harp        |
| 48 | Square Wave       | Timpani                |
| 49 | String Section 1  | String Section 1       |
| 50 | String Section 2  | String Section 2       |
| 51 | String Section 3  | Synth Strings 1        |
| 52 | Pizzicato         | Synth String 2         |
| 53 | Violin 1          | Choir "Aahs"           |
| 54 | Violin 2          | Voice "Oohs"           |
| 55 | Cello 1           | Synth Voice            |
| 56 | Cello 2           | Orchestra Hit          |
| 57 | Contrabass        | Trumpet                |
| 58 | Harp 1            | Trombone               |
| 59 | Harp 2            | Tuba                   |
| 60 | Guitar 1          | Muted Trumpet          |
| 61 | Guitar 2          | French Horn            |
| 62 | Electric Guitar 1 | Brass Section          |
| 63 | Electric Guitar 2 | Synth Brass 1          |
| 64 | Sitar             | Synth Brass 2          |
| 65 | Acoustic Bass 1   | Soprano Sax            |
| 66 | Acoustic Bass 2   | Alto Sax               |
| 67 | Electric Bass 1   | Tenor Sax              |
| 68 | Electric Bass 2   | Baritone Sax           |
| 69 | Slap Bass 1       | Oboe                   |
| 70 | Slap Bass 2       | Basoon                 |

## Appendix B: MIDI

---

| Patch | MT-32 Sound     | General MIDI Sound |
|-------|-----------------|--------------------|
| 71    | Fretless 1      | English Horn       |
| 72    | Fretless 2      | Clarinet           |
| 73    | Flute 1         | Piccolo            |
| 74    | Flute 2         | Flute 81           |
| 75    | Piccolo 1       | Recorder           |
| 76    | Piccolo 2       | Pan Flute          |
| 77    | Recorder        | Bottle Blow        |
| 78    | Pan Pipes       | Shakuhachi         |
| 79    | Sax 1           | Whistle            |
| 80    | Sax 2           | Ocarina            |
| 81    | Sax 3           | Lead 1             |
| 82    | Sax 4           | Lead 2             |
| 83    | Clarinet 1      | Lead 3             |
| 84    | Clarinet 2      | Lead 4             |
| 85    | Oboe            | Lead 5             |
| 86    | English Horn    | Lead 6             |
| 87    | Bassoon         | Lead Fifths        |
| 88    | Harmonica       | Lead + Bass        |
| 89    | Trumpet 1       | New Age Pad        |
| 90    | Trumpet 2       | Warm Pad           |
| 91    | Trombone 1      | Polysynth Pad      |
| 92    | Trombone 2      | Choir Pad          |
| 93    | French Horn 1   | Bowed Pad          |
| 94    | French Horn 2   | Metallic Pad       |
| 95    | Tuba            | Halo Pad           |
| 96    | Brass Section 1 | Sweep Pad          |
| 97    | Brass Section 2 | Rain               |
| 98    | Vibe 1          | Soundtrack         |
| 99    | Vibe 2          | Crystal            |
| 100   | Synth Mallet    | Atmosphere         |
| 101   | Windbell        | Brightness         |
| 102   | Glockenshpiel   | Goblins            |

|     |                       |                   |
|-----|-----------------------|-------------------|
| 103 | Tube Bell             | Echoes            |
| 104 | Xylophone             | Sci-Fi            |
| 105 | Marimba               | Sitar             |
| 106 | Koto                  | Banjo             |
| 107 | Sho                   | Samisen           |
| 108 | Shakuhachi            | Koto              |
| 109 | Whistle 1             | Kalimba           |
| 110 | Whistle 2             | Bagpipe           |
| 111 | Bottleblow            | Fiddle            |
| 112 | Breathpipe            | Shanai            |
| 113 | Timpani               | Tinkle Bell       |
| 114 | Melodic Tom           | Agogo             |
| 115 | Deep Snare            | Steel Drums       |
| 116 | Electric Percussion 1 | Woodblock         |
| 117 | Electric Percussion 2 | Taiko Drum        |
| 118 | Taiko                 | Melodic Tom       |
| 119 | Taiko Rim             | Synth Drum        |
| 120 | Cymbal                | Reverse Cymbal    |
| 121 | Castanets             | Guitar Fret Noise |
| 122 | Triangle              | Breath Noise      |
| 123 | Orchestra Hit         | Seashore          |
| 124 | Telephone             | Bird Tweet        |
| 125 | Bird Tweet            | Telephone Ring    |
| 126 | One Note Jam          | Helicopter        |
| 127 | Water Bells           | Applause          |
| 128 | Jungle Tune           | Gunshot           |

### GameWave 32 Percussion Sounds

These are the Percussion sounds on the GameWave 32. These percussion instruments are accessed by sending data to MIDI channel 10.

| Key # | Keyboard Note | Sound              |
|-------|---------------|--------------------|
| 35    | B0            | Acoustic Bass Drum |
| 36    | C1            | Bass Drum 1        |
| 37    | C1+           | Side Stick         |
| 38    | D1            | Acoustic Snare     |
| 39    | D1+           | Hand Clap          |
| 40    | E1            | Electric Snare     |
| 41    | F1            | Low Floor Tom      |
| 42    | F1+           | Closed Hi-Hat      |
| 43    | G1            | High Floor Tom     |
| 44    | G1+           | Pedal Hi-Hat       |
| 45    | A1            | Low Tom            |
| 46    | A1+           | Open Hi-Hat        |
| 47    | B1            | Low-Mid Tom        |
| 48    | C2            | Hi-Mid Tom         |
| 49    | C2+           | Crash Cymbal 1     |
| 50    | D2            | High Tom           |
| 51    | D2+           | Ride Cymbal 1      |
| 52    | E2            | Chinese Cymbal     |
| 53    | F2            | Ride Bell          |
| 54    | F2+           | Tambourine         |
| 55    | G2            | Splash Cymbal      |
| 56    | G2+           | Cow Bell           |
| 57    | A2            | Crash Cymbal 2     |
| 58    | A2+           | Vibraslap          |
| 59    | B2            | Ride Cymbal 2      |
| 60    | C3            | Hi Bongo           |
| 61    | C3+           | Low Bongo          |
| 62    | D3            | Mute Hi Conga      |
| 63    | D3+           | Open Hi Conga      |
| 64    | E3            | Low Conga          |
| 65    | F3            | High Timbale       |
| 66    | F3+           | Low Timbale        |

|    |     |                 |
|----|-----|-----------------|
| 67 | G3  | High Agogo      |
| 68 | G3+ | Low Agogo       |
| 69 | A3  | Cabasa          |
| 70 | A3+ | Maracas         |
| 71 | B3  | Short Whistle   |
| 72 | C4  | Long Whistle    |
| 73 | C4+ | Short Guiro     |
| 74 | D4  | Long Guiro      |
| 75 | D4+ | Claves          |
| 76 | E4  | High Wood Block |
| 77 | F4  | Low Wood Block  |
| 78 | F4+ | Mute Cuica      |
| 79 | G4  | Open Cuica      |
| 80 | G4+ | Mute Triangle   |
| 81 | A4  | Open Triangle   |

*NOTE: C1 refers to the lowest C-key on a standard 5-octave keyboard. The + sign refers to a half-step (sharp).*



Appendix **GLOSSARY**

# C

## A

**.AUD** A sound file format developed by ESS Technology Inc. This format allows you to record and play back sound files at 16-bits per sample, set a higher sampling rate and select a level of compression.

**ADC** Analog-to-Digital Converter. A chip that takes analog sound information and transforms it into digital sound data that can be stored in the hard drive of your PC.

**ADI 1848 Codec** An implementation of the ADPCM compression standard. The 1848 Codec is an electronic circuit that converts voice or video into digital code (and vice versa) using techniques such as pulse code modulation and delta modulation.

**ADPCM** Adaptive Digital Pulse Code Modulation. A data compression routine that reduces the disk space used when sampling sound. Sampled sounds use a lot of disk space. For example, one minute of recorded voice annotation requires 660K of disk space. When using ADPCM the disk space is half the amount or 330K. ADPCM allows for 2:1, 3:1 and 4:1 compression ratios when sampling sound.

**audio** A range of frequencies within human hearing. Audio is processed in a computer by converting the analog signal into a digital code using various techniques, such as PCM.

**AUTOEXEC.BAT** A special DOS batch file that allows you to tailor the DOS operating system to your needs. It contains instructions and commands to set parameters to execute programs every time the



system boots up, and must be installed in the root directory of your boot drive.

### B

**backup** The process of transferring duplicate copies of files from one source to another in order to keep updated archives. This is especially helpful in order to save space on your hard drive, and to insure the safety of your data.

### C

**CD** Compact Disc. A high-density digital data storage medium that uses a 12cm (or smaller) reflective optical disc and is read by a laser system. CD is now commonly used as an abbreviation of CD-DA.

**CD-DA** Compact Disc-Digital Audio. CD-DA is the audio standard for compact disc. All the CDs sold in record shops are recorded to this standard—44.1KHZ and 16-bit PCM.

**CDI** Compact Disc-Interactive. An interactive system that combines live video, still images, text and digital graphics on the same storage media.

**CD-ROM** Compact Disc Read Only Memory. A compact disc format used to hold text, graphics and hi-fi stereo sound. CD-ROM players can play music, entertainment and other CDs, and usually have headphone and amplifier jacks.

**CD-ROM AT-BUS** A CD-ROM drive that uses a proprietary interface that is very similar to the AT BUS interface.

**CD-ROM/XA** Compact Disc Read Only Memory/Extended Architecture. A combination of CD-ROM and CD-DA, CD-ROM/XA provides normal

CD-ROM capabilities plus ADPCM audio from the CD-I format. CD-ROM/XA allows for the interleaving of sound and picture data for animation and sound synchronization.

**CONFIG.SYS** The file that contains specific configuration instructions for DOS during boot up. You can customize this file to tell DOS about your computer hardware setup.

## **D**

**DAC** Digital-to-Analog Converter. A converter used to turn digital information into sound waves.

**data compression** Translation of data to a form to take up less storage. Text files can be compressed the most. Some graphics files leave little room for compaction; others compress well. Sound files compress each time the ratio increases, however, the sound quality decreases.

**DSP** Digital Signal Processing. A category of techniques that analyze signals from a wide range of sources, such as voice and sound. It converts the signals into digital data and analyzes it using various algorithms. The DSP chip on the GameWave 32 card is programmable to allow control of the sound generation.

**dynamic filtering** Helps eliminate electronic emissions from the PC that can show up as noise in the sound card output.

**DMA** Direct Memory Access. A method of transporting data between memory and peripherals, which frees the CPU to perform other tasks.

**DOS** Disk Operating System. The link between software and hardware where a collection of pro-

grams and command-line processors control the use of the entire system.

### F

**FM synthesis** The artificial method of reproducing a particular sound by combining (as close as possible) various waveforms to match those that a voice or instrument actually produces.

### G

**General MIDI Mode** Defines specific and predictable sounds (instruments) for each of 128 program locations. Although MIDI is standardized, General MIDI Mode standardizes a palette of sound and their program locations.

**Gig** A performance. Typically used by musician types to describe their next, current, or past employment ventures.

### M

**MIDI** Musical Instrument Digital Interface. Standard protocol for the interchange of musical information between musical instruments, synthesizers and sound cards. MIDI is commonly used to synchronize notes produced on several synthesizers. Its control messages can orchestrate a series of synthesizers, each playing a part of the musical score.

**MIDI synthesizer** Allows an external MIDI device such as a musical keyboard to connect to the sound card, compose music and store it on a PC.

**mixer** A combination of hardware and software that allows you to separately control the individual volumes of each audio source, such as a CD-ROM and MIDI.

**modem** Modulator-Demodulator. A device that allows the computer to transmit and receive data through telephone lines.

**MPC** Multimedia PC. An equipment standards specification (minimum performance) for personal computers. It was created by the Multimedia PC Marketing Council, and currently consists of two standards—MPC Level 1 and MPC Level 2. The GameWave 32 provides support for both standards.

**multimedia** Communicating information in digital and electronic form. Includes the use of text, audio, graphics, animated graphics and full-motion video.

**multisession Photo CD** A format that allows you to view photos stored on a CD-ROM.

**MT32** Multi-Timbral 32. A Roland sound standard used by most game developers to score original music. All the sound effects are stored on the sound tracks.

## O

**Object Linking and Embedding (OLE)** A protocol designed by Microsoft for copying and sharing information between applications.

## P

**PCM** Pulse Code Modulation. The process of changing analog sound waves into digital information and back again.

**Photo CD** *See multisession Photo CD.*

**polyphonic** An option on an audio synthesis device to support more than one voice simultaneously.

### S

**sampling** Recording and playing back sounds. In digitizing operations, the conversion of real-world signals or movements at regular intervals into digital code.

**sampling rate** In digitizing operations, the frequency with which samples are taken and converted. The higher the sampling rate, the truer the representation of the sound being recorded.

**sampled sound** Recording a particular instrument to create a true model of the waveforms generated by that instrument. This generally produces a more realistic synthesized sound.

**sequencing software** Software used to handle entire multi-instrument compositions, not just single notes.

**Sound Blaster** The Creative Labs sound standard that is mostly used for business audio and business applications.

### V

**voice annotation** A verbal note or comment that you add to spreadsheets or other documents.

### W

**.WAV** The Microsoft Windows 3.1 format to record and play back audio files.

**waveform** Pattern of a particular sound wave or other electronic signal in analog form.

**wavetable** A recording of authentic instrument recordings stored in ROM.

---

## Limitation of Liability

Neither Orchid Technology nor anyone else who has been involved in the creation, production, or delivery of this product shall be liable for any direct, indirect, special, punitive, consequential, or incidental damages (including, without limitation, damages for loss of business profits, business interruption, loss of business information, and the like) arising out of the use of or inability to use this product, even if Orchid Technology has been advised of the possibility of such damages.

Because some states do not allow the exclusion of liability for consequential or incidental damages, the above limitation may not apply to you. In any event, Orchid Technology's liability arising in any manner in connection with this product, whether based in contract, product liability, or tort, shall not exceed the purchase price of the product.

## FCC NOTICE

FCC# DDS7EF0893-93-GWA

GameWave 32  
Certified compliant with FCC Class B limits, part 15

To meet FCC requirements, shielded cables are required  
to connect the unit to a Class B certified device

“This device complies with Part 15 of the FCC Rules. Operation is subject to the following two conditions: (1) this device may not cause harmful interference, and (2) this device must accept any interference received, including interference that may cause undesired operation.”

This equipment generates and uses radio frequency energy and, if not installed and used properly in strict accordance with the manufacturer’s instructions, may cause interference to radio or television reception.

This device has been tested and found to comply with the limits for a Class B computing device in accordance with the specifications in Subpart J of Part 15 of FCC Rules, which are designed to provide reasonable protection against such interference in a residential installation. Only equipment (computer input/output devices, terminals, printers, etc.) certified to comply with the Class B limits may be attached to this product.

If this equipment causes interference to radio or television reception, which can be determined by turning the equipment off and on, the user is encouraged to try and correct the interference by one or more of the following measures:

1. Reorient the receiving antenna.
2. Relocate the computer with respect to the receiver.
3. Move the computer away from the receiver.
4. Plug the computer into an outlet which resides on a different circuit breaker than the receiver.
5. If necessary, consult your dealer, or an experienced radio or television technician for additional suggestions.

You may find the booklet **How To Identify and Resolve Radio-TV Interference Problems** helpful. It was prepared by the Federal Communications Commission and is available from the U.S. Government Printing Office, Washington, DC 20402. Refer to stock number: 004-000-00345-4.

Orchid Technology is not responsible for any radio or TV interference caused by unauthorized modifications to this equipment. It is the responsibility of the user to correct such interference.

Operation with non-certified equipment is likely to result in interference to radio and TV reception. The user must use shielded interface cables in order to maintain the product within FCC compliance.

## INDEX

---

---

### A

- Address Settings - 46
- Address Conflicts - 41

---

---

### C

- CD-ROM DISC Handling - 21
- CD-ROM Drive
  - Address Settings - 46
  - Interfaces - 10
  - Operation - 18
- Changing the Address Settings - 33
- Commands
  - DOS - 33
- Configuring
  - GameWave 32 - 28
  - Sound Standards - 27, 29
- Connecting External Devices - 16

---

---

### D

- DB-15 port for joystick/MIDI input - 15, 48
- Device Drivers - 31
- Diagram (GameWave 32) - 10
- DOS Command Line Options - 33

---

---

### E

- External Devices - 16



---

---

**G**

- Game Hints - 51
- Game Port - 10, 15
- Game Port/MIDI port pin assignments - 48
- Glossary - 61
- GW32.EXE Utility - 33

---

---

**H**

- Help
  - Avoiding address conflicts - 41
  - CompuServe - 35
  - MIDI usage - 42
  - Troubleshooting - 36

---

---

**I**

- Installation
  - CD-ROM Drive - 17
  - Device Drivers - 31
  - Installing the GameWave 32 - 14
  - Other CD-ROM Drives - 21
  - Preparing your Computer - 11
  - Preparing your GameWave 32 - 11

---

---

**J**

- Joystick port - 10, 15
- Jumpers
  - Locations of jumpers - 10
- Jumper Settings
  - Jumpers J3 (I/O Address) - 12
  - Jumper J12 (Wavetable) - 12

---

---

**L**

Line Out jack - 10, 15

---

---

**M**

**MIDI**

Cable - 24

General MIDI - 53

Interface - 10, 15

Overview - 53

Specifications - 49

Usage - 42

---

---

**S**

GameWave 32 Diagram - 10

**Sound**

Configuration - 28

Driver installation - 28

Standards - 29

**Sounds**

General MIDI - 53

MT-32 - 54

Percussion - 58

Speaker output jack - 10, 15

Summary of jumper settings - 11

---

---

**T**

Technical Help - 35

Technical Information - 43

Technical Specifications - 43

Troubleshooting - 36



Orchid Technology  
Fremont, California

Orchid France, S.A.R.L.  
Colombes, France

Orchid Technology GmbH  
Meerbusch, Germany

Orchid (Europe) Limited  
Basingstoke, U.K.