

*2nd head goes here - electronics identical*

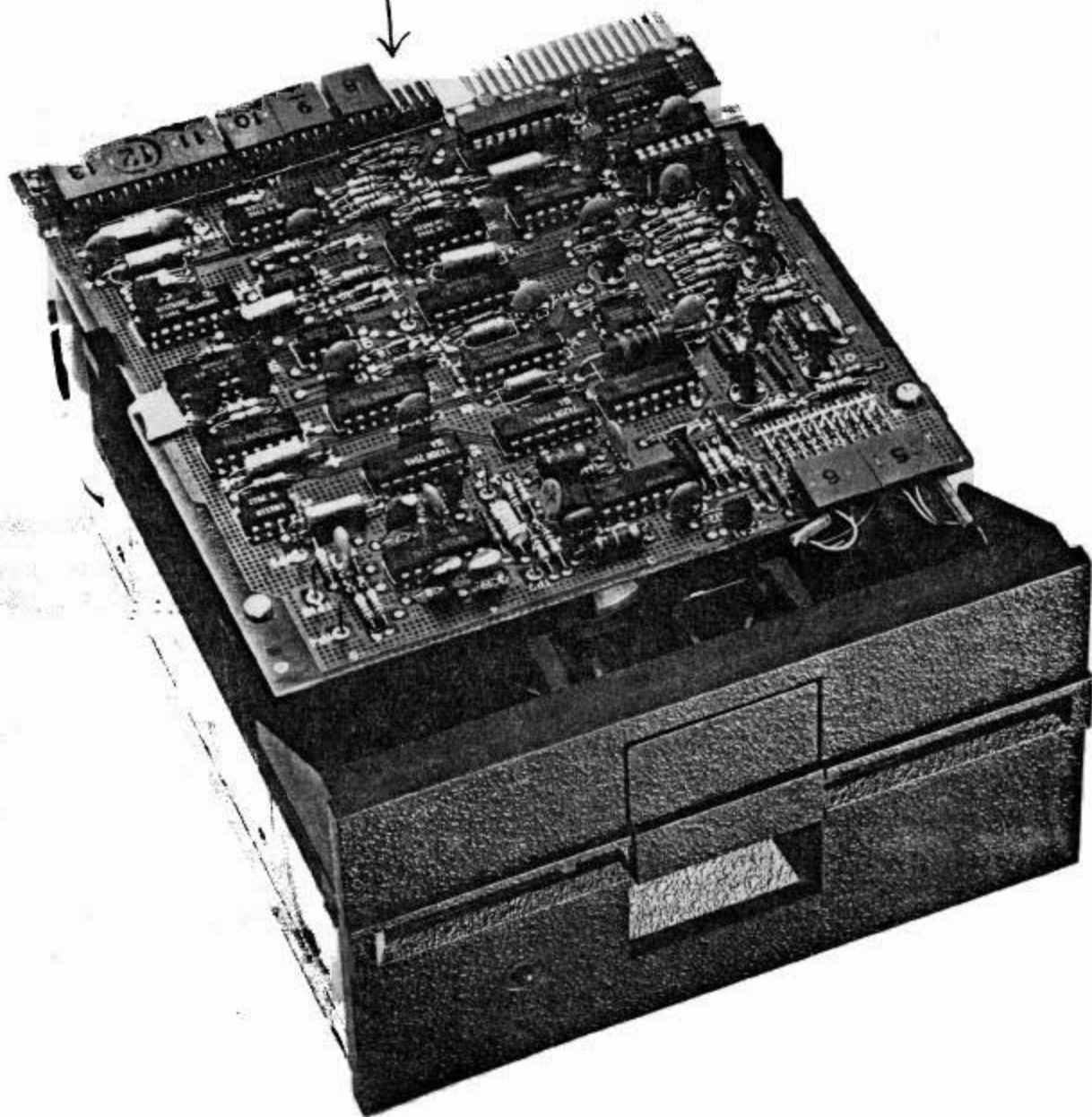

**PRODUCT SPECIFICATION  
SINGLE-SIDED AND DOUBLE-SIDED  
TM100 SERIES, 5¼-INCH FLEXIBLE DISK DRIVES  
48, 96, AND 100 TRACKS PER INCH**

## 1. INTRODUCTION

Tandon Corporation's TM100 series of drives are full feature, 5¼-inch flexible disk drives. They are compact data storage devices that use an IBM-formatted Industry Standard five and one-quarter (5-¼) inch diskette.

Model Number TM100-1 and TM100-2 drives each have 48 tracks per inch. The TM100-1 is a single-sided recording device, while the TM100-2 is a double-sided recording device. Model Number TM100-3 and TM100-4 drives each have 96 tracks per inch. Model Number TM100-3M and TM100-4M drives each have 100 tracks per inch. The TM100-3 and TM100-3M are single-sided recording devices, while the TM100-4 and TM100-4M are double-sided recording devices.

The TM100 drives are capable of reading and writing in single-density format on a diskette, using a proprietary read/write head patented by Tandon. This drive has a double density capability when a Modified Frequency Modulation (MFM) or other appropriate recording technique is used. The encoding and decoding of the data is done by the user's controller. Model Numbers TM100-2, -4 and -4M double data storage capabilities by using both sides of the diskette.

Track positioning is accomplished by using a metal band driven by a stepper motor that provides a five (5) millisecond track-to-track step interval for the TM100-1 and -2 drives, and a three (3) millisecond track-to-track step interval for the TM100-3, -3M, and -4M drives.

### 1.1 SCOPE OF THE DOCUMENT

This product specification contains the major features, specifications, mounting, and power requirements, and interface description and typical electrical interface and timing characteristics of the TM100 series of drives. The contents of this document may not be copied or sold without the written permission of Tandon Corporation.

These specifications are subject to change without notice.

## 2. MAJOR FEATURES

### 2.1 WRITE PROTECT (STANDARD)

When a write protected diskette is inserted in the drive, the write electronics are disabled.

### 2.2 DAISY CHAIN CAPABILITY (STANDARD)

The drive provides the address selection and gating functions necessary to daisy chain a maximum of four (4) units at the user's option. The last drive on the daisy chain terminates the interface. The terminations are accomplished by a resistor array plugged into a DIP socket.

### 2.3 INTERNAL TRIM ERASE (STANDARD)

The drive provides the control signals necessary for proper trim erasure of data.

2.4 **INDUSTRY STANDARD INTERFACE COMPATIBILITY**

The drive is compatible with controllers that use the industry standard interface.

2.5 **ACTIVITY INDICATOR (STANDARD)**

An activity indicator, located on the front panel, is automatically illuminated when the drive is selected.

3. **PERFORMANCE SPECIFICATIONS**

3.1 **HEADS AND HEAD WEAR GUARANTEE**

Heads: Single- or double-sided recording heads, Tandon patented design.

Head Wear Guarantee: 20,000 media contact hours

3.2 **MEDIA AND MEDIA LIFE**

Media: 133.4 millimeter (5.25-inch) Industry Standard diskette

Media Life (For Reference Only):  $4 \times 10^6$  passes per track

3.3 **CAPACITY**

Tracks Per Inch:

48 TPI, TM100-1 and TM100-2

96 TPI, TM100-3 and TM100-4

100 TPI, TM100-3M and TM100-4M

Tracks Per Drive:

40 for TM100-1

80 for TM100-2, TM100-3, and TM100-3M

160 for TM100-4 and TM100-4M, 80 per side

Spacing:

0.529 millimeters (20.8 milinches), TM100-1 and -2

0.265 millimeters (10.4 milinches), TM100-3, -3M, -4 and -4M

### 3.4 ACCESS TIMES

#### Track-To-Track:

5 milliseconds, TM100-1 and -2

3 milliseconds, TM100-3, -3M, -4, and -4M

Head Settling Time: 15 milliseconds

Average Access Time, including head settling time:

75 milliseconds, TM100-1 and -2

90 milliseconds, TM100-3, -3M, -4, and -4M

### 3.5 DISK ROTATIONAL SPEED

Motor Start Time: 250 milliseconds

Average Rotational Latency: 100 milliseconds

Motor Stop Time: 150 milliseconds maximum

Disk Rotational Speed: 300 RPM  $\pm$ 1.5 percent

Instantaneous Speed Variation (ISV):  $\pm$ 3 percent

### 3.6 RECORDING CAPACITY AND METHOD

#### Flux Reversals Per Inch, Inside Track:

5535 FRPI, Side 0, TM100-1 and -2

5576 FRPI, Side 0, TM100-3, -3M, -4, and -4M

5877 FRPI, Side 1, TM100-2, -4, and -4M

Transfer Rates: 250,000 BPS

FM: 125,000 BPS

MFM: 250,000 BPS

#### Unformatted Recording Capacity:

2.0 megabits per diskette, unformatted double density, TM100-1

4.0 megabits per diskette, unformatted double density, TM100-2, -3, and -3M

8.0 megabits per diskette, unformatted double density, TM100-4 and -4M

### 3.7 **ELECTROMAGNETIC CHARACTERISTICS**

The drives are designed to minimize electrical interference that is generated internally and propagated through space or on associated conductors.

## 4. **RELIABILITY**

### 4.1 **ERROR RATES**

Error rates are exclusive of external sources, e.g.: electronics, defective diskettes, and contaminated diskettes.

One recoverable error in  $10^9$  bits read.

One nonrecoverable error in  $10^{12}$  bits read.

One seek error in  $10^6$  seeks.

### 4.2 **MEAN TIME BETWEEN FAILURES**

MTBF: 8000 power-on hours

### 4.3 **MEAN TIME TO REPAIR**

MTR: 30 minutes

### 4.4 **PERIODIC MAINTENANCE**

Periodic maintenance is not required.

## 5. **ENVIRONMENTAL SPECIFICATIONS**

The drive meets its operational specifications under the environmental conditions listed below.

### 5.1 **TEMPERATURE**

Operating Temperature:  $16^{\circ}\text{C}$  to  $44^{\circ}\text{C}$  ( $50^{\circ}\text{F}$  to  $112^{\circ}\text{F}$ )

Storage Temperature:  $-40^{\circ}\text{C}$  to  $71^{\circ}\text{C}$  ( $-40^{\circ}\text{F}$  to  $160^{\circ}\text{F}$ )

### 5.2 **RELATIVE HUMIDITY**

Noncondensing Operating Humidity: 20-to-80 percent

Noncondensing Nonoperating Humidity: 5-to-95 percent

### 5.3 **SHIPMENT**

When prepared for shipment by Tandon, the drive meets the requirements of NSTA Pre-Shipment Test Procedure Project 1A.

5.4 ALTITUDE

304.8 meters (500 feet) below sea level to 15,240 meters (50,000 feet) above sea level, operating or nonoperating.

6. MECHANICAL SPECIFICATIONS AND MOUNTING

6.1 MECHANICAL SPECIFICATIONS

Height: 85.85 millimeters (3.25 inches)

Width: 146.1 millimeters (5.75 inches)

Length: 203.2 millimeters (8.0 inches), excluding front panel

Weight: 2.04 kilograms (4.5 pounds)

6.2 MOUNTING

The drive may be mounted upright, horizontally or vertically. When mounted horizontally, the large circuit board must be on top.

Four 8-32 tapped mounting holes are provided on the bottom of the drive, as are two 8-32 tapped mounting holes on each side of it for attachment to user-supplied mounting brackets (see Figure 1). When mounted in any of the above positions, only two holes per side are required to securely hold the drive in place.

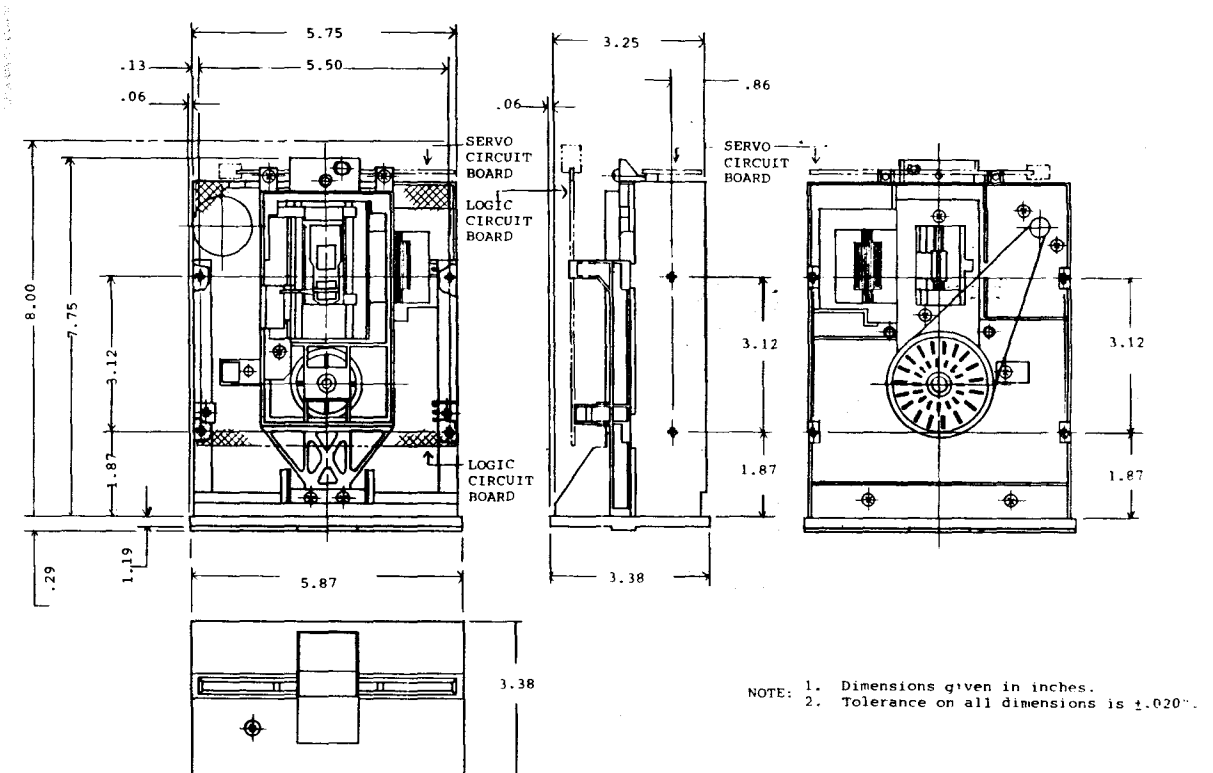

Figure 1  
Disk Drive Outline Drawing

## 7. POWER REQUIREMENTS

### 7.1 D. C. POWER SEQUENCING

A maximum of one (1) second is required from the time power is applied to the drive until the time at which a command can be accepted.

### 7.2 PRIMARY POWER

+12 volts D. C. Power: +12 volts  $\pm$  0.6 volt at 900 milliamperes, average maximum

+5 volts D. C. Power: +5 volts  $\pm$  0.25 volt at 600 milliamperes, average maximum, with less than 100 millivolts peak-to-peak ripple

### 7.3 D. C. CONNECTOR

D. C. power is supplied to this drive through a four-pin AMP connector, Part Number 350211-1; connected to the circuit board, J3. The mating connector, not supplied, is AMP Part Number 1-480424-0, using AMP contact Part Number 606191-1. Pin assignments are found in Table 1.

The chassis should be connected to earth ground to ensure proper operation.

Table 1

D. C. Power Connector Pin Assignments, P3, J3

Pin	Supply Voltage
1	+12 volts D. C.
2	12 volts return
3	5 volts return
4	+5 volts D. C.
Pin	Signal
Ground lug 3/16" quick disconnect.	Chassis ground from controller.

## 8. INTERFACE DESCRIPTION

The input/output is an industry-compatible interface. The connector, P1/J1, is a 34-pin edge card connector, J1. The mating connector, P1, not supplied, may be a Scotch-Flex Ribbon connecting 3M Part Number 3463-001 or an AMP Part Number 583717-5, using contacts Part Number 1-583616-1 for twisted pair. Signal connector pin assignments can be found in Table 2.

**Table 2**  
**Drive Interface Lines and Pin Connectors**

<b>Input Control Lines: Controller-To-Disk Drive</b>		
<b>Ground</b>	<b>Pin</b>	<b>Signal</b>
1	2	Connector Clamp
3	4	Spare
5	6	Drive Select 3
9	10	Drive Select 0
11	12	Drive Select 1
13	14	Drive Select 2
15	16	Motor On
17	18	Direction Select
19	20	Step
21	22	Composite Write Data
23	24	Write Enable
31	32	Side Select
<b>Output Status Lines: Disk Drive-To-Controller</b>		
<b>Ground</b>	<b>Pin</b>	<b>Signal</b>
7	8	Index/Sector
25	26	Track 0
27	28	Write Protected
29	30	Composite Read Data
33	34	Connector Clamp

**8.1 INPUT CONTROL LINES**

**8.1.1 DRIVE SELECT LINES**

The Drive Select lines provide a means of selecting and deselecting a disk drive. These four lines select one of the four drives attached to the controller.

When the signal logic level is true (low), the drive electronics are activated, the head is loaded, and the drive is conditioned to respond to Step or Read/Write commands. When the signal line logic level is false (high), the input control lines and output status lines are disabled.

A Drive Select line must remain stable in the true (low) state until a Step or Read/Write command is completed.



The drive address is determined by a select shunt on the Logic circuit board. Drive Select lines 0 through 3 provide a means of daisy chaining a maximum of four (4) drives to a controller. Only one can be true (low) at a time. An undefined operation will result if two or more drives are assigned the same address or if two or more Drive Select lines are in the true (low) state simultaneously.

#### 8.1.2 MOTOR ON

When this signal is true (low), the drive motor accelerates to its nominal speed of 300 RPM, and stabilizes at this speed in less than 250 milliseconds. When the signal line logic level goes false (high), the drive decelerates to a stop in less than 150 milliseconds. This signal is not gated with select.

For Model Numbers TM100-3, -3M, -4, and -4M, the motor activates momentarily when the front door (latch) is closed.

#### 8.1.3 DIRECTION SELECT AND STEP LINES (TWO LINES)

When the drive is selected, a true (low) pulse with a time duration greater than 200 nanoseconds initiates the access motion. The direction of motion is determined by the logic state of the Direction Select line when a step pulse is issued. The motion is toward the center of the disk if the Direction Select line is in the true (low) state when a step pulse is issued. The direction of motion is away from the center of the disk if the Direction Select line is in the false (high) state when a step pulse is issued.

To ensure proper positioning, the Direction Select line should be stable at least 100 nanoseconds prior to issuing a corresponding step pulse, and remain true (low) 100 nanoseconds after it.

The access motion is initiated on the trailing edge of the step pulse. The time period between consecutive trailing edges of step pulses should be at least five (5) milliseconds for all other TM100 series drives.

The drive electronics ignore step pulses when one of three conditions exists:

1. The write enable is true (low).
2. The direction select is false (high) and the head is positioned at Track 0.
3. The drive is not selected.

#### 8.1.4 COMPOSITE WRITE DATA

When the drive is selected, this interface line provides the bit serial composite write data pulses that control the switching of the write current in the selected head. The write electronics must be conditioned for writing by the Write Enable line.

For each high-to-low transition on the Composite Write Data line, a flux change is produced at the write head gap. This causes a flux change to be recorded on the media.

When a double-frequency type encoding technique is used in which data and clock form the combined Write Data signal, it is recommended that the repetition of the high-to-low transitions, when writing all zeros, be equal to the nominal data-rate  $\pm 0.1$  percent, and that the repetition of the high-to-low transitions, when writing all ones, be equal to twice the nominal data rate  $\pm 0.1$  percent.

#### 8.1.5 WRITE ENABLE

When this signal is true (low), the write electronics are prepared for writing data and the read electronics are disabled. This signal turns on write current in the selected read/write head. Data is written under the control of the Composite Write Data and Side Select input lines. When the Write Enable line is false (high), all write electronics are disabled.

When a write-protected diskette is installed in a drive, the write electronics are disabled irrespective of the state of the Write Enable or Side Select lines.

#### 8.1.6 SIDE SELECT, TM100-2, -4, AND -4M

The Side Select interface line defines which side of a two-sided diskette is used for information transfer.

A false (high) level on this line selects the read/write head on Side Zero of the diskette. A true (low) level on this line selects the read/write head on Side One of the diskette.

### 8.2 OUTPUT STATUS LINES

#### 8.2.1 INDEX/SECTOR

The Index/Sector signal is a composite of the index pulse and sector signals.

An index is provided once every revolution, 200 milliseconds nominal, to indicate the beginning of a track to the controller. The leading edge of this signal must always be used to ensure timing accuracy. The Index/Sector line remains in the true (low) state for the duration of the index/sector pulse, which is nominally 3.5 milliseconds.

The Sector signal portion appears only when using hard sectored diskettes.

#### 8.2.2 TRACK 0

When the drive is selected, the Track 0 interface signal, if true, indicates to the controller that the read/write head is positioned on Track 0. This signal remains true (low) until the head is moved away from Track 0.

#### 8.2.3 WRITE PROTECTED

When the Write Protected line goes true (low), the diskette is write protected and the write electronics are disabled. It is recommended that the controller not issue a Write command when the Write Protect signal is true (low).

When the Write Protected line is false (high), both write electronics and write operations are enabled.

### 8.2.4 COMPOSITE READ DATA

This interface line transmits the readback data to the controller when the drive is selected. It provides a pulse for each flux transition detected and recorded on the diskette. The Composite Read Data output line goes true (low) for a duration of  $1 \pm .25$  microseconds for each flux change recorded on the diskette.

The leading edge of the Composite Read Data output pulse represents the true position of the flux transitions on the diskette's surface.

## 9. TYPICAL INTERFACE CHARACTERISTICS

Lines between the controller and the drive have the following characteristics:

$$\text{True} = V_{\text{out}} + 0.4 \text{ volt maximum at } I_{\text{out}} = 48 \text{ milliamperes, maximum}$$

$$\text{False} = V_{\text{out}} + 2.4 \text{ volts minimum open collector at } I_{\text{out}} = 250 \text{ milliamperes, maximum}$$

Figure 2 contains the characteristics of the electrical interface. Figure 3 contains the control and data timing requirements of all drives.

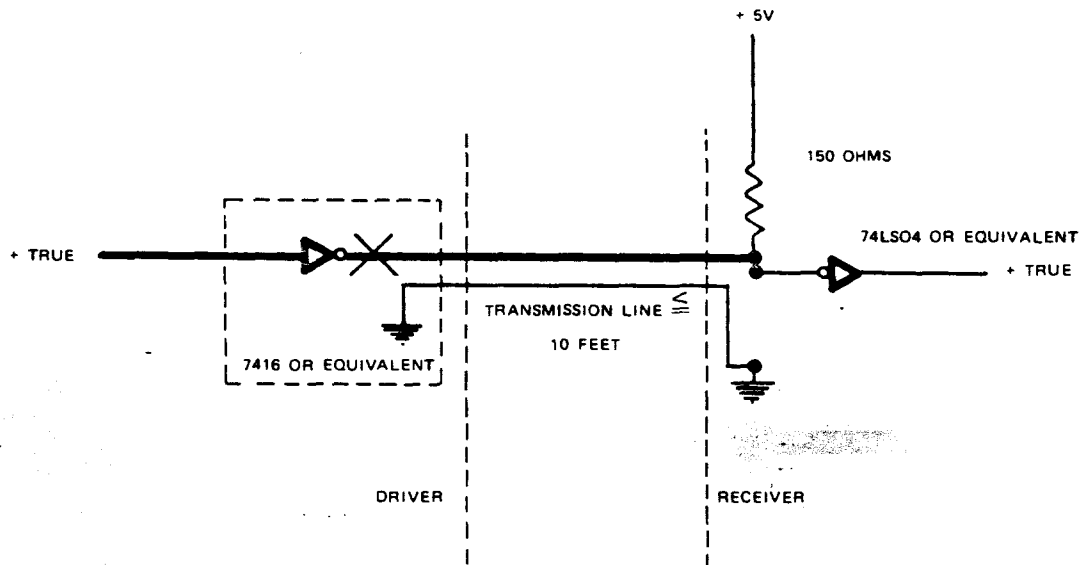

Figure 2  
Electrical Interface Characteristics

## 10. DEVICE ADDRESSING AND OPTION PATCHING

The drive address and option patching is determined by the programmable shunt socket 1E located on the Logic circuit board (see Figure 4). The DS0 through DS3 jumpers determine the drive address. The MX jumper is only used in single drive systems and the HS, HM jumpers are patchable options for Tandon drives that are equipped with a head load solenoid.

The program shunt is AMP Part Number 435705 for TM100-1 and -2, and Part Number 535704-7 for TM100-3 and -4. The shunt positions can be cut using AMP's tool, Part Number 435705. The shunt is installed in a DIP socket and, at the user's option, can be removed and replaced by a DIP switch. In addition, the user may choose to have program shunts preprogrammed and color coded by AMP.

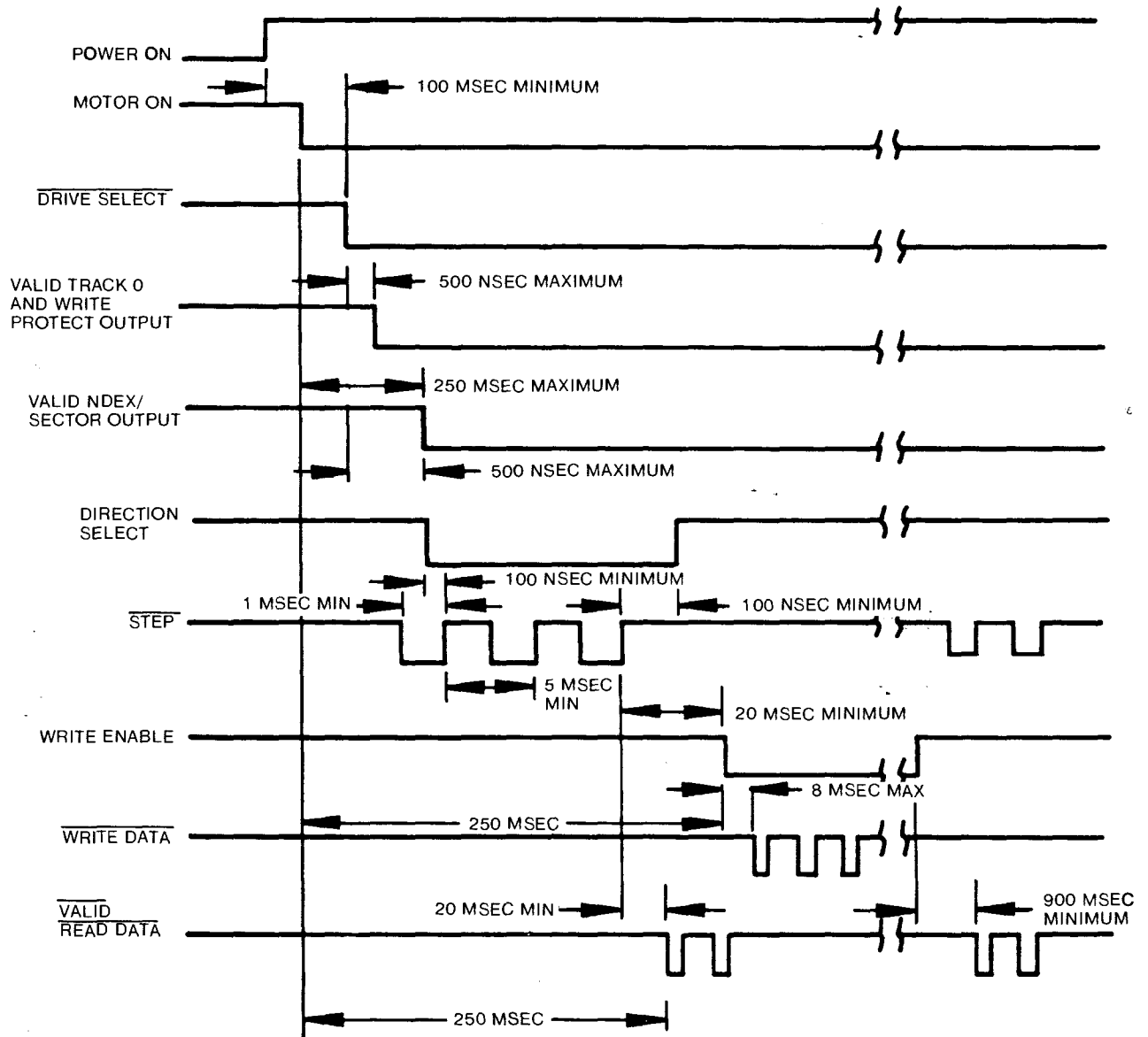

Figure 3  
Control and Data Timing Requirements

## 10.1 DS0 THROUGH DS3 JUMPERS

When daisy chaining two or more drives to a controller, the DS jumpers patch the drive select control signal to enable the logic of the proper drive. Normally, all the shunt 1E jumpers would be cut, except for the DS jumper that addresses each individual drive in the daisy chain, unless the drive is equipped with a head load solenoid. The terminator pack located on socket 2F of the Logic circuit board (see Figure 4) should be installed in the last drive of the daisy chain.

## 10.2 MX JUMPER

The MX jumper is used only in single drive systems when the user requires the drive logics to be enabled at all times. If the drive is not selected through the DS jumper, and the MX jumper is not cut, the drive logics are enabled but the front panel L. E. D. is not on. Note that the MX jumper must be cut in a multiple drive system.

## 10.3 HS AND HM JUMPERS

Normally, Tandon drives have no head load solenoid. Hence, the HS and HM jumpers are normally cut. In no case should both of these jumpers be installed since this would allow interaction between the Select signal and the Motor On signal. However, if the optional head load solenoid is installed, the HS jumper enables the solenoid when the unit is selected. When the Motor On signal to the drive is true, the HM jumper enables the solenoid.

## 10.4 POWER SAVE OPTION

As shipped from the factory, the drive is configured with a jumper at R49 (0 ohm resistor) for the TM100-3 and -4 drives, and at R50 (0 ohm resistor) for the TM100-1 and -2 drives. R49 or R50 maintains 200 milliamperes of current to the stepper motor whether or not the drive is selected. Maintaining power to this motor prevents the head carriage from moving when the drive is not selected. The jumper at R49 or R50 may be moved to position R50 or R51, which removes the power to the stepper motor when the drive is not selected, for a savings of approximately 3.8 watts per drive. When R50 or R51 is used, the user must ensure the track location when the drive is reselected.

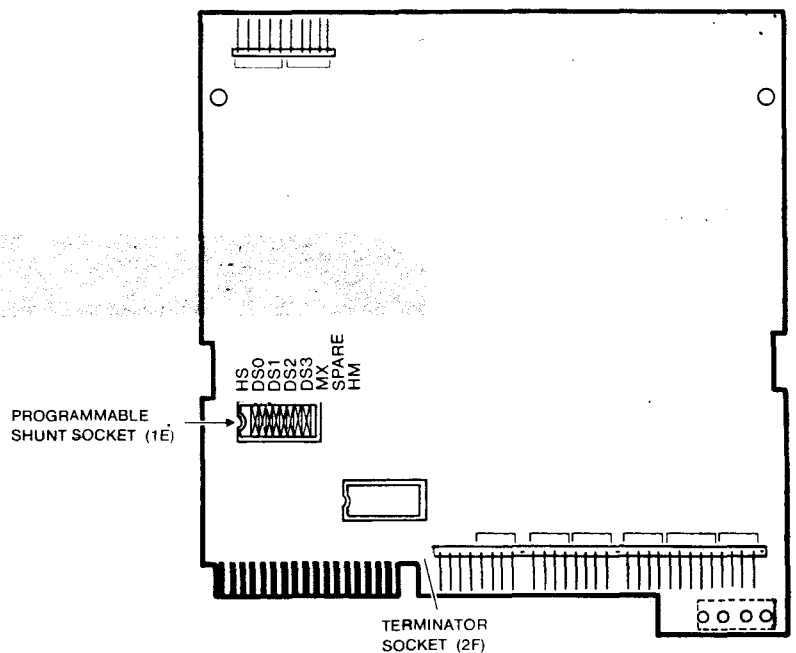

Logic Circuit Board

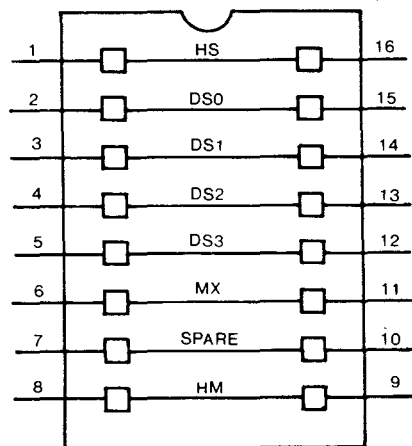

Programmable Shunt Socket 1E

Figure 4  
Logic Board With Programmable Shunt Socket 1E

## TANDON'S MAJOR LOCATIONS

Corporate Offices  
20320 Prairie Street  
Chatsworth, CA 91311  
Tel. No.: (213) 993-6644  
Twx No.: 910-493-5965

Eichenstrasse 59  
D-6230 Frankfurt/Main 83  
West Germany  
Tel. No.: 0611-392081  
Telex No.: 841-411547