

---

# **Chapter 1**

## **Hardware Overview**

---

This page intentionally left blank

---

# Contents

---

1.1	General.....	1-5
1.2	System Unit Block Diagram.....	1-8
1.3	3.5-inch Floppy Disk Drive .....	1-10
1.4	3.5-inch Hard Disk Drive .....	1-11
1.5	Keyboard.....	1-12
1.6	Gas Plasma Display.....	1-13
1.7	Color Liquid Crystal Display .....	1-14
1.8	Power Supply Unit .....	1-15

## Tables

Table 1-1	T6400 models .....	1-5
Table 1-2	3.5-inch FDD specifications .....	1-10
Table 1-3	3.5-inch HDD specifications .....	1-11
Table 1-4	Gas plasma display specifications .....	1-13
Table 1-5	Color LCD specifications .....	1-14
Table 1-6	Power supply unit output ratings .....	1-15

## Figures

Figure 1-1	T6400 system unit.....	1-7
Figure 1-2	Block diagram.....	1-8
Figure 1-3	3.5-inch FDD .....	1-10
Figure 1-4	3.5-inch HDD .....	1-11
Figure 1-5	Keyboard.....	1-12
Figure 1-6	Gas plasma display .....	1-13
Figure 1-7	Color LCD .....	1-14
Figure 1-8	Power supply unit .....	1-15

This page intentionally left blank

# 1.1 General

The Toshiba T6400 is one of the lightest and most advanced portable computers available. Utilizing advanced technology and high speed components, the T6400 offers excellent display legibility and IBM PC/AT compatibility.

There are four models of the T6400 depending on the CPU, display type, and HDD capacity. Refer to Table 1-1 below.

*Table 1-1 T6400 models*

CPU	Display Type	HDD capacity (MB)
Intel 80486DX-33	PDP	200
	TFT	200
Intel 80486SX-25	PDP	120
	TFT	120

The T6400 system unit consists of the following features:

Microprocessor	The T6400 model uses an 80486SX-25 microprocessor that operates at 25 MHz. The T6400DX model uses an 80486DX-33 microprocessor that operates at 33 MHz.
Math co-processor	The T6400DX model has a Numeric Data Processor (NDP) inside the CPU. The T6400 comes with a built-in socket for an 80486DX-33 which incorporates a Numeric Data Processing Unit (NDP).
Cache memory	The T6400 has an 8 KB cache memory which is stored in the microprocessor.
Disk storage	The T6400 has an internal 120 or 200 Megabyte (MB) Hard Disk Drive (HDD) with an average access time of 19 milliseconds. A 3.5-inch Floppy Disk Drive (FDD) supports 2HD floppy disks (1.44 Mbytes) and 2DD floppy disks (720 Kbytes).

Memory	The T6400 comes standard with 4 MB of CMOS Random Access Memory (RAM). This includes 640 KB of conventional memory and 3456 KB of extended memory which can be utilized as expanded memory compatible with the Lotus/Intel/Microsoft Expanded Memory Specifications (LIM-EMS).
Display	The T6400 has two types of internal displays. They are an active matrix Thin Film Transistor (TFT) type color Liquid Crystal Display (LCD) 640x480 pixels, and a high resolution Plasma Display (PDP) 640x480 pixels with a 16-level gray scale.  The T6400 internal display controller supports Video Graphics Adapter (VGA) functions on the internal display devices.
Keyboard	The detachable easy-to-use 101/102-key keyboard with full size keys and standard spacing is compatible with IBM standard software.
Power supply	The universal auto-sensing power supply enables world-wide usage of the T6400 as long as a compatible AC plug is available.
Battery	The one Real Time Clock (RTC) battery keeps the date and time in addition to the system configuration parameters even if the system is powered off.
Expansion slot	The T6400 expansion slot is used to enhance the T6400 capabilities with various ISA adapter cards, which fit in one 8-bit or 16-bit full-size industry standard slot.
Parallel port	A Centronics-compatible parallel interface port serves two purposes. The port can be used to connect a Centronics-compatible printer or an external floppy disk drive.
RS-232-C port	The T6400 has one 9-pin serial interface port.
Keyboard port	The T6400 has an external PS/2 keyboard interface port on the right side.
Mouse port	The T6400 has one 6-pin mouse port on the back that can be used for connecting a PS/2 mouse.
RGB port	The T6400 has one 15-pin RGB port on the back that can be used for connecting an external video display.
Ext. 3.5" FDD port	The 26-pin FDD interface port allows you to connect the optional Toshiba external 3.5" FDD unit.
Built-in modem port	A Toshiba built-in modem can be installed inside the T6400.

Expansion port	The 150-pin expansion bus connector port allows you to connect unique optional Toshiba devices.
Memory slots	The T6400 has two expansion memory slots for installing the optional 2, 4, and/or 8 MByte memory cards.

The T6400 Personal Computer is shown in Figure 1-1.

*Figure 1-1 T6400 system unit*

---

## 1.2 System Unit Block Diagram

---

Figure 1-2 is a block diagram of the T6400 system unit.

*Figure 1-2 Block diagram*



The T6400 system board shown in Figure 1-2 is composed of the following major components:

- An 80486DX-33 or 80486SX-25 CPU
- Super Integration (SI) T9901 (208-pin), which stores the following components:
  - Two Direct Memory Access Controllers (DMACs): 82C37
  - Two Programmable Interrupt Controllers (PICs): 82C59
  - One Programmable Interval Timer (PIT): 82C54
  - One Floppy Disk Controller (FDC): TC8565
  - One Serial Input/Output controller (SIO): TC8570
  - One Variable Frequency Oscillator (VFO): TC8568
  - One I/O Controller
- A Real Time Clock (RTC): 146818AF
- A Keyboard Controller (KBC): 80C42
- Memory:
  - Standard RAM: 4 MB
  - Cache memory: 8 KB (inside CPU)
  - BIOS ROM: 1 MB  
This ROM contains the Initial Reliability Test (IRT), Basic Input/Output System (BIOS), and video BIOS.
  - Video RAM: 256 KB  
Optional memory cards expand memory to a maximum of 20 MB.
- System controller gate array: SYS CNT-GA (240-pin)
- VGA display controller: PVGA1F: WD90C23 (132-pin)
- Color gray scale controller gate array: CGSC-GA (60-pin)
- Digital analog converter: DAC (80-pin)
- The following Oscillators (OSC):
  - X1: 33.34 MHz or 25.0 MHz OSC is used for the CPU
  - X5: 14.31818 MHz OSC is used for the KBC
  - X6: 14.7456 MHz OSC is used for the SIO
  - X7: 24 MHz OSC is used for the FDC and VFO
  - X9: 44.9 MHz OSC is used for the display controller
  - X901: 28.322 MHz OSC is used for the display controller
  - X902: 25.175 MHz OSC is used for the display controller
  - X903: 32.768 KHz OSC is used for the RTC
  - X904: 36.0 MHz OSC is used for the display controller

---

## 1.3 3.5-inch Floppy Disk Drive

---

The T6400 3.5-inch Floppy Disk Drive (FDD) is a thin, high-performance, reliable drive that supports 720KB (formatted) 2DD and 1.44MB (formatted) 2HD 3.5-inch floppy disks.

The T6400 FDD is shown in Figure 1-3 and its specifications are described in Table 1-2.

*Figure 1-3 3.5-inch FDD*

<b>Item</b>	<b>2-Mbyte mode</b>	<b>1-Mbyte mode</b>
Storage capacity (Kbyte)		
Unformatted	2,000	1,000
Formatted	1,475	737
Number of heads	2	2
Number of cylinders	80	80
Access time (ms)		
Track to track	3	3
Average	94	94
Head settling time	15	15
Recording track density (tpi)	135	135
Data transfer rate (Kbps)	500	250
Rotation speed (rpm)	300	300
Recording method	Modified Frequency Modulation (MFM)	

---

*Table 1-2 3.5-inch FDD specifications*

## **1.4 3.5-inch Hard Disk Drive**

---

The T6400 120MB or 200MB (formatted) Hard Disk Drive (HDD) is a random access, non-volatile storage device. It has a non-removable 3.5-inch magnetic disk and mini-Winchester type magnetic heads.

The T6400 HDD is shown in Figure 1-4. Specifications for the HDD are described in Table 1-3.

*Figure 1-4 3.5-inch HDD*

<b>Item</b>	<b>200MB (CP-30204)</b>	<b>120MB (CP-30104)</b>
Storage capacity Formatted (MB)	212.6	121.5
Number of disks	2	2
Data heads	4	4
Data surfaces	4	4
Tracks per surface	2,119	1,522
Sectors per track	49	39 (+1)
Bytes per sector	512	512
Access time (ms)		
Track to track	3	8
Average	12	19
Maximum	30	40
Rotation speed (rpm)	4,498	3,400
Data transfer rate (MB/S)		
To/from media	2.5M	1.5M
Interleave	1:1	1:1
Recording method	2-7 RLL/ 1-7 RLL	2-7 RLL/ 1-7 RLL

## **1.5 Keyboard**

---

The 101-key (USA) or 102-key (European) keyboard is mounted on the T6400's system unit. The keyboard is connected to the keyboard controller in the keyboard unit. The keyboard is shown in Figure 1-5.

See Appendix E for optional keyboard configurations.

*Figure 1-5 Keyboard*

---

## 1.6 Gas Plasma Display

---

The gas plasma display is composed of a display panel and driver circuits. It receives vertical and horizontal synchronizing signals, four-bit data signals, and shift clock for data transmission. All signals are TTL-level compatible. The display has 16 levels of gray scale and the display quality can be adjusted with the contrast control.

The gas plasma display is shown in Figure 1-6 and its specifications are described in Table 1-4.

*Figure 1-6 Gas plasma display*

<b>Item</b>		<b>Specifications</b>
Number of dots	(dots)	640 x 480
Dot pitch	(mm)	0.33 (W) x 0.33 (H)
Display area	(mm)	158.4 (W) x 211.2 (H)
Color		Neon-Orange
Contrast ratio		100:1
Gray scale		16 levels
Power (maximum)		20 watts
Mean time between failure (MTBF)	(hours)	20,000

## 1.7 Color Liquid Crystal Display

---

The color liquid crystal display (LCD) is composed of an LCD module, fluorescent lamps (FLs), and an FL inverter board. The thin film transistor (TFT) LCD is illuminated from the back. Thus, you can read its display clearly even in poorly lit conditions. It receives vertical and horizontal synchronizing signals, 9-bit data signals, and shift clock signals for data transmission. All signals are TTL-level compatible. The LCD specifications are described in Table 1-5.

The LCD has 512-color capability. The high frequency current is supplied by the FL inverter board to illuminate the FLs. The color LCD is shown in Figure 1-7.

Figure 1-7 Color LCD

Item		Specifications
Number of dots	(dots)	640 x 480
Dot pitch	(mm)	0.33 (W) x 0.33 (H)
Display area	(mm)	211.2 (W) x 158.4 (H)
Color		512 colors
Contrast ratio		60:1
Gray scale		8 levels for each gun (RGB)
Power (maximum)		19 watts

## 1.8 Power Supply Unit

---

The universal auto-sensing power supply can be used world-wide and supplies +5, -5, +12, and -12 VDC to the system.

The power supply unit is housed in the system unit and it supplies regulated power to the:

- System board
- Memory board
- 3.5-inch floppy disk drive (FDD)
- 3.5-inch hard disk drive (HDD)
- External keyboard
- Liquid crystal display (LCD) or plasma display (PDP)
- Option boards
- Cooling fans

The power supply unit includes an input line filter, line fuse, cooling fans, power conversion circuitry, and connectors.

Input ratings are: 115 VAC, 1.5 A or 230 VAC, 1.0 A

The power supply unit is shown in Figure 1-8 and the output ratings are specified in Table 1-6.

Figure 1-8 Power supply unit

	DC voltage (V)	Maximum current (A)
For system	+5	6.09
	+12	0.9 (1.32)
	-5	0.15
	-12	0.25
	+24	20 (17)

Table 1-6 Power supply unit output ratings

---

This page intentionally left blank



---

# **Chapter 2**

## **Troubleshooting Procedures**

---

This page intentionally left blank

---

# Contents

---

2.1	T6400 Troubleshooting .....	2-5
2.2	Troubleshooting Flowchart .....	2-6
2.3	Power Supply Unit Troubleshooting Procedures .....	2-8
	Procedure 1 AC Cord Check .....	2-9
	Procedure 2 Connector Check .....	2-10
	Procedure 3 Output Voltage Check .....	2-11
2.4	System Board Troubleshooting Procedures .....	2-12
	Procedure 1 Message Check .....	2-13
	Procedure 2 Printer Port LED Check .....	2-15
	Procedure 3 Diagnostic Test Program Execution Check .....	2-19
2.5	Floppy Disk Drive Troubleshooting Procedures .....	2-20
	Procedure 1 FDD Head Cleaning Check .....	2-21
	Procedure 2 External 5-1/4" FDD Check .....	2-22
	Procedure 3 Diagnostic Test Program Execution Check .....	2-23
	Procedure 4 Connector and Replacement Check .....	2-24
2.6	Hard Disk Drive Troubleshooting Procedures .....	2-25
	Procedure 1 Message Check .....	2-26
	Procedure 2 Partition Check .....	2-27
	Procedure 3 Format Check .....	2-28
	Procedure 4 Diagnostic Test Program Execution and Replacement Check .....	2-29
2.7	Keyboard Troubleshooting Procedures .....	2-30
	Procedure 1 Diagnostic Test Program Execution Check .....	2-31
	Procedure 2 Connector and Replacement Check .....	2-32
2.8	Display Troubleshooting Procedures .....	2-33
	Procedure 1 Brightness Volume Check (for Plasma Type) .....	2-34
	Procedure 2 External CRT Check .....	2-35
	Procedure 3 Diagnostic Test Program Execution Check .....	2-36
	Procedure 4 Connector Check .....	2-37
	Procedure 5 Replacement Check .....	2-38

## Tables

Table 2-1	Output voltages .....	2-11
Table 2-2	Printer port LED test status .....	2-16
Table 2-3	Floppy disk drive error codes and status .....	2-23
Table 2-4	Hard disk drive error codes and statuses .....	2-28

## Figures

Figure 2-1	Troubleshooting flowchart .....	2-6
Figure 2-2	Printer port LED .....	2-15

This page intentionally left blank

---

## 2.1 T6400 Troubleshooting

---

Chapter 2 describes how to determine if a Field Replaceable Unit (FRU) in the T6400 is causing the computer to malfunction. The FRUs covered are:

1. Power supply unit
2. System board
3. Floppy Disk Drive
3. Hard Disk Drive
4. Keyboard
5. Display

The following tools will assist you in performing the T6400 troubleshooting procedures.

1. T6400 Diagnostic Disk
2. Phillips head screwdriver (2 mm)
3. Toshiba MS-DOS system disk
4. 2DD or 2HD formatted work disk for the floppy disk drive troubleshooting
5. Cleaning disk kit for the floppy disk drive troubleshooting
6. Printer port LED
7. RS-232-C wraparound connector
8. Printer wraparound connector
9. Expansion slot wraparound board (F32BUS)
10. Multimeter
11. External 5.25" and 3.5" floppy disk drives
12. External CRT
13. External keyboard
14. PS/2 mouse and driver software

## 2.2 Troubleshooting Flowchart

Use the flowchart in Figure 2-1 as a guide to determine which FRU troubleshooting procedures to execute. Before performing the flowchart procedures, perform the following:

- Disconnect all optional equipment from the T6400.
- Remove any diskette in the FDD.

**NOTE:** If you forget the password and cannot start up the computer, connect the printer port wraparound board (F31PRT), then turn the POWER switch on. The computer will skip the password function.

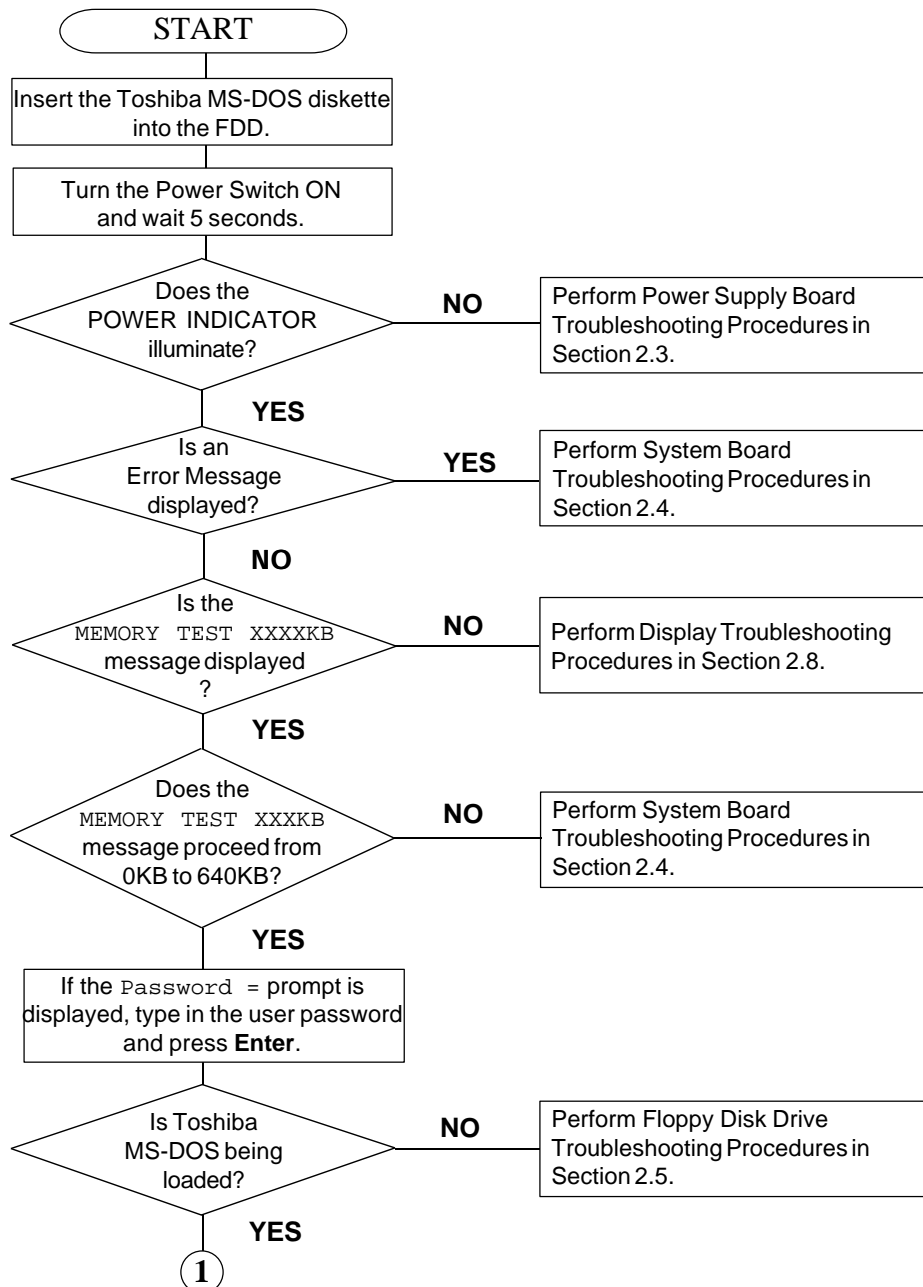

Figure 2-1 Troubleshooting flowchart

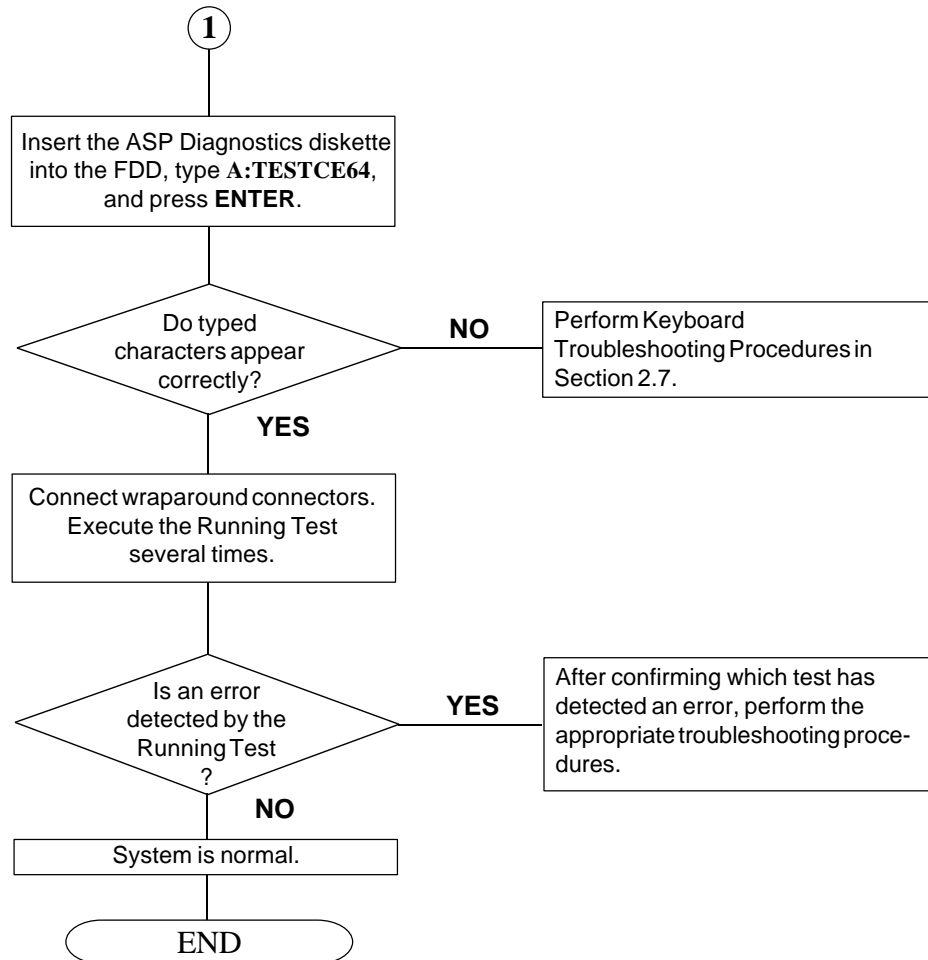

Figure 2-1 Troubleshooting flowchart (continued)

If the Diagnostic Program does not detect any errors, the problem may be an intermittent one. Execute the running test program several times to isolate the problem.

After confirming which diagnostic test detected an error by checking the Log Utilities function, perform the appropriate troubleshooting procedures as follows.

1. If an error is detected on the system test, memory test, display test, ASYNC test, printer test, real timer test, or expansion test, perform the system board troubleshooting procedures in Section 2.4.
2. If an error is detected on the keyboard test, perform the keyboard troubleshooting procedures in Section 2.7.
3. If an error is detected on the floppy disk test, perform the floppy disk drive troubleshooting procedures in Section 2.5.
4. If an error is detected on the hard disk test, perform the hard disk drive troubleshooting procedures in Section 2.6.

---

## 2.3 Power Supply Unit Troubleshooting Procedures

---

**WARNING:** *Dangerously high voltage is supplied to the power supply unit. Be extremely cautious when handling this unit. Wait a few minutes after turning the power off to allow the electricity to discharge.*

The T6400's power supply unit generates a variety of voltages for each component. To determine if the power supply unit is functioning properly, perform the following checks as required. Start with Procedure 1 and continue with the other procedures as instructed.

Procedure 1: AC Cord Check

Procedure 2: Connector Check

Procedure 3: Output Voltage Check



## **Procedure 1 AC Cord Check**

The T6400's AC cord carries AC voltage to the T6400's power supply unit from a wall outlet.

Check 1      Turn off the power, then disconnect the AC cord from the T6400. Use a multimeter to check the output voltage from the wall outlet and on the AC cord.

If the output voltages are different, replace the AC cord. If the output voltages are the same, perform Procedure 2.

## Procedure 2 Connector Check

The T6400's power supply cables are connected on the system board. These cables may be disconnected from the system board or damaged. Disassemble the T6400 following the steps described in Chapter 4 to check the power supply cables and their connections to the system board.

- Check 1 Remove the system board cover. Make sure the power supply cables are connected to the system board.

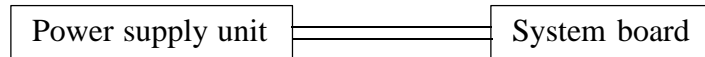

If these cables are disconnected, connect them to the system board. If these cables are damaged, replace the power supply unit.

If these cables are OK, perform Procedure 3.

### Procedure 3 Output Voltage Check

The T6400's power supply supplies five voltages to the system board. Check the output voltages of the power supply unit.

Check 1 Remove the system board cover, connect the power supply cables to the system unit, connect the AC Cord, and turn on the power.

Use a multimeter to check the following voltages.

*Table 2-1 Output voltages*

Connector	Pin number		Voltage (V)
	+	-	
PJ1	1	3 or 4	+5 (±5%)
	2	3 or 4	+5 (±5%)
PJ2	1	GND	-5 (±5%)
	2	GND	+12 (±5%)
	3	GND	-12 (±5%)
	4	GND	+24 (±10%)
	5	GND	+12 (±10%)
	6	GND	+12 (±8/-4)

If the output voltages are not correct, replace the power supply unit.

---

## 2.4 System Board Troubleshooting Procedures

---

To determine if the system board is defective or not functioning properly perform the following procedures beginning with Procedure 1 and continue with the other Procedures as required.

Procedure 1: Message Check

Procedure 2: Printer Port LED Check

Procedure 3: Diagnostic Test Program Execution Check

## Procedure 1 Message Check

When the power is turned on, the system performs the Initial Reliability Test (IRT) installed in the BIOS ROM. The IRT tests each IC on the system board and initializes it.

If an error message is displayed, perform Check 1. If not, go to Procedure 2. If Toshiba MS-DOS is properly loaded, go to Procedure 3.

**Check 1** If the following error message is displayed on the screen for one second, the external FDD is not connected, even though the external FDD/PRT option in the SETUP program is set to FDD A.

Set the external FDD/PRT option to FDD B or PRT, or connect the external FDD and restart the system. If any other error message appears, execute Check 2.

**\*\*\* FDD A is not installed \*\*\***

**Check 2** If one of the following error messages is displayed on the screen, press any key as the message instructs.

These errors occur when the system configuration stored in the RTC memory (CMOS type memory) is not the same as the actual one or the data is lost.

If you press any key as the message instructs, the system configuration in the RTC memory configuration is set to the default setting. If error message (b) appears often when the power is turned on, replace the RTC battery. If any other error message is displayed, perform Check 3.

- (a) **\*\*\* Error in CMOS. Bad HDD type \*\*\***  
Check system. Then press any key .....
- (b) **\*\*\* Error in CMOS. Bad battery \*\*\***  
Check system. Then press any key .....
- (c) **\*\*\* Error in CMOS. Bad check sum \*\*\***  
Check system. Then press any key .....
- (d) **\*\*\* Error in CMOS. Bad memory configuration \*\*\***  
Check system. Then press any key .....
- (e) **\*\*\* Error in CMOS. Bad time function \*\*\***  
Check system. Then press any key .....

Check 3 The IRT tests the system board. When the IRT detects an error, the system stops or an error message appears. Refer to the messages in Table 2-2 to determine which test item failed.

If one of the following (a) through (r) error messages is displayed, replace the system board.

If error message (s) is displayed, go to the Keyboard Troubleshooting Procedures in Section 2.7.

If error message (t) or (u) is displayed, go to the HDD Troubleshooting Procedures in Section 2.6.

If error message (v) is displayed, go to the FDD Troubleshooting Procedures in Section 2.5.

If none of these error messages appears, go to Procedure 2.

- (a) **TIMER CH.2 OUT ERROR**
- (b) **PIT ERROR**
- (c) **MEMORY REFRESH ERROR**
- (d) **TIMER CH.2 OUT ERROR**
- (e) **FIRST 64KB MEMORY ERROR**
- (f) **CRTC ERROR**
- (g) **VRAM ERROR**
- (h) **KBC ERROR**
- (i) **SYSTEM MEMORY ERROR**
- (j) **SYSTEM MEMORY PARITY ERROR**
- (k) **EXTENDED MEMORY ERROR**
- (l) **EXTENDED MEMORY PARITY ERROR**
- (m) **DMA PAGE REGISTER ERROR**
- (n) **DMAC #x ERROR**
- (o) **PIC #x ERROR**
- (p) **FDC ERROR**
- (q) **RTC UPDATE ERROR**
- (r) **TIMER INTERRUPT ERROR**
- (s) **KEYBOARD ERROR**
- (t) **HDC ERROR**
- (u) **HDD #x ERROR**
- (v) **NO FDD ERROR**

## Procedure 2 Printer Port LED Check

The printer port LED displays the IRT status and test status by turning lights on and off as an eight-digit binary value. Figure 2-2 shows the printer port LED.

**NOTE:** When you perform this check, the external FDD/PRT option in the SETUP program must be set to PRT.

*Figure 2-2 Printer port LED*

To use the printer port LED, follow these steps:

1. Turn off the T6400's power.
2. Plug the printer port LED into the T6400's PRT/FDD connector.
3. Turn on the T6400's power.
4. Read the final LED status from left to right as you are facing the back of the computer. Convert the status from binary to hexadecimal notation.

**NOTE:** The final status on the LED indicates the last test successfully completed before an error was detected. The error message displayed on the screen will be for the test status in Table 2-2 following the test status given on the printer port LED.

5. If the final LED status is FFh (normal status), go to Procedure 3.
6. If the final LED status matches any of the test status values in Table 2-2, perform Check 1.

Table 2-2 Printer port LED test status

Printer Port LED Indication		Test Status	Test Item	Message
A	B			
○○○○○	○○○○●	01H	Pre-init for warm start test	-
○○○○○	○●○○●	05H	PIT test	TIMER CH. 2 OUT ERROR PIT ERROR READ DATA = XXH WRITE DATA = XXH
○○○○○	○●●○○	06H	PIT initialization	-
○○○○○	○●●●●	07H	PIT function test	MEMORY REFRESH ERROR
○○○○○	●○○●○	0AH	First 64KB memory test	FIRST 64KB MEMORY ERROR
○○○○○	●○○●●	0BH	System memory initialization	-
○○○○○	●●○○●	0DH	Interrupt vector initialization	-
○○○○●	○●○○●	15H	RTC test	RTC ERROR READ DATA = XXH WRITE DATA = XXH
○○○○●	○●○○●	15H	CMOS RAM test	****Error in CMOS. Bad battery**** ****Error in CMOS. Bad check sum**** ****Error in CMOS. Bad configuration**** ****Error in CMOS. Bad memory size**** ****Error in CMOS. Bad HDD type**** ****Error in CMOS. Bad time function**** Check system. Then press [F1] key..
○○○○●	○●●○○	16H	RTC initialization	-
○○○○●	●○○○○	18H	PIC initialization	-
○○○○●	●●●●●	1FH	Display initialization	CRTC ERROR VRAM ERROR READ DATA = XXXXXXXXH WRITE DATA = XXXXXXXXH
○○●○○	○○●○○	22H	KBC test	KBC ERROR
○○●○○	○●○○●	25H	System memory test	SYSTEM MEMORY ERROR ADDRESS = XXXXXXXXH READ DATA = XXXXXXXXH WRITE DATA = XXXXXXXXH SYSTEM MEMORY PARITY ERROR ADDRESS = XXXX0000H - XXXXFFFFH
○○●●○	○○○○○	30H	Extended memory test	EXTENDED MEMORY ERROR ADDRESS = XXXXXXXXH READ DATA = XXXXXXXXH WRITE DATA = XXXXXXXXH EXTENDED MEMORY PARITY ERROR ADDRESS = XXXX0000H - XXXXFFFFH

● = On  
○ = Off



Table 2-2 Printer port LED test status (continued)

Printer Port LED Indication		Test Status	Test Item	Message
A	B			
○●○○○	○○○○○	40H	DMA page register test	DMA PAGE REGISTER ERROR READ DATA = XXH WRITE DATA = XXH
○●○○○	○○○○●	41H	DMAC test	DMAC #1 ERROR READ DATA = XXXXH WRITE DATA = XXXXH
				DMAC #2 ERROR READ DATA = XXXXH WRITE DATA = XXXXH
○●○○○	○○●○○	42H	DMAC initialization	-
○●○○○	●○○●○	4AH	PIC test	PIC #1 ERROR READ DATA = XXH WRITE DATA = XXH
				PIC #2 ERROR READ DATA = XXH WRITE DATA = XXH
○●○○●	○●○○○	54H	Keyboard test	KEYBOARD ERROR
○●○○●	○●○○●	55H	KBC initialization	KBC ERROR
○●○○●	●○○●○	5AH	Mouse initialization	-
○●●○○	○○○○○	60H	HDD initialization	HDC ERROR
				HDD #0 ERROR
				HDD #1 ERROR
○●●○○	○●○○●	65H	FDD initialization	NO FDD ERROR
				FDD ERROR
○●●●○	○○○○○	70H	Printer test	-
●○○○○	○○○○○	80H	RS-232-C	-
●○○○●	○○○○○	90H	Timer initialization	TIMER INTERRUPT ERROR
				RTC UPDATE ERROR
●○○●○	○○○○○	A0H	NDP initialization	-
●○○●○	○●●○○	A6H	Expansion I/O ROM	-
●●●●○	●●●●○	FFH	Expansion system ROM	-

● = On  
○ = Off

- Check 1 If the following test codes are displayed, replace the system board with a new one.
- 01h, 05h, 06h, 07h, 0Ah, 0Dh, 15h, 16h, 18h, 1Fh, 22h,  
25h, 30h, 40h, 41h, 42h, 54h, 65h, 70h, 80h, 90h, A0h,  
A6h
- Check 2 If test code 4A is displayed, go to the Keyboard Troubleshooting Procedures in Section 2.7.
- Check 3 If test code 55 is displayed, make sure the mouse cable is firmly connected to the system board. If it is, replace the system board with a new one.
- Check 4 If test code 5A is displayed, go to the HDD Troubleshooting Procedures in Section 2.6.

Check 5     If test code 60 is displayed, go to the FDD Troubleshooting Procedures in Section 2.5.  
**Procedure 3 Diagnostic Test Program Execution Check**

Execute the following tests from the Diagnostic Test Menu. Refer to Chapter 3, “*Tests and Diagnostics*” for detailed instructions on how to perform these tests.

1.     System test
2.     Memory test
3.     Printer test
4.     ASYNC test
5.     Real timer test
6.     NDP test (if the NDP is installed.)

If an error is detected during these tests, replace the system board with a new one.

---

## 2.5 Floppy Disk Drive Troubleshooting Procedures

---

This section describes how to determine if the T6400's internal 3.5" floppy disk drive is functioning properly. Perform the procedures below starting with Procedure 1 and continuing with the other procedures as instructed.

Procedure 1: FDD Head Cleaning Check

Procedure 2: External 5-1/4" FDD Check

Procedure 3: Diagnostic Test Program Execution Check

Procedure 4: Connector and Replacement Check

**Procedure 1 FDD Head Cleaning Check**

FDD head cleaning is one of the options available in the Diagnostic Program. Detailed operation is described in Chapter 3, "*Tests and Diagnostics.*"

After loading Toshiba MS-DOS, run the Diagnostic Program and then clean the FDD heads using the cleaning kit. If the FDD still does not function properly after cleaning, go to Procedure 3.

If the test program cannot be executed, go to Procedure 2.

## Procedure 2 External 5-1/4" FDD Check

The floppy disk controller on the computer's system board controls the internal and external FDD. To determine if either the system board or the internal FDD is defective, check the following items:

Check 1     Connect the external 5-1/4" FDD to the PRT/FDD port and make sure it functions properly. If it does, perform Check 2. If it doesn't, perform Check 4.

*NOTE:* To use the external 5-1/4" FDD, set the external FDD/PRT option in the SETUP program to FDD A or FDD B.

Check 2     Disassemble the system unit and make sure the internal FDD cable is properly connected to PJ4 on the system board. If it is, perform Check 3.

Check 3     Replace the internal 3.5" FDD with a new one. If the problem still exists, perform Check 4.

Check 4     Replace the system board with a new one.

### Procedure 3 Diagnostic Test Program Execution Check

The Floppy Disk Drive Diagnostic Test program is stored on the T6400 Diagnostic Disk. After loading Toshiba MS-DOS, run the Diagnostic Program (TESTCE64). Refer to Chapter 3, *Tests and Diagnostics*, for more information about the diagnostic test procedures.

Floppy disk drive test error codes and their status names are described in Table 2-3. Make sure the floppy disk in the FDD is formatted correctly and that the write protect tab is disabled. If any other errors occur while executing the FDD diagnostic test, go to Check 1.

Code	Status
01h	Bad command
02h	Address mark no found
03h	Write protected
04h	Record not found
06h	Media removed on dual attach card
08h	DMA overrun error
09h	DMA boundary error
10h	CRC error
20h	FDC error
40h	Seek error
60h	FDD not drive
80h	Time out error (Not ready)
EEh	Write buffer error

*Table 2-3 Floppy disk drive error codes and status*

- Check 1     If the following message is displayed, disable the write protect tab on the floppy disk. If any other message appears, go to Procedure 4.

## Write protected

### Procedure 4 Connector and Replacement Check

The 3.5" Floppy Disk Drive is connected to the system unit by the FDD cable. This cable may be disconnected from the system unit or damaged. Disassemble the T6400 following the Procedures described in Chapter 4, *Replacement Procedures*, and perform the following checks.

Check 1 Make sure the FDD cable is firmly connected to the system board.

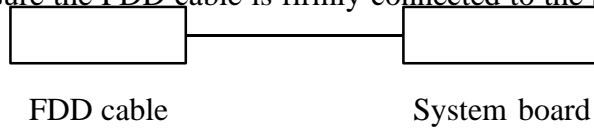

If this cable is disconnected, connect it to the system unit and repeat Procedure 3. If the FDD is still not functioning properly, perform Check 2.

Check 2 The FDD or its cable may be defective or damaged. Replace the FDD with a new one. If the FDD is still not functioning properly, perform Check 3.



---

Check 3     Replace the system board with a new one following the steps in Chapter 4, *Replacement Procedures*.

## 2.6     **Hard Disk Drive Troubleshooting**

---

### **Procedures**

To determine if the hard disk drive is functioning properly, follow the procedures below starting with Procedure 1. Continue with the other procedures as instructed.

Procedure 1: Message Check

Procedure 2: Partition Check

Procedure 3: Format Check

Procedure 4: Diagnostic Test Program Execution and Replacement Check

**CAUTION:** *The contents of the hard disk will be erased when the HDD Troubleshooting Procedures are executed. Transfer the contents of the hard disk to floppy disks using the*

*Toshiba MS-DOS BACKUP command. Refer to the Toshiba MS-DOS manual for more information about how to perform the BACKUP command.*

### **Procedure 1 Message Check**

When the T6400's HDD is not functioning properly, some of the following error messages may appear on the display. Start with Check 1 below and perform the other checks as required.

Check 1 If any of the following messages appear, perform Check 2. If the following messages do not appear, perform Check 4.

**HDC ERROR**  
(After 5 seconds this message will disappear.)

or

**HDD #0 ERROR**  
(After 5 seconds this message will disappear.)

or

**HDD #1 ERROR**  
(After 5 seconds this message will disappear.)

Check 2 If either of the following messages appear, perform Procedure 2. If the following messages do not appear, perform Check 3.

**Insert system disk in drive**  
**Press any key when ready .....**

or

**Non-System disk or disk error**  
**Replace and press any key when ready.**

Check 3 Using the Toshiba MS-DOS system disk, install a system program on the hard disk using the SYS command.

If the following message appears on the display, the system program has been transferred to the HDD. Restart the T6400. If the error message still appears, perform Check 4.

**System transferred**

If an error message appears on the display, refer to the *Toshiba MS-DOS Manual* for more information about the error message and perform Check 4.

Check 4 The HDD is connected to the system board through an HDD interface cable and power cable. These cables can become disconnected or damaged. Disassemble the T6400 as described in Chapter 4, *Replacement Procedures*. If the HDD is not connected, con-

## Procedure 2 Partition Check

Insert the Toshiba MS-DOS system disk and turn on the computer. Then perform the following checks.

- Check 1     Type **C:** and press **Enter**. If you cannot change to drive C, go to Check 2. If you can change to drive C, go to Procedure 3.
  
- Check 2     Type **FDISK** and press **Enter**. Choose Display Partition Information from the FDISK menu. If drive C is listed, go to Check 3. If drive C is not listed, return to the FDISK menu and choose to create a DOS partition on drive C. Then recheck the system. If the problem still exists, go to Procedure 3.
  
- Check 3     If drive C is listed as active in the FDISK menu, go to Check 4. If drive C is not listed as active, return to the FDISK menu and choose to set the active partition for drive C. Then recheck the system. If the problem still exists, go to Procedure 3.
  
- Check 4     Remove the system disk from the FDD and cold boot the computer. If the problem still exists, go to Procedure 3. Otherwise, the HDD is operating normally.

nect it to the system board. If the HDD is firmly connected to the system board, perform Procedure 2.

### **Procedure 3 Format Check**

The T6400's HDD is formatted using the low level (physical) format program and the Toshiba MS-DOS FORMAT program. To format the HDD, start with Check 1 below and proceed as instructed.

Check 1 Using the Toshiba MS-DOS system disk, partition the hard disk using the FDISK command. Format the hard disk using the FORMAT C:/S to transfer the system program to the HDD. If the following message appears on the display, the HDD is formatted.

**Format complete**

If any other error messages appear on the display, refer to the *Toshiba MS-DOS Manual* for more information about the error message and perform Check 2.

Check 2 Using the T6400 Diagnostic Disk, format the HDD with the low level format option. Refer to Chapter 3, *Tests and Diagnostics* for more information about the Diagnostic Program.

If the following message appears on the display, the HDD low level format is complete. Partition and format the HDD using the Toshiba MS-DOS FORMAT command.

**Format complete**

If you cannot format the HDD, go to Procedure 4.

#### Procedure 4 Diagnostic Test Program Execution and Replacement Check

The HDD test program is stored in the T6400 Diagnostic Disk. Perform all of the HDD subtests in the Hard Disk Drive Test. Refer to Chapter 3, *Tests and Diagnostics* for more information about the HDD test program.

If an error is detected during the HDD test, an error code and status will be displayed; perform Check 1. The error code and status are described in Table 2-4. If an error code is not generated, the HDD is operating properly.

Code	Status
01h	Bad command
02h	Bad address mark
04h	Record not found
05h	HDC not reset
07h	Drive not initialize
09h	DMA boundary error
0Ah	Bad sector error
0Bh	Bad track error
10h	ECC error
11h	ECC recover enable
20h	HDC error
40h	Seek error
80h	Time out error
AAh	Drive not ready
BBh	Undefined
CCh	Write fault
E0h	Status error
F0h	Not sense error (HW. code = FF)

Table 2-4 Hard disk drive error codes and statuses

- Check 1     Replace the HDD unit with a new one following the instructions in Chapter 4, *Replacement Procedures*. If the HDD is still not functioning properly, perform Check 2.
- Check 2     Replace the system board with a new one following the instructions in Chapter 4,

## **2.7 Keyboard Troubleshooting Procedures**

---

To determine if the T6400's keyboard is functioning properly, perform the following procedures. Start with Procedure 1 and continue with the other procedures as instructed.

Procedure 1: Diagnostic Test Program Execution Check

Procedure 2: Connector and Replacement Check  
**Procedure 1 Diagnostic Test Program Execution Check**

Execute the keyboard test in the Diagnostic Test program. Refer to Chapter 3, *Tests and Diagnostics* for more information on how to perform the test program.

If an error occurs, go to Procedure 2. If an error does not occur, the keyboard is functioning properly.

### Procedure 2 Connector and Replacement Check

The T6400 detectable keyboard unit is controlled by a keyboard interface controller (KBIC) and keyboard scan controller (KBSC). The KBIC is mounted on the system board and controls the external PS/2 keyboard port and PS/2 mouse port.

These components and the keyboard are connected by two cables. These cables can become disconnected or damaged. Disassemble the T6400 as described in Chapter 4 and follow the checks below.

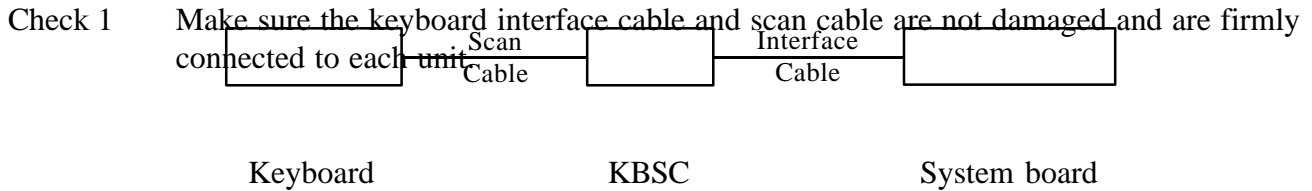

If these cables are damaged, replace them with new ones, or connect them if they are disconnected. If these cables are connected correctly, perform Check 2.

Check 2    The keyboard scan controller board may be damaged. Replace it with a new one. If the error still occurs, perform Check 3.

Check 3    The keyboard may be damaged. Replace it with a new one. If the error still occurs,



---

perform Check 4.

---

Check 4 The system board may be damaged. Replace it with a new one.

## **2.8 Display Troubleshooting Procedures**

This section describes how to determine if the T6400's display is not functioning properly. Start with Procedure 1 and continue with the other procedures as instructed. The procedures described in this section are:

Procedure 1: Brightness Volume Check (for Plasma Type)

Procedure 2: External CRT Check

Procedure 3: Diagnostic Test Program Execution Check

Procedure 4: Connector Check

Procedure 5: Replacement Check

**Procedure 1 Brightness Volume Check (for Plasma Type)**

This check is for plasma displays. If your T6400 has a color LCD display, go to Procedure 2.

The brightness dial is on the right side of the display unit. Use this dial to adjust the display screen.

If the brightness does not change when you adjust it, go to Procedure 2.

**Procedure 2 External CRT Check**

Connect the external CRT to the T6400's RGB port, then cold boot the computer. The computer automatically detects the external CRT.

If the external the CRT works correctly, the internal color LCD or plasma display may be damaged.

Go to Procedure 4.

If the external CRT has the same problem, the display controller may be damaged. Go to Procedure 3.

### **Procedure 3 Diagnostic Test Program Execution Check**

The display test program is stored on the T6400 Diagnostic Diskette. This program checks the display controller on the system board. After loading Toshiba MS-DOS, run the Diagnostic Program (TESTCE64). Refer to Chapter 3, *Tests and Diagnostics*, for detailed instructions about the

display test.

If an error is detected, go to Procedure 4. If an error is not detected, the display is functioning properly.

#### Procedure 4 Connector Check

##### Color LCD

The display unit has an LCD module and FL inverter board. The Sharp color LCD also includes a DC-DC converter board. The LCD module and FL inverter board are connected by four cables. The LCD module and system board are connected by two signal cables. Any of these cables may be disconnected.

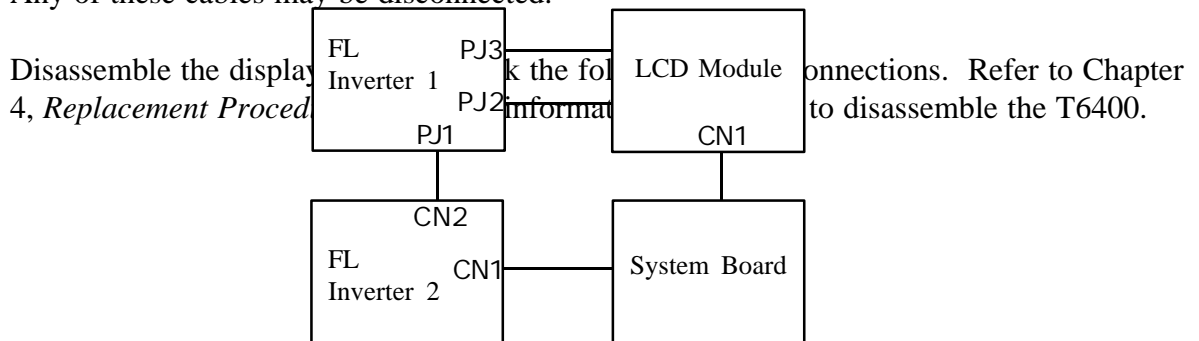

If any of the cables are not connected, firmly reconnect them and perform Procedures 1 and 2 again. If the problem still exists, go to Procedure 5.

##### Plasma Display

The plasma display is connected to the system board through three display cables. Any of these cables may be disconnected.

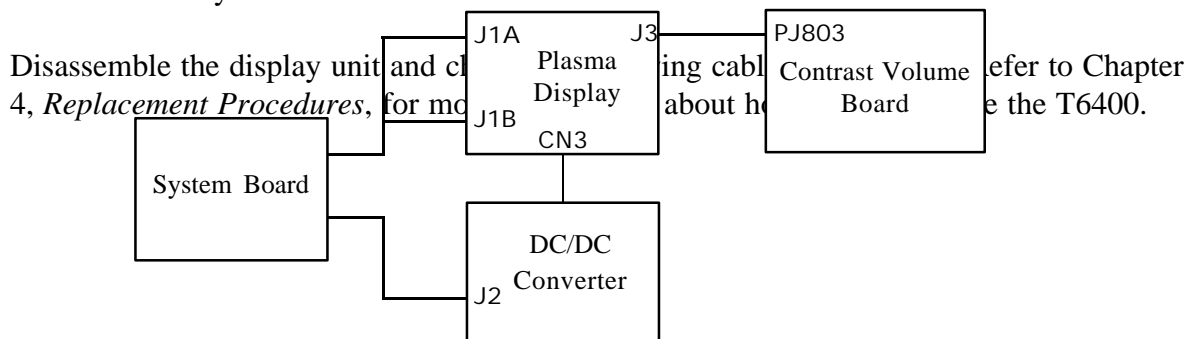

If any of the cables are not connected, firmly reconnect them and perform Procedures 1 and 2 again. If the problem still exists, go to Procedure 5.

### **Procedure 5 Replacement Check**

#### *Color LCD*

The FL inverter board, LCD module, and system board are connected to the display circuits. Any of these units may be damaged. Refer to Chapter 4, *Replacement Procedures*, for instructions on how to disassemble the system unit and then perform the following checks.

- Check 1 Replace the FL inverter board with a new one and test the display again. If the problem still exists, perform Check 2.
- Check 2 Replace the LCD module with a new one and test the display again. If the problem still exists, perform Check 3.
- Check 3 Replace the display cable with a new one and test the display again. If the problem still exists, perform Check 4.
- Check 4 The system board may be damaged. Replace the system board with a new one and test the display again.

#### *Plasma Display*

Refer to Chapter 4, *Replacement Procedures*, for instructions on how to disassemble the system unit and then perform the following checks.

- Check 1 Replace the plasma display unit with a new one and test the display again. If the problem still exists, perform Check 2.
- Check 2 Replace the display cable with a new one and test the display again. If the problem still exists, perform Check 3.
- Check 3 The system board may be damaged. Replace the system board with a new one and test the display again.

---

# **Chapter 3**

## **Tests and Diagnostics**

---

This page intentionally left blank



---

# Contents

---

3.1	Diagnostic Program .....	3-5
3.2	Executing the T6400 Diagnostic Program .....	3-7
3.3	Subtest Names .....	3-10
3.4	System Test .....	3-12
3.5	Memory Test.....	3-13
3.6	Keyboard Test.....	3-15
3.7	Display Test.....	3-17
3.8	Floppy Disk Test.....	3-22
3.9	Printer Test .....	3-24
3.10	ASYNC Test .....	3-26
3.11	Hard Disk Test .....	3-28
3.12	Real Timer Test .....	3-31
3.13	Numeric Data Processor Test .....	3-32
3.14	Expansion Unit Test .....	3-33
3.15	Error Code and Error Status Names .....	3-35
3.16	Hard Disk Test Detail Status .....	3-37
3.17	Hard Disk Format .....	3-39
	3.17.1 Function Description .....	3-39
	3.17.2 Operations .....	3-40
3.18	Head Cleaning.....	3-43
	3.18.1 Function Description .....	3-43
	3.18.2 Operations .....	3-43
3.19	Seek to Landing Zone (HDD).....	3-44
	3.19.1 Function Description .....	3-44
	3.19.2 Operations .....	3-44
3.20	Log Utilities.....	3-45
	3.20.1 Function Description .....	3-45
	3.20.2 Operations .....	3-45
3.21	Running Test.....	3-47
	3.21.1 Function Description .....	3-47
	3.21.2 Operations .....	3-47
3.22	Floppy Disk Drive Utilities.....	3-48
	3.22.1 Function Description .....	3-48
	3.22.2 Operations .....	3-48
3.23	System Configuration .....	3-52
	3.23.1 Function Description .....	3-52
	3.23.2 Operations .....	3-52
3.24	SETUP .....	3-53
	3.24.1 Function Description .....	3-53
	3.24.2 Accessing the SETUP .....	3-54
	3.24.3 Changing SETUP Values .....	3-55
	3.24.4 SETUP Option Descriptions .....	3-56

## Tables

Table 3-1	Subtest names.....	3-10
Table 3-2	T6400 hardware bit status .....	3-12
Table 3-3	Error codes and error status names .....	3-35
Table 3-4	HDC status register contents .....	3-37
Table 3-5	HDC Error register contents .....	3-38
Table 3-6	Hard disk formatting sequence .....	3-39

---

## 3.1 Diagnostic Program

---

This chapter explains how to use the T6400's Diagnostic Program (TESTCE64) to test the functions of all the T6400's hardware modules. The Diagnostic Program is located on the T6400 Diagnostic Diskette. The Diagnostic Programs consists of 20 programs that are divided into the Service Program Module (DIAGNOSTICS MENU) and the Test Program Module (DIAGNOSTIC TESTMENU).

The Service Program Module consists of the following nine functions:

1. DIAGNOSTIC TEST
2. HARD DISK FORMAT
3. SEEK TO LANDING ZONE (HDD)
4. HEAD CLEANING
5. LOG UTILITIES
6. RUNNING TEST
7. FDD UTILITIES
8. SYSTEM CONFIGURATION
9. SETUP

The Test Program Module contains the following 11 functional tests. These are all located within the Diagnostic Test function of the Service Program Module.

1. SYSTEM TEST
2. MEMORY TEST
3. KEYBOARD TEST
4. DISPLAY TEST
5. FLOPPY DISK TEST
6. PRINTER TEST
7. ASYNC TEST
8. HARD DISK TEST
9. REAL TIMER TEST
10. NDP TEST
11. EXPANSION TEST

To execute the T6400 Diagnostic Program you will need the following :

- T6400 Diagnostic Disk (for all tests)
- Formatted working disk for the floppy disk drive test (for all tests)
- Cleaning disk kit to clean the floppy disk drive heads (for FDD Head Cleaning)
- Printer wraparound connector (34M741986G01) for the printer wraparound test (for Printer test)
- RS-232-C wraparound connector (34M741621G01) for the RS-232-C port wraparound test (for ASYNC test)
- Expansion slot wraparound board (F32BUS, F51BUS) (for expansion test)

The following sections detail the tests within the Diagnostic Test function of the Service Program Module. Refer to Sections 3.17 through 3.23 for detailed information on the remaining eight Service Program functions.

---

## 3.2 Executing the T6400 Diagnostic Program

---

Toshiba MS-DOS is required to run the T6400 Diagnostic Test. To start the T6400 Diagnostic Program, follow these steps:

1. Turn on the T6400 and allow the computer to boot. Then insert the T6400 Diagnostic Diskette in the T6400's internal floppy disk drive.
2. At the system prompt change to drive A, type **TESTCE64**, and press **Enter**.

The DIAGNOSTICS MENU will be displayed as shown below.

```
TOSHIBA personal computer T6400 DIAGNOSTICS
version x.xx (c) copyright TOSHIBA Corp. 1991
```

```
DIAGNOSTICS MENU :
```

- ```
 1 - DIAGNOSTIC TEST
 2 - HARD DISK FORMAT
 3 - SEEK TO LANDING ZONE (HDD)
 4 - HEAD CLEANING
 5 - LOG UTILITIES
 6 - RUNNING TEST
 7 - FDD UTILITIES
 8 - SYSTEM CONFIGURATION
 9 - EXIT TO MS-DOS
 0 - SETUP
```

```
PRESS [0] - [9] KEY
```

**NOTE:** To exit from the DIAGNOSTIC TEST menu, press **Ctrl + C**. To exit the T6400 Diagnostic Program and return to MS-DOS, type **9** and press **Enter**. If a test program is in progress, press **Ctrl + Break** to exit the test. If a test has not been executed, press **Ctrl + C** to return to the subtest menu. To exit any subtest menu, type **99** and press **Enter**.

3. To execute the Diagnostic Test function from the DIAGNOSTICS MENU, type **1** and press **Enter**. The following DIAGNOSTIC TEST MENU will appear.

```
TOSHIBA personal computer T6400 DIAGNOSTICS
version x.xx (c) copyright TOSHIBA Corp. 1991
```

DIAGNOSTIC TEST MENU :

- 1 - SYSTEM TEST
- 2 - MEMORY TEST
- 3 - KEYBOARD TEST
- 4 - DISPLAY TEST
- 5 - FLOPPY DISK TEST
- 6 - PRINTER TEST
- 7 - ASYNC TEST
- 8 - HARD DISK TEST
- 9 - REAL TIMER TEST
- 10 - NDP TEST
- 11 - EXPANSION TEST
- 88 - FDD & HDD ERROR RETRY COUNT SET
- 99 - EXIT TO DIAGNOSTICS MENU

PRESS [1] - [99] KEY

Diagnostic Tests 1 through 11 are discussed in Sections 3.4 through 3.14. Test menu option 88 sets the floppy disk drive and hard disk drive error retry count. Option 99 exits the DIAGNOSTIC TEST MENU and returns you to the DIAGNOSTICS MENU.

4. Select the test number you want to execute and press **Enter**. A test-specific display will appear. For example, the following display shows the System Test which appears when you type **1** and press **Enter**.

```
SYSTEM TEST                                xxxxxxxx
   T6400 DIAGNOSTIC TEST Vx.xx
   [Ctrl]+[Break] ; test end
   [Ctrl]+[C]      ; key stop

SUB-TEST   : xx
PASS COUNT: xxxxx   ERROR COUNT: xxxxx
WRITE DATA: xx READ DATA : xx
ADDRESS    : xxxxxxx STATUS      : xxx

SUB-TEST MENU :

01 - ROM checksum
02 - HW status
99 - Exit to DIAGNOSTIC TEST MENU

SELECT SUB-TEST NUMBER ?
```

*NOTE: The menu displayed by your T6400 may be slightly different from the one shown above.*

5. Enter the desired subtest number from the subtest menu and press **Enter**. The following message will appear.

**TEST LOOP (1:YES/2:NO) ?**

Selecting **Yes** increases the pass counter by one each time the test cycle ends and restarts the test cycle.

Selecting **No** returns you to the subtest menu after the test is complete.

6. Type in **1** or **2** for the Test Loop and press **Enter**. The following message will appear.

**ERROR STOP (1:YES/2:NO) ?**

Selecting **Yes** stops the test program when an error is found and displays the operation guide on the right side of the display screen as shown below.

**ERROR STATUS NAME                    [[ HALT OPERATION ]]**

**1: Test End**  
**2: Continue**  
**3: Retry**

- 1:** Terminates the test program execution and exits to the subtest menu.
- 2:** Continues the test.
- 3:** Restarts the test from the beginning of the test.

Selecting **No** displays the error status, increases the error counter by one, and resumes the test.

7. Type in **1** or **2** for the Error Stop and press **Enter** to execute the subtest chosen from the subtest menu.

Table 3-1 in Section 3.3 lists the subtests available for each test on the DIAGNOSTIC TEST MENU. Table 3-3 in Section 3.14 describes the error code and error status for each potential error.

## 3.3 Subtest Names

Table 3-1 lists the subtests for each test program in the Test Program Module (DIAGNOSTIC TEST MENU).

*Table 3-1 Subtest names*

| Test No. | Test name | Subtest No. | Subtest name                     |
|----------|-----------|-------------|----------------------------------|
| 1        | SYSTEM    | 01          | ROM checksum                     |
|          |           | 02          | HW status                        |
| 2        | MEMORY    | 01          | RAM constant data                |
|          |           | 02          | RAM address pattern data         |
|          |           | 03          | RAM refresh                      |
|          |           | 04          | Protected mode                   |
|          |           | 05          | Memory module                    |
| 3        | KEYBOARD  | 01          | Pressed key display (101)        |
|          |           | 02          | Pressed key display (102)        |
|          |           | 03          | Pressed key code display         |
|          |           | 04          | PS/2 mouse                       |
| 4        | DISPLAY   | 01          | VRAM read/write                  |
|          |           | 02          | Character attributes             |
|          |           | 03          | Character set                    |
|          |           | 04          | 80*25 Character display          |
|          |           | 05          | Graphics display (color set 0/1) |
|          |           | 06          | 640*200 Graphics display         |
|          |           | 07          | 640*400 Graphics display         |
|          |           | 08          | Display page                     |
|          |           | 09          | "H" pattern display              |
|          |           | 10          | LED/DAC pallet                   |
|          |           | 11          | TFT 512 color display            |
| 5        | FDD       | 01          | Sequential read                  |
|          |           | 02          | Sequential read/write            |
|          |           | 03          | Random address/data              |
|          |           | 04          | Write specified address          |
|          |           | 05          | Read specified address           |
| 6        | PRINTER   | 01          | Ripple pattern                   |
|          |           | 02          | Function                         |
|          |           | 03          | Wraparound                       |
| 7        | ASYNC     | 01          | Wraparound (board)               |
|          |           | 02          | Board (#1) <=> board (#2)        |
|          |           | 03          | Point to point (send)            |
|          |           | 04          | Point to point (receive)         |
|          |           | 05          | Card modem loopback (1200BPS)    |
|          |           | 06          | Interrupt test (IRQ4, 3, 5)      |



Table 3-1 Subtest names (continued)

| Test No. | Test name  | Subtest No. | Subtest name                    |
|----------|------------|-------------|---------------------------------|
| 8        | HDD        | 01          | Sequential read                 |
|          |            | 02          | Address uniqueness (uniqueness) |
|          |            | 03          | Random address/data             |
|          |            | 04          | Cross talk & peek (peak) shift  |
|          |            | 05          | Write/read/compare (CE)         |
|          |            | 06          | Write specified address         |
|          |            | 07          | Read specified address          |
|          |            | 08          | ECC circuit                     |
|          |            | 09          | Sequential write                |
|          |            | 10          | W-R-C specified address         |
| 9        | REAL TIMER | 01          | Real time                       |
|          |            | 02          | Backup memory                   |
|          |            | 03          | Real time carry                 |
| 10       | NDP        | 01          | NDP test                        |
| 11       | EXPANSION  | 01          | Box wraparound                  |
|          |            | 02          | Box mono video-RAM              |
|          |            | 03          | Wraparound (51-bus)             |
|          |            | 04          | Wraparound (32-bus)             |

---

## 3.4 System Test

---

To execute the System Test, type **1** from the DIAGNOSTIC TEST MENU, press **Enter**, and follow the directions displayed on the screen. The System Test contains two subtests that test the ROM checksum and the Hardware Status of the T6400. Typing **1** and pressing **Enter** executes the ROM checksum test. Typing **2** and pressing **Enter** executes the HW status test.

Subtest 01 ROM checksum

This subtest tests the T6400's system board from address F0000h - FFFFFh (64KB).

Subtest 02 HW status

This subtest reads and displays the T6400's hardware status as shown below.

```

                          76543210
H/W status = 10101000

Bit7 -
Bit6 -
Bit5 - Notch signal = 2DD
Bit4 - FDD type     = 2MB
Bit3 -              =
Bit2 - Drive A/B   = B
Bit1 - External FDD = OFF
Bit0 -
```

Press **Ctrl + Break** to return to the SYSTEM TEST menu.

Table 3-2 describes the hardware bit status for each bit tested.

*Table 3-2 T6400 hardware bit status*

| Bit | H/W status   | 1    | 0    |
|-----|--------------|------|------|
| 7   | Reserved     | --   | --   |
| 6   | Reserved     | --   | --   |
| 5   | Media type   | 2DD  | 2HD  |
| 4   | FDD type     | 1 MB | 2 MB |
| 3   | Reserved     | --   | --   |
| 2   | Drive A/B    | A    | B    |
| 1   | External FDD | ON   | OFF  |
| 0   | Reserved     | --   | --   |

---

## 3.5 Memory Test

---

To execute the Memory Test , type **2** from the DIAGNOSTIC TEST MENU, press **Enter**, and follow the directions displayed on the screen. The Memory Test contains five subtests that test the following T6400 memories: RAM constant data, RAM address pattern data, RAM refresh (real mode), protected mode, and memory module. Select the number corresponding to the subtest you want to execute and press **Enter**.

### Subtest 01 RAM Constant Data

This subtest writes constant data FFFFh, AAAAh, 5555h, 0101h, and 0000h to conventional memory (0 to 640KB). The constant data is then read from conventional memory and compared to the original data.

### Subtest 02 RAM Address Pattern Data

This subtest writes address pattern data created by eXclusive-ORing (XORing) to the address segment and address offset in conventional memory (0 to 640KB). The address pattern data is then read from conventional memory and compared to the original data.

### Subtest 03 RAM Refresh (Real Mode)

This subtest writes a 256-byte unit of constant data (AAAAh and 5555h) to conventional memory (0 to 640KB). This data is then read from conventional memory and compared to the original data.

**NOTE:** *The size of the data being read and written to conventional memory causes a short delay between write and read operations.*

### Subtest 04 Protected Mode

This subtest writes constant data FFh, AAh, 55h, 00h and address data to extended memory (addressed 100000h to the maximum address). The data is then read from extended memory and compared to the original data.

Subtest 05 Memory Module

**NOTE:** *To execute the this subtest, an optional memory card must be installed in the T6400.*

This subtest is the same as subtest 04, and is used to test an optional memory card. Memory modules for the T6400 are available in 2MB, 4MB, and 8MB capacities.

When you select Subtest 05 the following message appears.

**Extended memory size (1:2 MB,2:4 MB,3:8 MB) ?**

Select the number that corresponds to the memory card capacity installed in the T6400.

---

## 3.6 Keyboard Test

---

To execute the Keyboard Test, type **3** from the DIAGNOSTIC TEST MENU, press **Enter**, and follow the directions displayed on the screen. The Keyboard Test contains four subtests that test the T6400's keyboard actions. Select the number corresponding to the subtest you want execute and press **Enter**.

Subtest 01, 02 Pressed Key Display (101/102)

***NOTE:** The **Num Lock** key must be off to execute these two subtests.*

When you execute the Pressed Key Display Test, the keyboard layout is drawn on the display as shown below. When any key is pressed, the corresponding key on the screen changes to an "\*" (asterisk) character. Holding a key down enables the auto-repeat function which causes the key's display character to blink.

KEYBOARD TEST            IN PROGRESS            301000

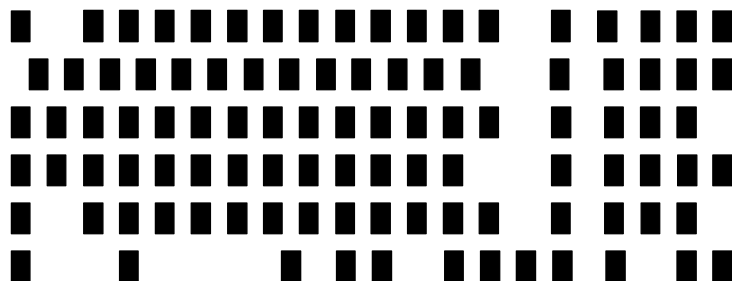

[Print:Alt+SysReq, Pause:Ctrl+Break]  
IF TEST OK, PRESS [DEL] THEN [ENTER] KEY

Subtest 03    Pressed Key Code Display

When a key is pressed, the scan code, character code, and key top name are displayed on the screen in the format shown below. The **Ins**, **Caps Lock**, **Num Lock**, **Scroll Lock**, **Alt**, **Ctrl**, **Left Shift**, and **Right Shift** keys are displayed in reverse video when pressed. The scan codes, character codes, and key top names are listed in Appendix D.

```
KEYBOARD TEST            IN PROGRESS            302000

                  Scan code            =

                  Character code       =

                  Keytop                =

Ins Lock    Caps Lock    Num Lock    Scroll Lock

Alt         Ctrl            Left Shift    Right Shift

PRESS [ENTER] KEY
```

Subtest 04    PS/2 Mouse

This subtest tests the connection of the PS/2 mouse communication line.

---

## 3.7 Display Test

---

To execute the T6400 Display Test, type **4** from the DIAGNOSTIC TEST MENU, press **Enter**, and follow the directions displayed on the screen. The Display Test contains eleven subtests that test the T6400's display in various modes. Select the number corresponding to the subtest you want execute and press **Enter**.

### Subtest 01 VRAM Read/Write

This subtest writes constant data FFFFh, AAAAh, 5555h, 0000h, and address data to video RAM (256KB). This data is then read from the video RAM and compared to the original data.

### Subtest 02 Character Attributes (Mode 1 and 13h)

This subtest displays the following character attribute modes: normal, intensified, reverse, and blinking as shown in the display below. The character attribute modes display the foreground color and intensified color (16 colors or 16 levels of gray) using black, blue, red, magenta, green, cyan, yellow, and white from the color display. The display below appears on the screen when this subtest is executed.

#### CHARACTER ATTRIBUTES

NEXT LINE SHOWS NORMAL DISPLAY.

NNNNNNNNNNNNNNNNNNNNNNNNNNNNNNNNNNNN

NEXT LINE SHOWS INTENSIFIED DISPLAY.

IIIIIIIIIIIIIIIIIIIIIIIIIIIIIIIIIIIIII

NEXT LINE SHOWS REVERSE DISPLAY.

RRRRRRRRRRRRRRRRRRRRRRRRRRRRRRRRRR

NEXT LINE SHOWS BLINKING DISPLAY

BBBBBBBBBBBBBBBBBBBBBBBBBBBBBBBBBB

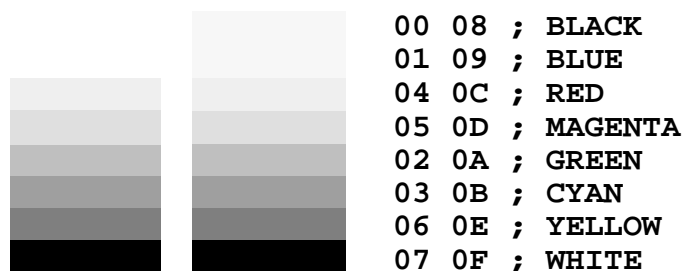

PRESS [ENTER] KEY

Press **Ctrl + Break** to return to the DISPLAY TEST menu.





Subtest 05 Graphics Display (Color set 0/1)

This subtest displays three of the color sets for the color display in the 320x200 dots graphics mode 4 and D as shown below.

320\*200 GRAPHICS DISPLAY  
COLOR SET X : [X]



PRESS [ENTER] KEY

Press **Ctrl + Break** to return to the DISPLAY TEST menu.

Subtest 06 640x200 Graphics Display

This subtest displays the even dots, odd dots, and all dots block in the 640x200 dots graphics mode 6 and E as shown below.

640\*200 GRAPHICS DISPLAY : [X]  
EVEN DOTS            ODD DOTS            ALL DOTS  
DRIVEN                DRIVEN                DRIVEN

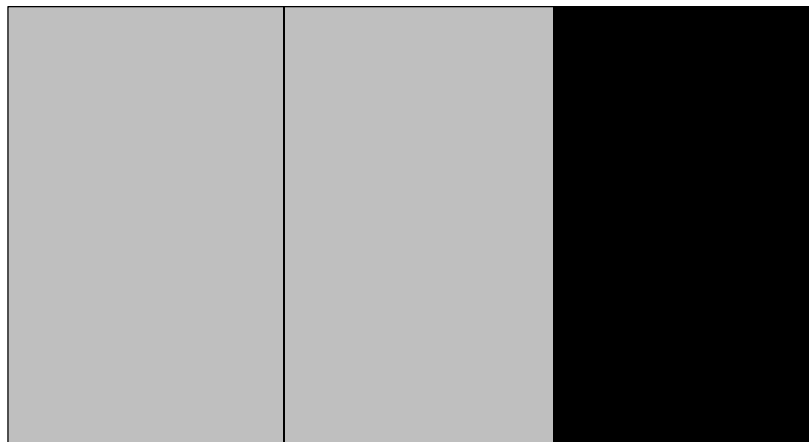

PRESS [ENTER] KEY

Press **Ctrl + Break** to return to the DISPLAY TEST menu.



Subtest 09 H Pattern Display

This subtest displays 2,000 H characters on the entire screen, as shown below.

```
HH
HH
HH
HH
HH
HH
HH
HH
HH
HH
HH
HH
HH
HH
```

Press **Ctrl + Break** to return to the DISPLAY TEST menu.

Subtest 10 LED/DAC Pallet

This subtest checks the Caps Lock and Num Lock key operations by writing 2Ah/15h data to 6 bits of 256x3 (RGB). This data is then read and compared to the original data.

```
[ Caps/Num/Scroll LED test ]
(1) Press [ Caps Lock ] key !...Caps (on/off)
(2) Press [ Num lock ] key !...Num (on/off)
(3) Press [ Scroll lock] key !...Scroll (on/off)
PRESS [ENTER] KEY
```

Press **Enter** to display the following message.

```
[DAC pallet W-R-CMP start] = OK
[Processor latch test] =
Processor lachtest (1:256 times, 2:endless) ?
```

Press **Ctrl + Break** to return to the DISPLAY TEST menu.

Subtest 11 TFT 512 Color Display

This subtest displays 512 shades of red, green, and blue on the T6400's display.

Press **Ctrl + Break** to return to the DISPLAY TEST menu.

---

## 3.8 Floppy Disk Test

---

**CAUTION:** Before running the Floppy Disk Test, prepare a formatted work disk. Remove the Diagnostic Disk and insert the work disk into the FDD. The contents of the floppy disk will be erased.

To execute the Floppy Disk Test, type **5** from the DIAGNOSTIC TEST MENU, press **Enter**, and follow the directions displayed on the screen. The Floppy Disk Test contains five subtests that test the T6400's internal floppy disk drive. The following messages will appear after selecting the Floppy Disk Test from the DIAGNOSTIC TEST MENU. Answer each of the following questions with an appropriate response to execute the test.

1. Select the drive number of the floppy disk drive to be tested and press **Enter**.

**Test drive number select (1:FDD#1,2:FDD#2,0:FDD1&2) ?**

2. Select the media type of the floppy disk in the drive to be tested and press **Enter**.

**Media in drive#x mode (0:2DD,1:2D,2:2D-2HD/2DD,3:2HD) ?**

3. Select the track you want the test to start on and press **Enter**. Simply pressing **Enter** sets the start track at zero.

**Test start track (Enter:0/dd:00-79) ?**

4. The FLOPPY DISK TEST menu will appear after you select the start track number. Select the number of the subtest you want to execute and press **Enter**. The following message will appear during each subtest.

```
FLOPPY DISK                                xxxxxxxx

SUB-TEST   : xx
PASS COUNT: xxxxxx      ERROR COUNT: xxxxxx
WRITE DATA: xx         READ DATA  : xx
ADDRESS    : xxxxxx     STATUS      : xxx
```

The first three digits in the **ADDRESS** number indicate which cylinder is being tested. The fourth digit indicates the head, and the last two digits indicate the sector being tested.

The first digit in the **STATUS** number indicates the drive being tested and the last two digits indicate the error code as explained in Table 3-3.

Subtest 01 Sequential Read

This subtest performs a Cyclic Redundancy Check (CRC), that continuously reads all the tracks on a floppy disk. The following tracks are read according to the media type in the floppy disk drive:

Double-sided, double-density (2D): Track 0 to 39.

Double-sided, double-density, double-track (2DD) and double-sided, high-density, double-track (2HD): Track 0 to 79.

The start track is specified when the Floppy Disk Test is selected from the DIAGNOSTIC TEST MENU. Refer to step 3 at the beginning of this section to set the start track.

Subtest 02 Sequential Read/Write

This subtest continuously writes the bad data pattern B5ADADh to all the tracks as specified in Subtest 01. The data is then read and compared to the original data.

Subtest 03 Random Address/Data

This subtest writes random data to random addresses on all tracks defined in Subtest 01. The data is then read and compared to the original data.

Subtest 04 Write Specified Address

This subtest writes the specified data to a specified track, head, and address.

Subtest 05 Read Specified Address

This subtest reads the data from a specified track, head, and address.

---

## 3.9 Printer Test

---

To execute the Printer Test, type **6** from the DIAGNOSTIC TEST MENU, press **Enter**, and follow the directions displayed on the screen. The Printer Test contains three subtests that test the printer output from the T6400. The following message will appear after selecting the Printer Test from the DIAGNOSTIC TEST MENU. Answer the following question with an appropriate response to execute the test.

**CAUTION:** An IBM compatible printer must be connected to the system to execute this test. Make sure the setup option **External FDD/PRT** is set to **Printer**.

The following message will appear when the Printer Test is selected.

```
channel#1 = xxxxh
channel#2 = xxxxh
channel#3 = xxxxh
Select the channel number (1-3) ?
```

The printer I/O port address is specified by the **xxxxh** number. The T6400 supports three printer channels. Select the printer channel number and press **Enter** to execute the selected subtest.

### Subtest 01 Ripple Pattern

This subtest prints characters for codes 20h through 7Eh line by line while shifting one character to the left at the beginning of each new line.

```
!"#$%&'()*+,-./0123456789:;<=>?@ABCDEFGHIJKLMN OPQRSTUVWXYZ[\]^_`abcdefghijklmnop
!"#$%&'()*+,-./0123456789:;<=>?@ABCDEFGHIJKLMN OPQRSTUVWXYZ[\]^_`abcdefghijklmnop
!"#$%&'()*+,-./0123456789:;<=>?@ABCDEFGHIJKLMN OPQRSTUVWXYZ[\]^_`abcdefghijklmnop
!"#$%&'()*+,-./0123456789:;<=>?@ABCDEFGHIJKLMN OPQRSTUVWXYZ[\]^_`abcdefghijklmnop
!"#$%&'()*+,-./0123456789:;<=>?@ABCDEFGHIJKLMN OPQRSTUVWXYZ[\]^_`abcdefghijklmnopqr
!"#$%&'()*+,-./0123456789:;<=>?@ABCDEFGHIJKLMN OPQRSTUVWXYZ[\]^_`abcdefghijklmnopqr
!"#$%&'()*+,-./0123456789:;<=>?@ABCDEFGHIJKLMN OPQRSTUVWXYZ[\]^_`abcdefghijklmnopqrs
!"#$%&'()*+,-./0123456789:;<=>?@ABCDEFGHIJKLMN OPQRSTUVWXYZ[\]^_`abcdefghijklmnopqrst
!"#$%&'()*+,-./0123456789:;<=>?@ABCDEFGHIJKLMN OPQRSTUVWXYZ[\]^_`abcdefghijklmnopqrstu
!"#$%&'()*+,-./0123456789:;<=>?@ABCDEFGHIJKLMN OPQRSTUVWXYZ[\]^_`abcdefghijklmnopqrstuv
```

## Subtest 02    Function

This subtest prints out the various print types shown below:

```
PRINTER TEST
1.        THIS LINES SHOWS NORMAL PRINT.
2.        THIS LINE SHOWS DOUBLE WIDTH PRINT.
3.        THIS LINE SHOWS COMPRESSED PRINT.
4.        THIS LINE SHOWS EMPHASIZED PRINT.
5.        THIS LINE SHOWS DOUBLE STRIKE PRINT.
6.        ALL CHARACTERS PRINT
!"#$%&'()*+,-./0123456789:;<=>?@ABCDEFGHIJKLMNopqrstuvwxyz[\]^_`abcdefghijklmnopqrstuvwxyz{|}~
```

## Subtest 03    Wraparound

***NOTE:*** To execute this subtest a printer wraparound connector must be connected to the T6400's printer port. The printer wraparound connector (34M741986G01) wiring diagram is described in Appendix F.

This subtest checks the output and bi-directional modes of the data control and status lines through the printer wraparound connector.

---

## 3.10 ASYNC Test

---

To execute the ASYNC Test, type **7** from the DIAGNOSTIC TEST MENU, press **Enter**, and follow the directions displayed on the screen. The ASYNC Test contains six subtests that test the T6400's asynchronous communication functions.

Subtests 01 through 04 require the following data format:

Method: Asynchronous  
Speed: 9600 BPS  
Data: 8 bits and one parity bit (EVEN)  
Stop bit: One stop bit  
Data pattern: 20h to 7Eh

The following message will appear when Subtests 01, 03, 04, or 05 are selected.

```
channel#1 = xxxxh  
channel#2 = xxxxh  
channel#3 = xxxxh  
Select the channel number (1-3)
```

The serial I/O port address is specified by the **xxxxh** number.

The T6400 supports three serial port channels. Select the serial port channel number and press **Enter** to execute the selected subtest.

Subtest 01 Wraparound (board)

**NOTE:** To execute this subtest an RS-232-C wraparound connector (34M741621G01) must be connected to the RS-232-C port. The RS-232-C wraparound connector wiring diagram is described in Appendix F.

This subtest checks the data send/receive function through the wraparound connector.

Subtest 02 Board (#1) <=> board (#2)

**NOTE:** To execute this subtest an RS-232-C cable (9-pin to 9-pin) must be connected to channels 1 and 2. The RS-232-C direct cable wiring diagram is described in Appendix F.

This subtest checks the data send/receive function through the RS-232-C direct cable.



~~Subtest 03 Point to Point (Send)~~

***NOTE:** To execute this subtest, two machines must be connected with an RS-232-C direct cable. One machine should be set as 'send' (Subtest 03) and the other set as 'receive' (Subtest 04). The wiring diagram for the RS-232-C direct cable is described in Appendix F.*

This subtest sends 20h through 7Eh data to the receive side, then receives the data back and compares it to the original data.

Subtest 04 Point to Point (Receive)

This subtest is used with Subtest 03 described above. This subtest receives the data from the send side, then returns the data.

~~Subtest 05 Card Modem Loopback (1200BPS)~~

***NOTE:** To execute this subtest, a built-in modem must be installed.*

This subtest sends data from the RS-232-C port to the built-in modem. The same data is then sent from the modem to the RS-232-C port and compared to the original data.

When you select the channel number of the serial port and press **Enter**, the following message appears.

**Baud rate select (0:110BPS, 1:300BPS, 2:1200BPS) ?**

Select the baud rate for the serial port and press **Enter** to execute this subtest.

Subtest 06 Interrupt Test (IRQ 4, 3, and 5)

This subtest checks the Interrupt Request Levels of IRQ 4, 3, and 5 from the send side.

---

## 3.11 Hard Disk Test

To execute the Hard Disk Test, type **8** from the DIAGNOSTIC TEST MENU, press **Enter**, and follow the directions displayed on the screen. The Hard Disk Test contains ten subtests that test the T6400 hard disk drive functions. The following messages will appear after selecting the Hard

DISK TEST from the DIAGNOSTIC TEST MENU. Answer each of the following questions with an appropriate response to execute the test.

*CAUTION: The contents of the hard disk will be erased when Subtest 02, 03, 04, 05, 06,*

*08, 09, or 10 is executed. Before running the test, transfer the contents of the hard disk to a floppy disk(s). This can be done with the Toshiba MS-DOS BACKUP command.*

After the test, execute the Toshiba MS-DOS FDISK command, which will partition the hard disk. Then execute the Toshiba MS-DOS FORMAT command. Refer to the Toshiba MS-DOS manual for details.

1. When you select the Hard Disk Test from the DIAGNOSTIC TEST MENU, the following message will appear.

**Test drive number select (1:HDD#1,2:HDD#2,0:HDD1&2) ?**

2. Select the hard disk drive number to be tested and press **Enter**. The following message will appear.

**HDC F/W error retry (1:yes,2:no) ?**

3. This message is used to select the retry operation when the hard disk controller detects an error. Type **1** or **2** and press **Enter**. The following message will appear.

**Data compare error dump (1:no,2:yes) ?**

4. This message is used to select the error dump operation when a data compare error is detected. Type **1** or **2** and press **Enter**. The following message will appear.

**Detail status display (1:no,2:yes) ?**

5. This message is used to select whether or not the HDD status is displayed on the screen.

The HDD status is described in Section 3.15. Type **1** or **2** and press **Enter**.

6. The HARD DISK TEST menu will appear after you respond to the detail status prompt. Select the number for the subtest you want to execute and press **Enter**. The following message will appear during each subtest.

```
HARD DISK TEST                                xxxxxxxx

SUB-TEST:   xx
PASS COUNT: xxxxxx          ERROR COUNT: xxxxxx
WRITE DATA: xx           READ DATA:   xx
ADDRESS:    xxxxxxxxxx     STATUS:     xxx
```

The first four digits of the **ADDRESS** number indicate which cylinder is being tested, the fifth and sixth digits indicate the head, and the last two digits indicate the sector.

The first digit of the **STATUS** number indicates the drive being tested and the last two digits indicate the error code as explained in Table 3-3.

Subtest 01 Sequential Read

This subtest is a sequential reading of all the tracks on the HDD starting at track 0. When all the tracks on the HDD have been read, the test starts at the maximum track and reads the tracks on the HDD sequentially back to track 0.

Subtest 02 Address Uniqueness (Uniqueness)

This subtest writes unique address data to each sector of the HDD track by track. The data written to each sector is then read and compared with the original data. There are three ways the HDD can be read:

- Forward sequential
- Reverse sequential
- Random

Subtest 03 Random Address/Data

This subtest writes random data to random addresses (cylinder, head, and sector) on the HDD. This data is then read and compared to the original data.

Subtest 04 Cross Talk & Peek (Peak) Shift

This subtest writes eight types of the worst pattern data (shown below) to a cylinder, then reads the data while moving from cylinder to cylinder.

Worst pattern data:

B5ADADh, 4A5252h, EB6DB6h, 149249h,  
63B63Bh, 9C49C4h, 2DB6DBh, D24924h

Subtest 05 Write/Read/Compare (CE)

This subtest writes the worst pattern data (B5ADADh ) to the CE cylinder on the HDD, then reads the data from the CE cylinder and compares it with the original data.

Subtest 06 Write Specified Address

This subtest writes specified data to a specified cylinder and head on the HDD.

Subtest 07 Read Specified Address

This subtest reads data which has been written to a specified cylinder and head on the HDD.

Subtest 08 ECC Circuit

This subtest checks the Error Check and Correction (ECC) circuit functions of the specified cylinder and head on the HDD.

Subtest 09 Sequential Write

This subtest writes specified 2-byte data to all of the cylinders on the HDD.

Subtest 10 W-R-C Specified Address

---

This subtest writes data to a specified cylinder and head on the HDD, then reads the data and compares it with the original data.

---

## 3.12 Real Timer Test

To execute the Real Timer Test, type **8** from the DIAGNOSTIC TEST MENU, press **Enter**, and follow the directions on the screen. The Real Timer Test contains three subtests that test the T6400's real timer functions.

### Subtest 01 Real Time

A new date and time can be inputted during this subtest. To execute the Real Time Subtest follow these steps:

1. Select Subtest 01 and the following message will appear.

**Current date : xx-xx-xxxx**

**Current time : xx:xx:xx**

**Enter new date:**

**PRESS [ENTER] KEY TO EXIT TEST**

2. If the current date is not correct, input the correct date at the prompt and press **Enter**. The following prompt will appear.

**Enter new time :**

3. If the current time is not correct, input the correct time (in military format). After pressing **Enter** you return to the REAL TIMER TEST menu.

### Subtest 02 Backup Memory

This subtest performs the following backup memory checks:

- Writes 1-bit of "on" data to addresses 01h through 80h
- Writes 1-bit of "off" data to addresses FEh through 7Fh
- Writes the data pattern AAh through 55h to the RTC 50 bytes backup memory (addressed 0Eh to 3Fh).

~~Then the subtest reads and compares this data with the original data.~~

~~Subtest 02 Real Time Copy~~

**CAUTION:** When this subtest is executed, the current date and time are erased.

This subtest checks the real time clock increments, making sure the date and time are displayed in the following format:

---

(month, day, year, hour, minute, and second)

---

## 3.13 Numeric Data Processor Test

*NOTE: To execute this test, the 80486SX CPU must be changed to an 80486DX CPU.*

### Subtest 01 NDP test

This subtest checks the following functions of the numeric data processor:

- Control word
- Status word
- Bus
- Addition
- Multiplication

This test determines whether or not an NDP is installed by sending one bit of “on” data to the NDP. If the test determines that an NDP is installed, the test is executed.

---

This test also determines if the CPU is a 486SX without an NDP or a DX with the NDP. If the 486SX is installed, the test isn't executed. If the 486DX is installed, the test is executed.

---

## 3.14 Expansion Unit Test

*NOTE: If an expansion unit is not connected to the system, this test cannot be executed.*

### Subtest 01 Box Wraparound

*NOTE: To execute this subtest, a wraparound board must be installed in the expansion unit.*

The following tests are executed.

- Clock test (LSC, CLK, ALE)
- Interrupt test (IRQ3, 5)
- DMA test (channel #1, 3 or TC status)
- Data bus test (00h - FFh)
- Address bus test (A0000h - AFFFFh)
- Wait CNT test

### Subtest 02 Box Mono Video - RAM

*NOTE: To execute this subtest, a monochrome display card must be installed in the expansion unit.*

This subtest writes data (FFh, AAh, 55h, 00h) into the monochrome display memory (B0000h to B0F9Fh), then reads the data out and compares it with the original data.

### Subtest 03 Wraparound Test (51-bus)

*NOTE: To execute this subtest, a wraparound board must be installed in the expansion unit.*

The following tests are executed.

- Clock test (OSC, CLK, ALE, DACK0)
- Interrupt test (IRQ7-3, IRQ14, IRQ12-9)
- DMA #1 test (channel 1...3, or TC status)
- Data bus test (00h-FFh)
- Address bus test (C0000h-CFFFFh)
- Memory W/R test
- IO16 test
- MASTER test

- DMA #2 test (channel 5, 6)
- CCMCS test
- MDSPK test (buzzer)
- A17-23 test (B80000h, B40000h)

Subtest 04    Wraparound Test (32-bus)

***NOTE:** To execute this subtest, a wraparound board must be installed in the expansion unit.*

The following tests are executed.

- Clock test (OSC, CLK, ALE, DACK0)
- Interrupt test (IRQ7-3, IRQ14, IRQ12-9)
- DMA #1 test (channel 1...3, or TC status)
- Data bus test (00h-FFh)
- Address bus test (C0000h-CFFFFh)



- 
- Memory W/R test
  - IO16 test
- 
- MASTER test
  - DMA #2 test (channel 5, 6)
  - -12, +12, -5V test
  - A17-23 test (B80000h, B40000h)

| <b>Device name</b> | <b>Error code</b> | <b>Error status name</b>  |
|--------------------|-------------------|---------------------------|
| (COMMON)           | FF                | Data Compare Error        |
| SYSTEM             | 01                | ROM Checksum Error        |
| MEMORY             | 01                | Parity Error              |
|                    | 02                | Protected Mode Not Change |
| FDD                | 01                | Bad Command               |
|                    | 02                | Address Mark Not Found    |
|                    | 03                | Write Protected           |
|                    | 04                | Record Not Found          |
|                    | 06                | Media Removed             |
|                    | 08                | DMA Overrun Error         |
|                    | 09                | DMA Boundary Error        |
|                    | 10                | CRC Error                 |
|                    | 20                | FDC Error                 |
|                    | 40                | Seek Error                |
|                    | 60                | FDD Not Drive             |
| PRINTER            | 80                | Time Out Error            |
|                    | EE                | Write Buffer Error        |
|                    | 01                | Time Out                  |
|                    | 08                | Fault                     |
|                    | 10                | Select Line               |
|                    | 20                | Out Of Paper              |
| 40                 | Power Off         |                           |
| 80                 | Busy Line         |                           |

## 3.15 Error Code and Error Status Names

| Device name | Error code      | Error status name         |
|-------------|-----------------|---------------------------|
| ASYNC       | 01              | DSR On Time Out           |
|             | 02              | CTS On Time Out           |
|             | 04              | RX-ENABLE Time Out        |
|             | 08              | TX-BUFFER Full Time Out   |
|             | 10              | Parity Error              |
|             | 20              | Framing Error             |
|             | 40              | Overrun Error             |
|             | 80              | Line Status Error         |
|             | 88              | Modem Status Error        |
|             | 33              | NO CARRIER (Card Modem)   |
|             | 34              | ERROR (Card Modem)        |
|             | 36              | NO DIAL TONE (Card Modem) |
| HDD         | 01              | Bad Command Error         |
|             | 02              | Bad Address Mark Error    |
|             | 04              | Record Not Found          |
|             | 05              | HDC Not Reset             |
|             | 07              | Drive Not Initialize      |
|             | 09              | DMA Boundary Error        |
|             | 0A              | Bad Sector                |
|             | 0B              | Bad Track Error           |
|             | 10              | ECC Error                 |
|             | 11              | ECC Recover Enable        |
|             | 20              | HDC Error                 |
|             | 40              | Seek Error                |
|             | 80              | Time Out Error            |
|             | AA              | Drive Not Ready           |
|             | BB              | Undefined                 |
|             | CC              | Write Fault               |
| E0          | Status Error    |                           |
| F0          | Not sense error |                           |
| NDP         | 01              | No CO-PROCESSOR           |
|             | 02              | Control Word Error        |
|             | 03              | Status Word Error         |
|             | 04              | Bus Error                 |
|             | 05              | Addition Error            |
|             | 06              | Multiple Error            |

---

Table 3-3 lists the error codes and error status names for the Diagnostic Test.

*Table 3-3 Error codes and error status names*  
*Table 3-3 Error codes and error status names (continued)*

## 3.16 Hard Disk Test Detail Status

When an error occurs in the Hard Disk Test, the following message is displayed:

```
HDC status = xxxxxxxx
```

Detailed information about the Hard Disk Test error is displayed on the screen by an eight-digit number. The first four digits represent the hard disk controller (HDC) error status number and the last four digits are not used.

The HDC error status is composed of 2 bytes; the first byte displays the contents of the HDC status register in hexadecimal form and the second byte displays the HDC error register.

| Bit | Name                         | Description                                                                                                              |
|-----|------------------------------|--------------------------------------------------------------------------------------------------------------------------|
| 7   | BSY<br>(Busy)                | "0"--HDC is busy.<br>"1"--HDC is ready.                                                                                  |
| 6   | DRDY<br>(Drive ready)        | "0"--Hard disk drive is not ready to accept any command.<br>"1"--Hard disk drive is ready.                               |
| 5   | DWF<br>(Drive write fault)   | "0"--DWF error is not detected.<br>"1"--Write fault condition occurs.                                                    |
| 4   | DSC<br>(Drive seek complete) | "0"--The hard disk drive heads are not settled over a track.<br>"1"--The hard disk drive heads are settled over a track. |
| 3   | DRQ<br>(Data request)        | "0"--Drive is not ready to transfer data.<br>"1"--Drive is ready for data transfer.                                      |
| 2   | CORR<br>(Corrected data)     | "0"--Otherwise.<br>"1"--Correctable data error is corrected.                                                             |
| 1   | IDX<br>(Index)               | "0"--Otherwise.<br>"1"--Index is sensed.                                                                                 |
| 0   | ERR<br>(Error)               | "0"--Otherwise.<br>"1"--The previous comand was terminated with some error.                                              |

The contents of the HDC status register and error register are described in Tables 3-4 and 3-5.

| <b>Bit</b> | <b>Name</b>              | <b>Description</b>                                                                                                                            |
|------------|--------------------------|-----------------------------------------------------------------------------------------------------------------------------------------------|
| 7          | BBK<br>(Bad block mark)  | "0"--Otherwise.<br>"1"--A bad block mark is detected.                                                                                         |
| 6          | UNC<br>(Uncorrectable)   | "0"--There is no uncorrectable data error.<br>"1"--Uncorrectable data error has been detected.                                                |
| 5          | ----                     | Not used.                                                                                                                                     |
| 4          | IDNF<br>(Identification) | "0"--Otherwise.<br>"1"--There was no ID field in the requested sector.                                                                        |
| 3          | ----                     | Not used.                                                                                                                                     |
| 2          | ABRT<br>(Abort)          | "0"--Otherwise.<br>"1"--Illegal command error or a drive status error occurs.                                                                 |
| 1          | TK09<br>(Track 0)        | "0"--The hard disk has found track 0 during a recalibrate command.<br>"1"--The hard disk could not find track 0 during a recalibrate command. |
| 0          | ----                     | Not used.                                                                                                                                     |

---

Table 3-4 HDC status register contents

Table 3-5 HDC Error register contents

## 3.17 Hard Disk Format

This function executes the hard disk formatting command. There are two types of hard disk formatting:

- Low level (physical) formatting
- MS-DOS (logical) formatting

This Hard Disk Format function performs a low level format of the hard disk and executes the following hard disk formats and check:

- |                                                                                                                                                         |
|---------------------------------------------------------------------------------------------------------------------------------------------------------|
| <ol style="list-style-type: none"><li>1. All track FORMAT</li><li>2. Good track FORMAT</li><li>3. Bad track FORMAT</li><li>4. Bad track CHECK</li></ol> |
|---------------------------------------------------------------------------------------------------------------------------------------------------------|

**CAUTION:** *The contents of the hard disk will be erased when this program is executed. Before executing the program, transfer the contents of the hard disk onto a floppy disk(s). This can be done with the Toshiba MS-DOS BACKUP command. See the Toshiba MS-DOS manual for details.*

### 3.17.1 Function Description

- |                                                                     |
|---------------------------------------------------------------------|
| <ol style="list-style-type: none"><li>1. All track FORMAT</li></ol> |
|---------------------------------------------------------------------|

This option performs a low level format of all the tracks on the hard disk as shown in Table

| Item                | Description |            |
|---------------------|-------------|------------|
|                     | 120MB       | 200MB      |
| Sector sequences    | 1           | 1          |
| Cylinders           | 0 to 1,521  | 0 to 1,096 |
| Heads               | 0 to 3      | 0 to 3     |
| Sectors             | 1 to 39     | 1 to 49    |
| Sector length (bps) | 512         | 512        |

3-6 below.

**NOTE:** Before executing the All track *FORMAT* program, execute the Bad track *CHECK* program to display a list of bad tracks on the HDD.

Table 3-6 Hard disk formatting sequence

2. Good track *FORMAT*

This option formats a specified cylinder and track as a good track. If a good track is formatted as a bad track, use this option to change the track to a good track.

3. Bad track *FORMAT*

This option formats a specified cylinder and track as a bad track. If a bad track is detected, use this option to label it as a bad track.

4. Bad track *CHECK*

This option searches the hard disk for bad tracks by reading data to all of the tracks on the hard disk. A list of bad tracks is displayed when the program is completed. If an error other than a bad track is detected, the program is automatically terminated.

### 3.17.2 Operations

**CAUTION:** After the HDD has been formatted, execute the Toshiba MS-DOS *FDISK* command to partition the HDD. Next, execute the Toshiba MS-DOS *FORMAT* command. Refer to the Toshiba MS-DOS manual for more information about using these commands.

1. Select the HARD DISK *FORMAT* function by typing **2** and pressing **Enter** from the DIAGNOSTICS MENU. The following messages appears.

```
DIAGNOSTICS - HARD DISK FORMAT : Vx.xx
```

```
1 - All track FORMAT
2 - Good track FORMAT
3 - Bad track FORMAT
4 - Bad track CHECK
9 - Exit to DIAGNOSTICS MENU
```

```
Press [NUMBER] key ?
```

2. All track *FORMAT* option

- (1) Selecting the All track FORMAT option displays the following message.

**Drive number select (1:#1,2:#2) ?**

- (2) Select a drive number and press **Enter**. The following message will appear.

**Interleave number (1/1-8) ?**

- (3) Select an interleave number (usually 1) and press **Enter**. The following message will appear.

**Unlock Format select (1:no,2:yes) ?**

- (4) Select whether or not the HDD has an unlock format and press **Enter**. If the computer contains a JVC HDD, select **yes**. If the computer contains a Conner HDD, select **no**.

The following message will appear.

```
[ HDD TYPE ] : CYLINDER = xxxx
[ HDD TYPE ] : HEAD      = xx
[ HDD TYPE ] : SECTOR   = xx
```

```
[ WARNING : Current DISK data will be
              completely destroyed ]
```

**Press [Bad track number (CCCCHH)] key ?**

- (5) Enter the cylinder and head number of the bad tracks on the HDD and press **Enter**. The cylinder number is represented by CCCC and HH is the head number. If the HDD does not have any bad tracks, press **Enter**. The **[[cylinder, head = xxxx xx]]** message will appear and all the cylinders in the hard disk will be formatted and checked.
- (6) After formatting the hard disk, execute the verify check program by pressing **Enter**. When the verify check program is complete, the following message will appear:

**Format complete**

- (6) Press **Enter** to return to the HARD DISK FORMAT menu.

### 3. Good track FORMAT or Bad track FORMAT option

- (1) When the Good track FORMAT or Bad track FORMAT option is selected, the following message will appear.

Drive number select (1:#1,2:#2) ?

- (2) Select a drive number and press **Enter**. The following message will appear.

Interleave number (1/1-8) ?

- (3) Select an interleave number (usually 1) and press **Enter**. The following message will appear.

```
[ HDD TYPE ] : CYLINDER = xxxx
[ HDD TYPE ] : HEAD     = xx
[ HDD TYPE ] : SECTOR  = xx
```

Press [Track number (CCCCHH) key ?

- (4) Type the four-digit track number and press **Enter**. The first three digits are the cylinder number and the last digit is the head number. This formats either good tracks or bad tracks as selected.

*NOTE: This function can format only one track per operation. Repeat the operation as many times as necessary to format several good tracks or bad tracks.*

- (5) After a track on the hard disk has been formatted, the following message will be displayed.

Format complete

- (6) Press **Enter** to return to the HARD DISK FORMAT menu.

#### 4. Bad track CHECK option

- (1) When this option is selected, the following message will appear.

Drive number select (1:#1,2:#2) ?

- (2) Select a drive number and press **Enter**. The following message will appear.

Interleave number (1/1-8) ?

- (3) Select an interleave number (usually 1) and press **Enter**. The following message is displayed, and the bad tracks on the hard disk are checked.

```
[ HDD TYPE ] : CYLINDER = xxxx
[ HDD TYPE ] : HEAD     = xx
[ HDD TYPE ] : SECTOR  = xx

[[cylinder, head = xxxx xx]]
```



- 
- (4) After checking the bad tracks on the hard disk, the following message will appear.
- 

**Format complete**

- (5) Press **Enter** to return to the HARD DISK FORMAT menu.

## 3.18 Head Cleaning

### 3.18.1 Function Description

This function cleans the heads in the FDD by executing a series of head load/seek and read operations. A cleaning kit is necessary to perform this function.

### 3.18.2 Operations

1. Select the HEAD CLEANING function by typing **4** from the DIAGNOSTICS MENU and pressing **Enter**. The following message is displayed.

**DIAGNOSTICS - FLOPPY DISK HEAD CLEANING : Vx.xx**

**Mount cleaning disk(s) on drive(s).  
Press any key when ready.**

2. Remove the Diagnostic Disk from the FDD. Then insert the cleaning disk and press **Enter**.

- 
3. When the **Cleaning start** message appears, the FDD head cleaning has begun.
  4. The display automatically returns to the DIAGNOSTICS MENU when the function is completed.
- 

## 3.19 Seek to Landing Zone (HDD)

### 3.19.1 Function Description

When transporting the computer, the HDD heads can hit a surface on the HDD containing data. This can damage the disk surface, thus causing a permanent loss of data. To protect the HDD and its data, the Seek to Landing Zone function moves the HDD heads to safe areas called the “landing zone.”

***NOTE:** The built-in hard disk drive control automatically moves the heads to the landing zones at power down.*

### 3.19.2 Operations

1. Select the SEEK TO LANDING ZONE function by typing **3** and pressing **Enter** from the DIAGNOSTICS MENU. The function is automatically executed and the following message

---

will appear.

---

```
Landing seek complete. (HDD#1)
Press [Enter] key.
```

2. After pressing **Enter**, the DIAGNOSTICS MENU appears.

## 3.20 Log Utilities

### 3.20.1 Function Description

This function logs error information generated while a test is in progress and stores the results in RAM. This function can store data on a floppy disk or output the data to a printer. If the power switch is turned off, the error information will be lost. The error information is displayed in the following order:

1. Error count (CNT)
2. Test name (TS-NAME)
3. Subtest number (TS-NAME)
4. Pass count (PASS)
5. Error status (STS)
6. FDD/HDD or memory address (ADDR)
7. Write data (WD)
8. Read data (RD)
9. HDC status (HSTS)
10. Error status name ([ERROR STATUS NAME])

### 3.20.2 Operations

1. Select the LOG UTILITIES function by typing **5** and pressing **Enter** from the DIAGNOSTICS MENU. Error information will now be logged into RAM or on the floppy disk. The error information is displayed in the following format.

```
      XXXXX ERRORS
CNT TS-NAME PASS  STS  ADDR  WD RD  HSTS [ERROR STATUS NAME ]
001 FDD 02 0000   103 00001  00 00      FDD - WRITE PROTECTED
001 FDD 01 0000   180 00001  00 00      FDD - TIME OUT ERROR
```

Address  
Error status  
Pass count  
Subtest number  
HDC status  
Read data

Test name  
Error count

Write data

Error status name

`[[ 1:Next,2:Prev,3:Exit,4:Clear,5:Print,6:FD Log Read,7:FD Log Write ]]`

2. The error information displayed on the screen can be manipulated with the following number keys.

Number

| <u>Key</u> | <u>Function</u>                           |
|------------|-------------------------------------------|
| 1          | Scrolls the display to the next page.     |
| 2          | Scrolls the display to the previous page. |
| 3          | Returns to the DIAGNOSTICS MENU.          |

---

|   |                                                 |
|---|-------------------------------------------------|
| 4 | Erases all error log information in RAM.        |
| 5 | Outputs the error log information to a printer. |
| 6 | Reads the log information from a floppy disk.   |
| 7 | Writes the log information to a floppy disk.    |

---

- In the case of “error retry OK,” a capital “R” will be placed at the beginning of error status. However, this is not added to the error count.

## 3.21 Running Test

### 3.21.1 Function Description

This function automatically executes the following tests in sequence:

- System test (Subtest number 01)
- Memory test (Subtest number 01, 02, 03, 04, 06, 07)
- Display test (Subtest number 01 to 08)
- FDD test (Subtest number 02)
- Printer test (Subtest number 03)
- ASYNC test (Subtest number 01)
- HDD test (Subtest number 01, 05)
- Real timer test (Subtest number 02)

The system automatically detects the number of floppy disk drives connected to the T6400 for the FDD test.

### 3.21.2 Operations

**CAUTION:** Do not forget to load a work disk in the FDD. If a work disk is not loaded, an error will be generated during the FDD testing.

- Remove the Diagnostic Disk from the floppy disk drive and insert the work disk.
- Select the RUNNING TEST function by typing **6** from the DIAGNOSTICS MENU and pressing **Enter**. The following message will be displayed.

**Printer wrap around test (Y/N) ?**

Selecting **Yes** executes the printer wraparound test. A printer wraparound connector must be connected to the **PRT/FDD** port on the back of the T6400 to properly execute this test.

- Type **Y** or **N** and press **Enter**. The following message will appear.

**Async #1 wrap around test (Y/N) ?**  
**Async #2 wrap around test (Y/N) ?**

---

Selecting **Yes** executes the ASYNC wraparound test. An RS-232-C wraparound connector must be connected to the **SERIAL A** or **SERIAL B** port on the back of the T6400 to properly execute this test.

---

4. Type **Y** or **N** and press **Enter** to start the test.
5. This program is executed continuously. To terminate the program, press **Ctrl + Break**.

## 3.22 Floppy Disk Drive Utilities

### 3.22.1 Function Description

The Floppy Disk Drive Utilities function formats a floppy disk, copies a floppy disk, and displays the dump list for both a floppy disk and the HDD.

#### 1. FORMAT

***CAUTION:** This option is only for testing a floppy disk drive. The option is different than the Toshiba MS-DOS **FORMAT** command.*

This option can format a 5.25 or 3.5 inch floppy disk in the following formats:

- (1) 2D: Double-sided, double-density, 48/67.5 TPI, MFM mode, 512 bytes, 9 sectors/track.
- (2) 2DD: Double-sided, double-density, double-track, 96/135 TPI, MFM mode, 512 bytes, 9 sectors/track.
- (3) 2HD: Double-sided, high-density, double-track, 96/135 TPI, MFM mode, 512 bytes, 18 sectors/track.

#### 2. COPY

This option copies a source floppy disk to a target floppy disk.

#### 3. DUMP

This option displays the contents of the floppy disks and the designated sectors of the hard disk on the display.

### 3.22.2 Operations

1. Select the FLOPPY DISK DRIVE UTILITIES function by typing **7** from the DIAGNOSTICS MENU and pressing **Enter**. The following message is displayed.

[ FDD UTILITIES ]

- 1 : FORMAT
- 2 : COPY
- 3 : DUMP
- 9 : EXIT TO DIAGNOSTICS MENU

PRESS [1] - [9] KEY

2. FORMAT option

- (1) Selecting FORMAT displays the following message.

```
DIAGNOSTICS - FLOPPY DISK FORMAT : Vx.xx
Drive number select (1=A:,2=B:) ?
```

- (2) Select a drive number and press **Enter** to display the following message.

```
Type select (0:2DD-2DD,1:2D1-2D,2:2D-2HD,3:2HD-2HD) ?
```

- (3) Select a media/drive type number and press **Enter**. A message similar to the one below will be displayed.

```
Warning : Disk data will be destroyed.
```

```
Insert work disk into drive x:
Press any key when ready.
```

- (4) Remove the Diagnostics Disk from the FDD, insert the work disk, and press any key.

The following message will be displayed when the FDD format is executed.

```
[ FDD TYPE ] : TRACK  = xxx
[ FDD TYPE ] : HEAD   = x
[ FDD TYPE ] : SECTOR = xx
```

```
Format start
```

```
[[track, head = xxx x]]
```

After the floppy disk is formatted, the following message will appear.

**Format complete**  
**Another format (1:Yes/2:No) ?**

- (5) If you select **Yes**, the display will repeat the message in step (3) above. If you select **No**, the display returns to the DIAGNOSTICS MENU.

3. COPY option

- (1) When COPY is selected, the following message appears.

**FLOPPY DISK FORMAT & COPY : Vx.xx.**  
**Type select (0:2DD-2DD,1:2D-2D,2:2D -2HD,3:2HD-2HD) ?**

- (2) Select a media/drive type number. A message similar to the one below will be displayed.

**Insert source disk into drive x:**  
**Press any key when ready.**

- (3) Remove the Diagnostic Disk from the FDD, insert the source disk, and press any key. The following message will appear, indicating the program has started.

**[ FDD TYPE ] : TRACK = xxx**  
**[ FDD TYPE ] : HEAD = x**  
**[ FDD TYPE ] : SECTOR = xx**

**Copy start**

**[[ track,head = xxx x ]]**

- (4) Remove the source disk from the FDD, insert a formatted work disk and press any key. The **[[ track,head = xxx x ]]** message will appear and start copying to the target disk. When the amount of data is too large to be copied in one operation the message in step (2) is displayed again.

After the floppy disk has been copied, the following message will appear.

**Copy complete**  
**Another copy (1:Yes/2:No) ?**

- (5) To copy another disk, type **1** and the message in step (1) will be displayed again. If you type **2**, the display returns to the DIAGNOSTICS MENU.



#### 4. DUMP option

- (1) When DUMP is selected, the following message appears.

```
DIAGNOSTICS - HARD DISK & FLOPPY DISK DUMP :Vx.xx
Format type select (0:2DD-2DD,1:2D-2D,2:2D -2HD,3:2HD-2HD)?
```

- (2) Select a format type number. Type the number. If **3** is selected, the display will go to the message in step (5) below.

```
0: Displays a dump list for a floppy disk (2DD).
1: Displays a dump list for a floppy disk (2D).
2: Displays a dump list for a floppy disk (2HD).
3: Displays a dump list for a hard disk.
```

- (3) If **0**, **1**, or **2** is selected, the following message will appear.

```
Select FDD number (1:A/2:B) ?
```

- (4) Select an FDD drive number and the following message will appear.

```
Insert source disk into drive x:
Press any key when ready.
```

- (5) Remove the Diagnostic Disk from the FDD and insert a source disk. Press any key and the following message will appear.

```
-- Max. address --
[Track ] = xxxx
[ Head ] = xx
[Sector] = xx
Track number ??
```

- (6) Type the track number and press **Enter**. The following message will appear.

```
Head number ?
```

- (7) Type the head number and press **Enter**. The following message will appear.

```
Sector number ??
```

- (8) Type the sector number and press **Enter**. The specified dump list will be displayed.

- (9) After a dump list appears on the screen, the following message will appear.

```
Press number key (1:up,2:down,3:end) ?
```

```
1: Displays the next sector dump.
```

- 
- 2: Displays a previous sector dump.
  - 3: Displays the following message.
- 

Another dump (1:Yes/2:No) ?

If you type **1**, the display will return to the message shown in step (1) above. If you type **2**, the display will return to the DIAGNOSTICS MENU.

## 3.23 System Configuration

### 3.23.1 Function Description

The System Configuration function contains the following configuration information for the T6400:

- BIOS ROM version
- Base memory size
- Display mode
- Number of floppy disk drives
- Number of ASYNC ports
- Number of hard disk drives
- Number of printer ports
- Co-processor
- Extended memory size

### 3.23.2 Operations

Select the SYSTEM CONFIGURATION function from the DIAGNOSTICS MENU by typing **8** and pressing **Enter**. A system configuration screen similar to the one shown below will be displayed.

```
SYSTEM CONFIGURATION :  
  
* - BIOS ROM VERSION = Vx.xx  
* - 640KB MEMORY  
* - COLOR/GRAPH(80 Column)  
* - 1 FLOPPY DISK DRIVE(S)  
* - 1 ASYNC ADAPTER  
* - 1 HARD DISK DRIVE(S)  
* - 1 PRINTER ADAPTER
```

---

\* - 0 MATH CO-PROCESSOR  
\* - xxxxxKB EXTENDED MEMORY

---

PRESS [ENTER] KEY ?

Press **Enter** to return to the DIAGNOSTICS MENU.

## 3.24 SETUP

### 3.24.1 Function Description

This function displays the current system setup information as listed below.

#### MEMORY

- Total
- Base
- Extended Memory
- Shadow BIOS

#### DISPLAY (*LCD model*)

- Display Adapter
- Display Device
- LCD Display Mode
- LCD Display Colors

#### DISPLAY (*PDP model*)

- Display Adapter
- Display Device
- Plasma Display Mode
- Plasma Gray Scale

#### HARDDISK

- Capacity

#### CPU

- CPU Type
- CPU Clock Speed

#### COM/PRT/FDD

- Serial Port
- Built-in Modem
- Expansion Slot
- External FDD/PRT
- Printer Port Type

#### OTHERS

- Processing Speed
- Cache

Display Auto Off  
Numlock Init. State

## POWER ON PASSWORD

## TIME & DATE

T6400 SETUP

| MEMORY      |          | COM/PRT/FDD       |                    |
|-------------|----------|-------------------|--------------------|
| Total       | = 4096KB | Serial Port       | = COM1 (IRQ4/3F8H) |
| Base        | = 640KB  | Built-in Modem    | = COM2 (IRQ3/2F8H) |
| Extended    | = 3328KB | Expansion Slot    | = IRQ3 Disable     |
| Shadow BIOS | = 128KB  | External FDD/PRT  | = Printer          |
|             |          | Printer Port Type | = Output           |

| DISPLAY             |                                      | OTHERS              |          |
|---------------------|--------------------------------------|---------------------|----------|
| Display Adaptor     | = VGA Compatible                     | Processing Speed    | = High   |
| Display Device      | = Plasma                             | Cache               | = Enable |
| Plasma Display Mode | = Color                              | Display Auto Off    | = 30Min. |
| Plasma Gray Scale   | = Normal:Semi-Bright, Intense:Bright | Numlock init. State | = ON     |

| HARD DISK |         | POWER ON PASSWORD |                |
|-----------|---------|-------------------|----------------|
| Capacity  | = 120MB |                   | Not Registered |

| CPU             |         | TIME & DATE |                            |
|-----------------|---------|-------------|----------------------------|
| CPU Type        | = 486SX |             | 15:05:16, Thu Jan 09, 1992 |
| CPU Clock Speed | = 25MHz |             |                            |

### 3.24.2 Accessing the SETUP

T6400 SETUP

| MEMORY      |          | COM/PRT/FDD       |                    |
|-------------|----------|-------------------|--------------------|
| Total       | = 4096KB | Serial Port       | = COM1 (IRQ4/3F8H) |
| Base        | = 640KB  | Built-in Modem    | = COM2 (IRQ3/2F8H) |
| Extended    | = 3328KB | Expansion Slot    | = IRQ3 Disable     |
| Shadow BIOS | = 128KB  | External FDD/PRT  | = Printer          |
|             |          | Printer Port Type | = Output           |

| DISPLAY            |                  | OTHERS              |          |
|--------------------|------------------|---------------------|----------|
| Display Adaptor    | = VGA Compatible | Processing Speed    | = High   |
| Display Device     | = LCD            | Cache               | = Enable |
| LCD Display Mode   | = Color          | Display Auto Off    | = 30Min. |
| LCD Display Colors | = 180K Colors    | Numlock init. State | = ON     |

| HARD DISK |         | POWER ON PASSWORD |                |
|-----------|---------|-------------------|----------------|
| Capacity  | = 120MB |                   | Not Registered |

| CPU             |         | TIME & DATE |                            |
|-----------------|---------|-------------|----------------------------|
| CPU Type        | = 486SX |             | 15:05:16, Thu Jan 09, 1992 |
| CPU Clock Speed | = 25MHz |             |                            |

Select the **SETUP** function by typing **0** from the **DIAGNOSTICS MENU** and pressing **Enter**. A display similar to one of the following will appear depending on the display type.

#### Gas Plasma Display

#### Color LCD Display

These displays are examples of the setup options as they currently may be stored in memory. The display you see may be different from the above. The available setup options for the display are dependent on the value selected for "Display Adapter."

Press **Esc** if the setup options displayed accurately reflect your hardware configuration and no changes are necessary.

### 3.24.3 Changing SETUP Values

The SETUP values for the T6400 can be changed automatically to their default settings or manually to user-defined settings.

#### Automatic Reset

Follow these steps to set all of the SETUP options to their default settings.

1. Press **Home**. This instructs the program to reset all the options to their default settings.

The program calculates how much base and extended memory your T6400 has based on whether or not you have an expansion memory card installed.

The T6400 SETUP menu displays the new values.

2. Confirm that the new SETUP values are correct. To change any option(s), go to the next section, **Manual Reset**.
3. If the new values are correct, proceed to step 4 in the **Manual Reset** section below.

#### Manual Reset

Follow these steps to change any SETUP option(s) manually:

**NOTE:** *The cursor, shown as a reverse video bar, indicates which option is presently selected for change.*

1. Use the arrow keys or **Enter** to move the cursor between the options. You can also select each option group by pressing the character on the keyboard corresponding to the first character of the heading for each option group. For example, if you press **D**, the cursor moves to the top of the DISPLAY option group.
2. When the option you want to change is highlighted, press the **Spacebar** and/or **Backspace** keys to display the alternate values.
3. When you finish making changes, press **End** to record the new values in the configuration memory.
4. The SETUP menu displays the following message.

**Save Settings and Reboot? (Y/N)**

5. Review your changes. If you need to make more alterations, press **N** and return to step 1 above.

6. If the new values are correct in SETUP and the following message is displayed, proceed to step 7. Otherwise, proceed to step 8.

**Insert Password Disk if necessary.**

The above message is displayed when you enable the Power On Password option.

7. Insert a diskette in drive A. This diskette will become your password service disk that you can use to start up the computer if you forget the password.

**NOTE:** *The contents of the diskette will be erased when the password service disk is created. You can insert either an unformatted or formatted diskette for the password service disk.*

8. Press Y in response to saving the SETUP changes. If you inserted a diskette for the password disk procedure, the SETUP will create the password service disk. When the procedure is completed, the following message is displayed.

**Remove the Password Service Disk and Press any key.**

Remove the diskette and press any key. The diskette should be stored in a safe place.

9. The new SETUP values are now recorded in CMOS memory and the system reboots.

### 3.24.4 SETUP Option Descriptions

This section explains the alternate settings for each SETUP option.

#### MEMORY

This group of options displays the configuration of the memory installed in the T6400. This is only for your information and cannot be changed through the SETUP function.

##### TOTAL

The SETUP function automatically calculates the total amount of memory that is built into the T6400 and displays it. This is only for your information and cannot be changed.

##### BASE

The SETUP function displays the amount of base (conventional) memory, which is 640KB. This is for your information only and cannot be changed.

##### EXTENDED

The SETUP function calculates the amount of extended memory. This is only for your information and cannot be changed.

## SHADOW BIOS

The SETUP function indicates that 128KB of RAM is reserved for the Shadow BIOS ROM. This is only for your information and cannot be changed.

***NOTE:** There is not an option to select expanded memory in the System Configuration Setup. You need to include the Expanded Memory Manager (EMM386.EXE) in the CONFIG.SYS file to emulate expanded memory in extended memory.*

## DISPLAY

The SETUP program displays different options depending on the display type of your T6400 series: Gas Plasma or Color LCD.

### *GAS PLASMA*

#### DISPLAY ADAPTER

Use this option to choose the internal display adapter.

**VGA Compatible** Chooses the internal display adapter for the VGA display. This is the default setting

**Not Used** Internal display adapter is disabled. You can install any external display controller card in the expansion slots. Remaining display setup options are not available.

#### DISPLAY DEVICE

Use this option to select whether the screen will display on the T6400's plasma display and/or on an external CRT via the RGB port on the back of the computer. If a CRT is connected to the T6400, the display mode of the plasma display is set to either color or monochrome, according to the type of the CRT (color or monochrome).

**Plasma** Specifies the dual display mode. The screen appears on both the CRT and plasma display simultaneously. The display mode of the plasma display agrees with the mode of the CRT. In this case, the border section of the CRT is not displayed on the plasma display. This is the default setting.

**CRT** Specifies the CRT mode. The screen appears only on the CRT. Remaining display setup options are not available when

you choose this setting.

#### PLASMA DISPLAY MODE

This option selects whether the plasma display uses monochrome mode or color mode. If there is a CRT attached to the T6400, the display mode of the plasma display is determined by the type of the CRT (either monochrome or color), and the setting for this option has no effect.

**Color** Displays in the color mode. 256 colors of color data are converted to up to 16 levels of gray (orange) for the plasma display. This is the default setting.

**Monochrome** Displays in the monochrome mode with 16 levels of gray (orange) for the plasma display.

#### PLASMA GRAY SCALE

This option specifies the relationship between the brightness levels for characters displayed in normal and intense display modes.

**Normal:Semi-Bright, Intense:Bright** A semi-bright brightness level (gray scale level 11) will be used to display characters.

**Normal:Bright, Intense:Semi-Bright** The maximum brightness level (gray scale level 15) will be used to display characters.

### *COLORLCD*

#### DISPLAY ADAPTER

Use this option to choose the internal display adapter.

**VGA Compatible** Chooses the internal display adapter for the VGA display. This is the default setting

**Not Used** Internal display adapter is disabled. You can install any external display controller card in the expansion slots. Remaining display setup options are not available.

#### DISPLAY DEVICE

Use this option to select whether the screen will display on the T6400's color LCD display and/or on an external CRT via the RGB port on the back of the computer. If a CRT is connected to the T6400, the display mode of the color LCD display is set to either color or monochrome, according to the type of the CRT (color or monochrome).

**LCD** Specifies the dual display mode. The screen appears on both the CRT and color LCD simultaneously. The display mode of the color LCD display agrees with the mode of the CRT. In this case, the border section of the CRT is not displayed on the



**CRT** color LCD display. This is the default setting.  
Specifies the CRT mode. The screen appears only on the CRT. Remaining display setup options are not available when you choose this setting.

#### LCD DISPLAY MODE

This option selects whether the color LCD display uses monochrome mode or color mode. If there is a CRT attached to the T6400, the display mode of the color LCD display is determined by the type of the CRT (either monochrome or color), and the setting for this option has no effect.

**Color** Displays in the color mode. A maximum of 180K colors are displayed. This is the default setting.

**Monochrome** Displays in the monochrome mode with 16 levels of gray for the color LCD display.

#### LCD DISPLAY COLORS

This option selects whether the color LCD display supports 512 colors or 180K colors. This option appears only if you selected Color for LCD Display Mode option.

**180K Colors** Supports 180K colors. This is the default setting.

**512 Colors** Supports 512 colors.

#### HARDDISK

This option displays the size and type of hard disk installed in the T6400.

**Capacity = xxMB** Sets the hard disk to its standard setting. This is the default setting.

**No Drive** Disables the hard disk. The T6400 functions as if a hard disk is not installed.

#### CPU

This group of options displays the CPU type and speed. This information is for your review only and cannot be changed with the SETUP function.

**CPU Type = 486xx** Indicates either the Intel 486SX or 486DX CPU.

**CPU Clock Speed = xxMHz** Indicates the current operating speed set for the CPU.

## COM/PRT/FDD

This group of options allows you to set the serial and parallel ports and the built-in modem. The serial port interrupt level (IRQ) and I/O port base address for each COM level are shown below.

### SERIAL PORT

This option allows you to select either COM1 or COM2 for the serial port.

- |                         |                                                                                                                                                       |
|-------------------------|-------------------------------------------------------------------------------------------------------------------------------------------------------|
| <b>COM1 (IRQ4/3F8H)</b> | Assigns COM1 to the serial port. This is the default setting.                                                                                         |
| <b>COM2 (IRQ3/2F8H)</b> | Assigns COM2 to the serial port.                                                                                                                      |
| <b>Not used</b>         | Disables the serial port. You can now install an optional card into the expansion chassis without any conflict with the COM level of the serial port. |

### BUILT-IN MODEM

This option allows you to select either COM1 or COM2 for the built-in modem port.

- |                         |                                                                                                                                                                       |
|-------------------------|-----------------------------------------------------------------------------------------------------------------------------------------------------------------------|
| <b>COM1 (IRQ4/3F8H)</b> | Assigns COM1 to the built-in modem port.                                                                                                                              |
| <b>COM2 (IRQ3/2F8H)</b> | Assigns COM2 to the built-in modem port. This is the default setting.                                                                                                 |
| <b>Not used</b>         | Disables the built-in modem port. You can now install an optional card into the expansion chassis without any conflict with the COM level of the built-in modem port. |

### EXPANSION SLOT

This option allows you to enable and disable IRQ3 for the expansion slot. When enabled, the SETUP program checks whether COM (IRQ3/2F8H) is selected as a COM level for Serial Port or Built-in Modem option, and selects Not Used if selected.

- |                     |                                                                                                                                                                                                                                                                                                            |
|---------------------|------------------------------------------------------------------------------------------------------------------------------------------------------------------------------------------------------------------------------------------------------------------------------------------------------------|
| <b>IRQ3 Disable</b> | IRQ3 for the expansion slot is disabled.                                                                                                                                                                                                                                                                   |
| <b>IRQ3 Enable</b>  | IRQ3 for the expansion slot is enabled. The SETUP function checks whether COM2 (IRQ3/2F8H) is already assigned as the COM level for the Serial Port or Built-in Modem Port. If COM2 has already been assigned, Not used is automatically assigned to that port and IRQ3 is assigned to the expansion slot. |

### EXTERNAL FDD/PRT

This option sets the assignment of the parallel port (**PRT/FDD**).

- |                |                                                                                                                                         |
|----------------|-----------------------------------------------------------------------------------------------------------------------------------------|
| <b>Printer</b> | Configures the parallel port for output to a parallel printer.<br><del>The internal FDD becomes drive A. This is the default set-</del> |
|----------------|-----------------------------------------------------------------------------------------------------------------------------------------|

ting.

**FDD A** Configures the port for output and input with an external floppy disk drive and assigns the external drive as A. By default the internal FDD becomes drive B.

**FDD B** Configures the port for output and input with an external floppy disk drive and assigns the external drive as B. By default the internal FDD becomes drive A.

#### PRINTER PORT TYPE

When the PRT/FDD port on the rear panel of the T6400 is set for output to the Printer as opposed to the external FDD, this option lets you change the printer port from output only to receive input as well as output. Do not change this setting if you're connecting the T6400 to a printer. You would change this option only if you're connecting the computer to a device that requires a bi-directional parallel signal.

**Output** Activates the uni-directional parallel signal (output only). This is the default setting.

**Bi-Directional** Activates the bi-directional parallel signal (input and output).

#### OTHERS

##### PROCESSING SPEED

Use this option to select the CPU speed. Some optional boards and application software are dependent on the CPU speed. If your optional card or application software doesn't run with High speed, select Normal or Low so that they may run. Some memory cards in the expansion slots may require Normal speed.

**High** The CPU runs with the maximum CPU speed at which the T6400 can operate. This speed may not be fully compatible with the IBM PC/AT bus.

**Normal** The CPU runs with the maximum CPU speed at which the T6400 is fully compatible with the IBM PC/AT bus.

**Low** The CPU runs at half the CPU speed of the High setting.

##### CACHE

This option enables and disables the CPU cache. You may have to select Disable when you run some speed-dependent application software.

**Enable** CPU cache is enabled (high speed)

**Disable** CPU cache is disabled (relatively low speed)

#### DISPLAY AUTO OFF

This option disables or sets the duration of the display automatic power off function.

**30 Min.** Automatically turns off power to the internal display if there is no keyboard activity for 30 minutes.

**Disable** Disables the display automatic power function. This is the default setting.

#### NUMLOCK INIT. STATE

This option is used to determine the state of the Numlock key when the computer is turned on or rebooted.

**ON** Automatically turns on the Numlock key when the computer is turned on or rebooted. This is the default setting.

**OFF** Leaves the Numlock key off when the computer is turned on or rebooted.

#### POWER ON PASSWORD

This option allows you to enable or disable the password required for the T6400 to power on and allow access to the C prompt.

**Registered** Enables the Power On Password function. The computer will require the correct password before allowing the power on sequence to continue.

**Not Registered** Disables the Power On Password function. By disabling the password, the computer erases the previous password from memory.

When servicing a customer's computer that has the Power On Password function enabled, you can use the customer's Password Service Disk or the printer wraparound connector tool. The printer wraparound connector must be connected to the **PRT/FDD** port before you turn the computer on. This will automatically disable the Power On Password function and the SETUP function will save this setting change when you turn the computer off.

***NOTE:** If you use the printer wraparound connector to disable the Power On Password function, make sure you inform the customer of the change when returning the computer.*

### *ENABLING THE POWER ON PASSWORD FUNCTION*

***NOTE:** Once you register a password, you must enter it at the password prompt every time you turn on or restart the computer.*

To enable the Power On Password function, follow these steps.

1. Highlight the **Not Registered** setting.
2. Press the **Spacebar** or **Backspace** key and the following prompt message appears.

**Password=**

3. Enter a password consisting of up to ten characters. The character string you enter is displayed as a string of asterisks. For example, if you enter a four-character password, the display shows:

**Password=\*\*\*\***

4. Press **Enter** and the following message appears allowing you to verify the password.

**Verify Password=**

5. Re-enter the same character string you entered in step 2 and press **Enter**. If the two character strings match, the password is registered and the display changes to:

**Registered**

If they do not match, the following message appears along with a beep indicating you must repeat steps 1 through 4.

**Entry Error!!**

### *DISABLING THE POWER ON PASSWORD FUNCTION*

To disable the Power On Password function, follow these steps.

1. Highlight the **Registered** setting.
2. Press the **Spacebar** or **Backspace** key and the following prompt message appears.

**Password=**

3. Enter the currently registered password. The character string you enter is displayed as a string of asterisks.

**Password=\*\*\*\***

4. Press **Enter**. If the character string you entered matches the registered password, the password option is reset and the display changes to:

**Not Registered.**

If they do not match, the following message appears along with a beep and the display returns to Registered.

## TIME & DATE

The SETUP function displays the current time and date values stored by the calendar clock timer. You can change these values by using the **Spacebar** and **Backspace** keys.

---

# **Chapter 4**

## **Replacement Procedures**

---

This page intentionally left blank



---

# Contents

---

|        |                                                             |      |
|--------|-------------------------------------------------------------|------|
| 4.1    | General .....                                               | 4-5  |
| 4.1.1  | Before You Begin .....                                      | 4-5  |
| 4.1.2  | Disassembly Procedures .....                                | 4-6  |
| 4.1.3  | Installation (Reassembly) Procedures .....                  | 4-6  |
| 4.1.4  | Tools and Equipment .....                                   | 4-7  |
| 4.2    | Keyboard .....                                              | 4-8  |
| 4.2.1  | Removing the Keyboard .....                                 | 4-8  |
| 4.2.2  | Installing the Keyboard Assembly .....                      | 4-11 |
| 4.3    | Central Processor Unit and Oscillator .....                 | 4-12 |
| 4.3.1  | Removing the Central Processor Unit .....                   | 4-12 |
| 4.3.2  | Removing the Oscillator .....                               | 4-13 |
| 4.3.3  | Installing the Central Processing Unit and Oscillator ..... | 4-13 |
| 4.4    | Top Cover .....                                             | 4-15 |
| 4.4.1  | Removing the Top Cover .....                                | 4-15 |
| 4.4.2  | Installing the Top Cover .....                              | 4-18 |
| 4.5    | System Board .....                                          | 4-20 |
| 4.5.1  | Removing the System Board .....                             | 4-20 |
| 4.5.2  | Installing the System Board .....                           | 4-21 |
| 4.6    | 3.5" Floppy Disk Drive .....                                | 4-22 |
| 4.6.1  | Removing the 3.5" Floppy Disk Drive .....                   | 4-22 |
| 4.6.2  | Installing the 3.5" Floppy Disk Drive .....                 | 4-23 |
| 4.7    | 3.5" Hard Disk Drive .....                                  | 4-24 |
| 4.7.1  | Removing the 3.5" Hard Disk Drive .....                     | 4-24 |
| 4.7.2  | Installing the 3.5" Hard Disk Drive .....                   | 4-25 |
| 4.8    | Speaker .....                                               | 4-26 |
| 4.8.1  | Removing the Speaker .....                                  | 4-26 |
| 4.8.2  | Installing the Speaker .....                                | 4-26 |
| 4.9    | DC Fans .....                                               | 4-27 |
| 4.9.1  | Removing the DC Fans .....                                  | 4-27 |
| 4.9.2  | Installing the DC Fans .....                                | 4-27 |
| 4.10   | Power Supply Unit .....                                     | 4-28 |
| 4.10.1 | Removing the Power Supply Unit .....                        | 4-28 |
| 4.10.2 | Installing the Power Supply Unit .....                      | 4-28 |
| 4.11   | LED Board and Display Shut-Off Switch .....                 | 4-29 |
| 4.11.1 | Removing the LED Board and Display Shut-Off Switch .....    | 4-29 |
| 4.11.2 | Installing the LED Board and Display Shut-Off Switch .....  | 4-30 |
| 4.12   | Display Mask .....                                          | 4-31 |
| 4.12.1 | Removing the Display Mask .....                             | 4-31 |
| 4.12.2 | Installing the Display Mask .....                           | 4-32 |
| 4.13   | Gas Plasma Display .....                                    | 4-33 |
| 4.13.1 | Removing the Gas Plasma Display .....                       | 4-33 |
| 4.13.2 | Installing the Gas Plasma Display .....                     | 4-35 |
| 4.14   | Sharp Color LCD .....                                       | 4-36 |
| 4.14.1 | Disassembling the Sharp Color LCD .....                     | 4-36 |
| 4.14.2 | Installing the Sharp Color LCD .....                        | 4-38 |
| 4.15   | DTI Color LCD .....                                         | 4-39 |
| 4.15.1 | Disassembling the DTI Color LCD .....                       | 4-39 |
| 4.15.2 | Installing the DTI Color LCD .....                          | 4-40 |
| 4.16   | Display Cable .....                                         | 4-41 |
| 4.16.1 | Removing the Display Cable .....                            | 4-41 |
| 4.16.2 | Installing the Display Cable .....                          | 4-41 |

## Figures

|             |                                                                     |      |
|-------------|---------------------------------------------------------------------|------|
| Figure 4-1  | Removing the seven system board cover screws .....                  | 4-8  |
| Figure 4-2  | Removing the keyboard cable .....                                   | 4-9  |
| Figure 4-3  | Removing the keyboard base .....                                    | 4-9  |
| Figure 4-4  | Removing the scan controller screws .....                           | 4-10 |
| Figure 4-5  | Disconnecting the keyboard cable and keyboard interface cable ..... | 4-10 |
| Figure 4-6  | Removing the keyboard from the keyboard cover .....                 | 4-11 |
| Figure 4-7  | Releasing the CPU lever .....                                       | 4-12 |
| Figure 4-8  | Removing the CPU .....                                              | 4-12 |
| Figure 4-9  | Removing the oscillator .....                                       | 4-13 |
| Figure 4-10 | Installing the central processor unit .....                         | 4-13 |
| Figure 4-11 | Installing the oscillator .....                                     | 4-14 |
| Figure 4-12 | Removing the built-in modem cover and case .....                    | 4-15 |
| Figure 4-13 | Removing the seven screws .....                                     | 4-16 |
| Figure 4-14 | Removing the rear cover and rear support screws .....               | 4-16 |
| Figure 4-15 | Removing the display hinge screw .....                              | 4-17 |
| Figure 4-16 | Removing the five screws and 3.5" FDD port cover .....              | 4-17 |
| Figure 4-17 | Disconnecting the four cables .....                                 | 4-18 |
| Figure 4-18 | Removing the I/O interface board screws .....                       | 4-20 |
| Figure 4-19 | Disconnecting the FDD, HDD, DC fan cables, and speaker .....        | 4-20 |
| Figure 4-20 | Removing the system board screws .....                              | 4-21 |
| Figure 4-21 | Removing the four FDD screws .....                                  | 4-22 |
| Figure 4-22 | Removing the FDD bracket screws .....                               | 4-22 |
| Figure 4-23 | Removing the HDD .....                                              | 4-24 |
| Figure 4-24 | Removing the HDD bracket .....                                      | 4-24 |
| Figure 4-25 | Removing the speaker .....                                          | 4-26 |
| Figure 4-26 | Removing the DC fans .....                                          | 4-27 |
| Figure 4-27 | Removing the power supply unit .....                                | 4-28 |
| Figure 4-28 | Removing the LED board .....                                        | 4-29 |
| Figure 4-29 | Removing the display shut-off switch .....                          | 4-29 |
| Figure 4-30 | Removing the display mask screws .....                              | 4-31 |
| Figure 4-31 | Removing the display mask .....                                     | 4-32 |
| Figure 4-32 | Removing the brightness control board .....                         | 4-33 |
| Figure 4-33 | Removing the gas plasma display screws .....                        | 4-33 |
| Figure 4-34 | Disconnecting the display cables .....                              | 4-34 |
| Figure 4-35 | Removing the DC-DC converter .....                                  | 4-34 |
| Figure 4-36 | Removing the three back display cover screws .....                  | 4-35 |
| Figure 4-37 | Removing the DC-DC converter board .....                            | 4-36 |
| Figure 4-38 | Removing the FL inverter board screws .....                         | 4-36 |
| Figure 4-39 | Disconnecting the FL inverter cables .....                          | 4-37 |
| Figure 4-40 | Removing the color LCD screws .....                                 | 4-37 |
| Figure 4-41 | Removing the color LCD .....                                        | 4-37 |
| Figure 4-42 | Removing the four back display cover screws .....                   | 4-38 |
| Figure 4-43 | Removing the FL inverter board .....                                | 4-39 |
| Figure 4-44 | Removing the color LCD screws and display cable .....               | 4-39 |
| Figure 4-45 | Removing the four back display cover screws .....                   | 4-40 |
| Figure 4-46 | Removing the display cable .....                                    | 4-41 |

---

## 4.1 General

---

This section explains how to disassemble and reassemble the T6400 to replace the Field Replaceable Units (FRUs). It is not always necessary to remove all the FRUs in order to replace one. The chart below is a guide to which FRUs need to be removed so you can replace the one that is causing the T6400 to operate abnormally. Always start by removing the AC Power Cord, then follow the lines on the chart below to the FRU you are removing.

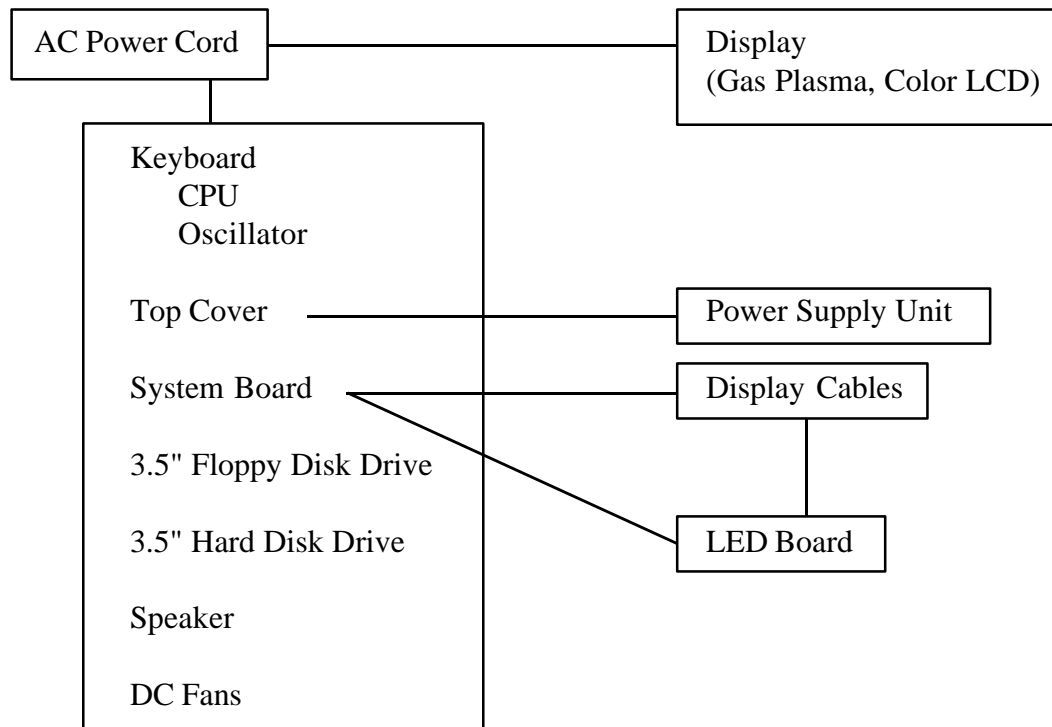

### 4.1.1 Before You Begin

Review the procedures in this section before you begin disassembling the T6400. Familiarize yourself with the steps required to disassemble and reassemble the T6400. Begin each procedure by removing the AC power cord.

1. Do not disassemble the T6400 unless it is operating abnormally.
2. Use only the correct and approved tools.
3. Make sure the working environment is free from the following elements whether you are using or storing the T6400:
  - Dust and contaminants
  - Static electricity
  - Extreme heat, cold, and humidity

4. Make sure the FRU you are replacing is causing the T6400 to operate abnormally by performing the necessary diagnostic tests described in Chapter 3 of this manual.
5. Do not perform any operations that are not necessary.
6. Follow the described procedures for disassembling and installing FRUs in the T6400.
7. After removing parts from the computer, place them in a safe place away from the computer so they will not be damaged and do not interfere with your work.
8. You will remove and replace many screws when you disassemble the T6400. When you remove screws, make sure they are placed in a safe place and identified with the correct parts.
9. When reassembling the T6400, make sure you use the correct screws to secure the various pieces in place. Screw sizes are shown in the corresponding Figures.
10. The T6400 contains many sharp edges and corners. Be careful not to injure yourself.
11. After you have replaced an FRU, make sure the T6400 is functioning properly by performing the appropriate diagnostic test on the FRU you have fixed or replaced.

#### **4.1.2 Disassembly Procedures**

The T6400 has two basic types of cable connectors:

- Pressure Plate Connectors
- Normal Pin Connectors

To disconnect a Pressure Plate Connector, release the tabs on both sides of the plastic connector and slide the cable out of the connector. To connect a cable to a Pressure Plate Connector, make sure the tabs of the Pressure Plate Connector are fully extended and then slide the cable into the connector. Secure the cable in place by pressing down on the tabs so they are flush with the sides of the connector. Gently pull on the cable to make sure the cable is secure. If the cable comes out of the connector, connect it again making sure the tabs of the connector are fully extended when you insert the cable.

#### **4.1.3 Installation (Reassembly) Procedures**

After you have disassembled the T6400 and fixed or replaced the FRU, you will need to reassemble the T6400. Some difficult assemblies are pointed out in the manual, however, most of the time it is sufficient to follow the steps you took to disassemble the T6400 in reverse order. While reassembling the T6400, remember the following general points:

1. Take your time and make sure you follow the instructions closely. Most problems arise when you are in a hurry to reassemble the T6400.

2. Make sure all cables and connectors are securely fastened. These cables all have one side that is silver. Always make sure you connect these cables with the silver side facing up.
3. Before securing replaced parts, make sure that the cables will not be pinched by the screws or parts.
4. Make sure all latches and pressure plate connectors are locked into place.
5. Be sure to use the correct screws to secure the various parts. Screw sizes are listed in the corresponding Figures.
6. Make sure you replace all the screws that were removed during disassembly.
7. After installing an FRU in the T6400 confirm that the FRU and the T6400 are functioning properly.

#### **4.1.4 Tools and Equipment**

The use of ElectroStatic Discharge (ESD) equipment is very important to your safety and the safety of those around you. Proper use of ESD devices will increase the success rate of your repairs and lower the cost of damaged or destroyed parts and FRUs. The following equipment is necessary to disassemble and reassemble the T6400:

- One 2.5mm Phillips-head screwdriver to remove and replace screws.
- One 3mm Phillips-head screwdriver to remove and replace the ground screw.
- One 6mm nut driver for removing the screw extension holders.
- Tweezers to lift out screws that you cannot grasp with your fingers.
- ESD mats for the floor and worktable.
- ESD wrist strap or heel grounder.
- Anti-static carpeting and flooring.
- Air ionizers in highly static-sensitive areas.

---

## 4.2 Keyboard

---

### 4.2.1 Removing the Keyboard

1. Open the **Display** on the T6400.
2. Remove the **Keyboard** as if you were going to use the T6400. Place the **Keyboard** in front of the computer.
3. Remove the seven **M2.5x4 Silver Screws** securing the **System Board Cover** to the **Top Cover** (Figure 4-1).

*Figure 4-1 Removing the seven system board cover screws*

4. Remove the **System Board Cover** from the T6400 and place it aside.

5. Locate where the **Keyboard Cable** connects to the **System Board** in the upper right corner of the T6400 (Figure 4-2). Remove the single **M2.5x8 Ground Screw** securing the **Keyboard Cable**. Then disconnect the **Keyboard Cable** from **PJ909** on the **System Board**.
6. Lift the **Keyboard Cable** out (Figure 4-2).

*Figure 4-2 Removing the keyboard cable*

7. Turn the **Keyboard** over. Remove the eight **M2.5x6 Silver Screws** securing the **Keyboard Base** (Figure 4-3).

*Figure 4-3 Removing the keyboard base*

8. Separate the **Keyboard** from the **Keyboard Base**. Locate the **Scan Controller Board** in the upper left corner of the **Keyboard**, where the **Keyboard Cable** is connected to the **Keyboard** (Figure 4-4).
9. Remove the two **M2.5x6 Screws** securing the **Scan Controller Board** to the **Keyboard** (Figure 4-4).

*Figure 4-4 Removing the scan controller screws*

10. Gently lift the **Scan Controller Board** and rotate it toward the computer (Figure 4-5).
11. Disconnect the **Keyboard Interface Cable** from pressure plate **PJ11** on the **Scan Controller Board**. Disconnect the **Keyboard Cable** from **PJ10** on the **Scan Controller Board** (Figure 4-5).

*Figure 4-5 Disconnecting the keyboard cable and keyboard interface cable*



12. To remove the **Keyboard** from the **Keyboard Cover**, remove the two **M2.5x4 Screws** securing the **Keyboard** to the **Keyboard Cover** (Figure 4-6).

*Figure 4-6 Removing the keyboard from the keyboard cover*

#### **4.2.2 Installing the Keyboard Assembly**

1. Place the **Keyboard** in the **Keyboard Cover** (Figure 4-6). Secure the **Keyboard** in place with the two **M2.5x4 Screws**.
2. Connect the **Keyboard Interface Cable** to **PJ11** on the **Scan Controller Board** (Figure 4-5).
3. Locate the connector on the **Keyboard Cable** with the shorter amount of exposed wires. Connect this end to **PJ10** on the **Scan Controller Board** (Figure 4-5).
4. Place the **Scan Controller Board** in the **Keyboard Assembly** (Figure 4-4). Make sure the **Keyboard Ground Cable** is routed under the screw post closest to the **Keyboard Cable** connection. Secure the **Scan Controller Board** in place with the two **M2.5x4 Screws**.
5. The two ends of the **Keyboard Interface Cable** each has an indentation between the ferrite core and the cable connection. These indentations should be positioned in the cutouts provided in the computer.
6. Place the bottom cover of the **Keyboard Assembly** in place (Figure 4-3). Install the eight **M2.5x6 Silver Screws** to secure the bottom cover to the **Keyboard Assembly**.
7. Connect the **Keyboard Cable** to **PJ909** on the system board. Secure the **M2.5x8 Ground Screw** in place (Figure 4-2).
8. Place the **Keyboard Cable** in its holder (Figure 4-2).
9. Place the **System Board Cover** in place and secure it with the seven **M2.5x4 Silver Screws** (Figure 4-1).
10. Route the **Keyboard Cable** through the reservoir along the back edge and place the **Keyboard** into position on the computer.

---

## 4.3 Central Processor Unit and Oscillator

---

### 4.3.1 Removing the Central Processor Unit

1. Remove the **System Board Cover** as instructed in steps 1-4 of Section 4.2.
2. Locate the **CPU** on the left side of the T6400 (Figure 4-7). To release the **CPU** from its socket, lift the lever on the left side of the CPU socket in the direction of the arrow shown in Figure 4-7. Lift the lever up until you hear a click indicating the lever is fully extended.

*Figure 4-7 Releasing the CPU lever*

**CAUTION:** *If the T6400 has been in operation recently, the CPU's surface may be hot. Allow the CPU to cool to the touch before attempting to remove it.*

3. Grasp the **CPU** and lift it out of the T6400 to expose the CPU socket (Figure 4-8).

*Figure 4-8 Removing the CPU*

### 4.3.2 Removing the Oscillator

**NOTE:** *If you are replacing or upgrading the T6400 CPU with another CPU that has a different CPU operating speed, you also have to change the Oscillator.*

1. Locate the **Oscillator** just behind the **CPU** (Figure 4-9).
2. Grasp the **Oscillator** and pull it straight up until it is free from the computer.

*Figure 4-9 Removing the oscillator*

### 4.3.3 Installing the Central Processing Unit and Oscillator

1. Make sure the lever on the CPU Socket is fully extended (Figure 4-8).
2. Correctly align the **CPU** with the CPU Socket. The small circle on the left back corner of the **CPU** should be positioned with the small yellow circle on the **System Board**. These circles indicate the correct positioning of Pin 1 on the **CPU** (Figure 4-10).

**CAUTION:** *Misalignment of Pin 1 on the CPU will cause the system to fail and may permanently damage the CPU.*

*Figure 4-10 Installing the central processor unit*

3. Press down on the **CPU** to firmly connect it with the **System Board**.
4. Lower the lever on the CPU Socket and latch it under the clip on the side of the socket.
5. To install the **Oscillator**, align the **Oscillator** with the Oscillator Socket. Note that the connector is keyed for proper alignment of Pin 1 on the **Oscillator** (Figure 4-11).

*Figure 4-11 Installing the oscillator*

6. Push the **Oscillator** into its socket until it is securely seated.

---

## 4.4 Top Cover

---

### 4.4.1 Removing the Top Cover

1. Remove the **System Board Cover** as instructed in steps 1-4 of Section 4.2.
2. Remove the three **M2.5x4 Silver Screws** securing the **Built-in Modem Cover** to the **Base Assembly** (Figure 4-12).
3. Remove the two **M2.5x4 Silver Screws** securing the **Built-in Modem Case** to the **Base Assembly**.

*Figure 4-12 Removing the built-in modem cover and case*

4. Remove the six **M2.5x8 Silver** and one **M2.5x4 Silver Screws** (Figure 4-13).

**NOTE:** To remove the **DC Fans**, also remove the two **M2.5x4 Silver Screws** indicated in Figure 4-13. To remove the **Top Cover**, it is not necessary to remove these two screws.

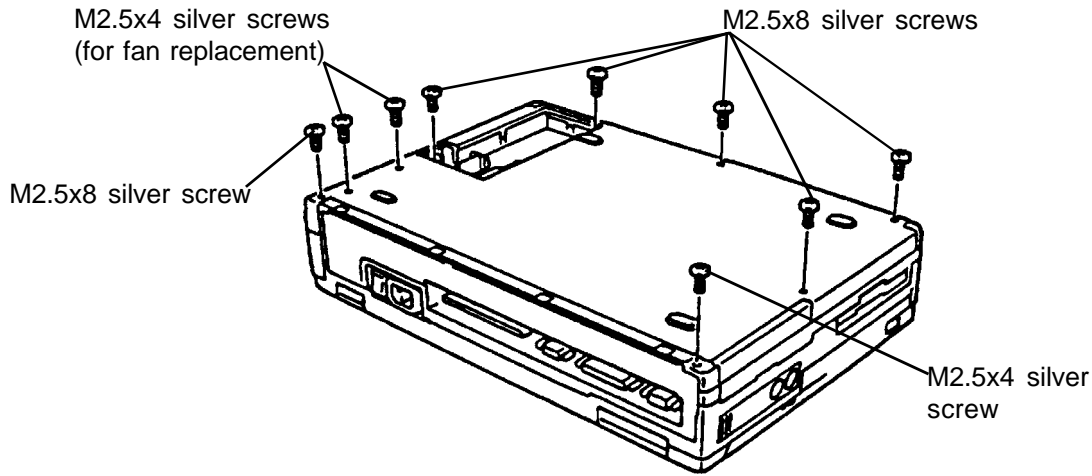

Figure 4-13 Removing the seven screws

5. Turn the T6400 so that its **Rear Cover** is facing you. Remove the four outside **M2.5x4 Silver Screws** and three outside **M2.5x6 Silver Screws** (Figure 4-14). Then remove the **Rear Cover**.
6. Remove the four **M2.5x4 Silver Screws** securing the **Rear Support**. Then remove the **Rear Support**.

**NOTE:** If an expansion card is installed in the expansion slot, remove the one M2.5x4 screw securing the expansion card and then remove the card.

**NOTE:** If your T6400 has a Matsushita Power Supply Unit, the Rear Support is secured by four screws. If your T6400 has a Toshiba Power Supply Unit, the Rear Support is secured by three screws (Figure 4-14).

Figure 4-14 Removing the rear cover and rear support screws

7. Turn the T6400 right side up and open the **Display**. Remove the **Right Display Hinge Cover**. Remove the single **M3x8 Screw** (Figure 4-15).

*Figure 4-15 Removing the display hinge screw*

8. Remove the five **M2.5x8 Screws**. Then remove the **External 3.5" FDD Port Cover** and slide the **Handle** out until it is fully extended (Figure 4-16).

*Figure 4-16 Removing the five screws and 3.5" FDD port cover*

9. Disconnect the **LED Cable** from pressure plate **PJ408**, the **Display Cable** from **PJ404**, and the two **Power Supply Cables** from **PJ901** and **PJ902** on the **System Board** (Figure 4-17).

*Figure 4-17 Disconnecting the four cables*

10. Gently separate the **Top Cover** from the **Base Assembly** and place the **Top Cover** aside. Close the **Display**.

#### **4.4.2 Installing the Top Cover**

1. Connect the two **Power Supply Cables** to **PJ901** and **PJ902**, the **Display Cable** to **PJ404**, and the **LED Cable** to **PJ408** on the **System Board** (Figure 4-17).
2. Align the **Top Cover** with the **Base Assembly**. Make sure the **DC Fan Cables** and **Speaker Cable** are not pinched between the **Top Cover** and the **Base Assembly**. Install the five **M2.5x8** Screws and the **External 3.5" FDD Port Cover** (Figure 4-16). Then retract the **Handle**.
3. Install the single **M3x8 Screw** under the **Right Display Hinge Cover** and snap the **Right Display Hinge Cover** into place (Figure 4-15). Close the **Display**.
4. Turn the T6400 over and install the **Rear Support**. Secure the **Rear Support** in place with the three or four **M2.5x4 Silver Screws**, depending on the **Power Supply Unit** (Figure 4-14).
5. Place the **Rear Cover** over the **Rear Support**. Make sure the plastic tabs snap into place. Then secure the **Rear Cover** in place with the four **M2.5x4 Silver Screws** and three **M2.5x6 Silver Screws** (Figure 4-14).
6. Secure the **Top Cover** in place with the six **M2.5x8 Silver** and one **M2.5x4 Silver Screws** (Figure 4-13). If you disassembled the **DC Fans**, also replace the two **M2.5x4 Silver Screws**.



7. If necessary, install and secure the **Built-in Modem**. Then install the **Built-in Modem Case** and secure it in place with the two **M2.5x4 Silver Screws** (Figure 4-12).
8. Install the **Built-in Modem Cover** and secure it in place with the three **M2.5x4 Silver Screws** (Figure 4-12).

---

## 4.5 System Board

---

### 4.5.1 Removing the System Board

1. Remove the **Top Cover** as instructed in Section 4.4.
2. Remove the two **M3x6 Screws** securing the **I/O Interface Board** in place (Figure 4-18).
3. Gently lift the **I/O Interface Board** straight up to disconnect it from **PJ910** on the **System Board** (Figure 4-18).

*Figure 4-18 Removing the I/O interface board screws*

4. Disconnect the **FDD Cable** from pressure plate **PJ5**, the **HDD Cable** from **PJ7**, the **HDD Power Cable** from **PJ6**, the **DC Fan Cables** from **PJ906** and **PJ907**, and the **Speaker Cable** from **PJ407** on the **System Board** (Figure 4-19).

*Figure 4-19 Disconnecting the FDD, HDD, DC fan cables, and speaker*

5. Remove the two **M2.5x4 Screws** and the two **6mm Screw Extension Holders** securing the **System Board** to the **Base Assembly** (Figure 4-20).

*Figure 4-20 Removing the system board screws*

6. Gently lift the **System Board** out of the T6400.

#### **4.5.2 Installing the System Board**

1. Place the **System Board** in the T6400, making sure the Built-in Modem connector port fits properly into the cutout on the **Base Assembly**. Make sure the **HDD Cable**, **FDD Cable**, **Speaker Cable**, and **DC Fan Cables** are not beneath the **System Board**.
2. Secure the **System Board** in place with the two **M2.5x4 Screws** and the two **6mm Screw Extension Holders** (Figure 4-20).

***NOTE:** The longer Screw Extension Holder goes in the back right corner of the **System Board**.*

3. Connect the **FDD Cable** to **PJ5**, the **HDD Cable** to **PJ7**, the **HDD Power Cable** to **PJ6**, the **DC Fan Cables** to **PJ906** and **PJ907**, and the **Speaker Cable** to **PJ407** on the **System Board** (Figure 4-19).
4. Place the **I/O Interface Board** in the T6400. Gently press down on the **I/O Interface Board** to firmly connect it to **PJ910**. Then secure the board in place with the two **M3x6 Screws** (Figure 4-18).

---

## 4.6 3.5" Floppy Disk Drive

---

### 4.6.1 Removing the 3.5" Floppy Disk Drive

1. Remove the **System Board** as instructed in Section 4.5.
2. Remove the four **M2.5x4 Screws** securing the **FDD** in place. Then lift the **FDD** and its bracket out of the T6400 (Figure 4-21).

*Figure 4-21 Removing the four FDD screws*

3. To remove the **FDD Bracket**, remove the three **M2.5x4 Screws** securing the **FDD** to the **FDD Bracket** (Figure 4-22).

*Figure 4-22 Removing the FDD bracket screws*

#### 4.6.2 Installing the 3.5" Floppy Disk Drive

1. Secure the **FDD Bracket** to the **FDD** with the three **M2.5x4 Screws** (Figure 4-22).
2. Position the **FDD Mask** (CD Attachment) on the **Base Assembly** with the tab facing up and the finished edge of the mask facing outward.
3. Place the **FDD** in the T6400. Make sure the front of the **FDD** is properly aligned with the **FDD Mask** (CD Attachment) on the **Base Assembly**. Secure the **FDD** and the **FDD Bracket** with the four **M2.5x4 Screws** (Figure 4-21).

---

## 4.7 3.5" Hard Disk Drive

---

### 4.7.1 Removing the 3.5" Hard Disk Drive

1. Remove the **System Board** as instructed in Section 4.5.
2. Remove the four **M2.5x4 Screws** securing the **HDD** and the **HDD Bracket** in place. Then lift the **HDD** and its bracket out of the T6400 (Figure 4-23).

*Figure 4-23 Removing the HDD*

3. To remove the **HDD Bracket**, remove the four **Special Screws** securing the **HDD** to the **HDD Bracket**. Then disconnect the **HDD Cable** and **HDD Power Cable** (Figure 4-24) from the HDD.

*Figure 4-24 Removing the HDD bracket*

## 4.7.2 Installing the 3.5" Hard Disk Drive

1. Connect the **HDD Cable** and **HDD Power Cable** to the **HDD** (Figure 4-24). Hold the **HDD** with the connector facing to your right. The silver insert on the connector edge of the **HDD Cable** is the end inserted into the **HDD**.
2. Secure the **HDD Bracket** to the **HDD** with the four **Special Screws** (Figure 4-24).
3. Place the **HDD** in the T6400. Two alignment tabs are located on either side of the **HDD Bracket**. Make sure the HDD cable connector is facing the front of the T6400. Secure the **HDD** and **HDD Bracket** with the four **M2.5x4 Screws** (Figure 4-23).

---

## 4.8 Speaker

---

### 4.8.1 Removing the Speaker

1. Remove the **System Board** as instructed in Section 4.5.
2. Remove the two **M2x4 Screws** securing the **Speaker** to the T6400. Then remove the **Speaker** from the T6400 (Figure 4-25).

*Figure 4-25 Removing the speaker*

### 4.8.2 Installing the Speaker

1. Place the **Speaker** in the T6400. The manufacturer's label should face down and the speaker cable should come out to the left. Secure the **Speaker** in place with the two **M2x4 Screws** (Figure 4-25).



---

## 4.9 DC Fans

---

### 4.9.1 Removing the DC Fans

1. Remove the **System Board** as instructed in Section 4.5.
2. Lift the **DC Fans** out of the **Base Assembly** (Figure 4-26).
3. To remove the **DC Fans** from the **Assembly Bracket**, remove the four **Special Screws** securing the **DC Fans** (Figure 4-26).

*Figure 4-26 Removing the DC fans*

### 4.9.2 Installing the DC Fans

1. Install the **DC Fans** on the **Assembly Bracket**. Position the fans so that the manufacturer's labels are upside down and face the vents on the **Base Assembly**.
2. Secure the **DC Fans** in place with the four **Special Screws** (Figure 4-26).
3. Place the **DC Fan** and the **Assembly Bracket** in the T6400.

---

## 4.10 Power Supply Unit

---

### 4.10.1 Removing the Power Supply Unit

1. Remove the **Top Cover** as instructed in Section 4.4.
2. Turn the **Top Cover** over so its bottom side is facing up. Locate the **Power Supply Unit** (Figure 4-27).
3. Remove the five **M3x6 Screws** securing the **Power Supply Unit** (Figure 4-27). Then lift the **Power Supply Unit** out of the computer.

*Figure 4-27 Removing the power supply unit*

4. You can now lift out the **Display Cable Cover**.

### 4.10.2 Installing the Power Supply Unit

1. Position the ferrite core on the **Display Cable** within the reservoir and beneath the clip on the **Top Cover**.
2. Place the **Display Cable Cover** over the ferrite core on the **Display Cable**, making sure to align the cover with the two guide pins.

**NOTE:** Do not install any screws at this point.

3. Place the **Power Supply Unit** in the T6400 (Figure 4-27).
4. Secure the **Power Supply Unit** in place with the five **M3x6 Screws** (Figure 4-27).

---

## 4.11 LED Board and Display Shut-Off Switch

---

### 4.11.1 Removing the LED Board and Display Shut-Off Switch

1. Remove the **Power Supply Unit** as instructed in Section 4.10.
2. Remove the two **M2.5x4 Screws** securing the **LED Board** to the T6400 (Figure 4-28).
3. Rotate the **LED Board** as shown in Figure 4-28 and disconnect the **Display Shut-Off Switch Cable** from **PJ802** on the **LED Board**. The **LED Board** can now be removed from the T6400.

*Figure 4-28 Removing the LED board*

4. To remove the **Display Shut-Off Switch**, remove the single **M2x8 Screw** securing the **Display Shut-Off Switch** to the **Base Assembly** (Figure 4-29).

*Figure 4-29 Removing the display shut-off switch*

### 4.11.2 Installing the LED Board and Display Shut-Off Switch

1. Install the **Display Shut-Off Switch** and secure it in place with the single **M2x8 Screw** (Figure 4-29).
2. Connect the **Display Shut-Off Switch Cable** to **PJ802** on the **LED Board** and rotate the board into the computer.
3. Align the **LED Board** with the two guide pins and secure the board in place with the two **M2.5x4 Screws** (Figure 4-28).

---

## 4.12 Display Mask

---

### 4.12.1 Removing the Display Mask

1. Open the **Display** (Figure 4-30).
2. Remove the **Rubber Cushions** from the top of the **Display** and the **Display Hinge Covers** from the bottom of the **Display**.
3. Remove the two **M2.5x8 Silver Bottom Screws** and the two **M2.5x4 Silver Top Screws** securing the **Display Mask**.

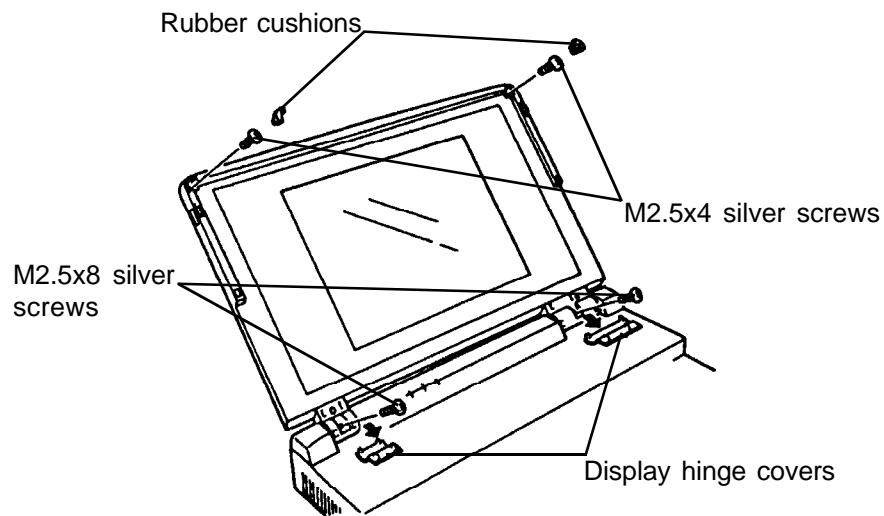

*Figure 4-30 Removing the display mask screws*

4. Separate the **Display Mask** from the **Back Display Cover**. Start with step 1 as shown in Figure 4-31 and proceed with steps 2, 3 and 4. After all the latches on the **Display Mask** are released, remove the **Display Mask** from the T6400.

*Figure 4-31 Removing the display mask*

#### **4.12.2 Installing the Display Mask**

1. Install the **Display Mask** (Figure 4-31).
2. Secure the **Display Mask** in place with the four **M2.5x8 Screws** and install the **Rubber Cushions** and **Display Hinge Covers** (Figure 4-30).

---

## 4.13 Gas Plasma Display

---

### 4.13.1 Removing the Gas Plasma Display

1. Remove the **Display Mask** as described in Section 4.12.
2. Remove the **M2.5x4 Screw** securing the **Brightness Control Board** and disconnect the **Brightness Control Cable** from **PJ803** on the **Brightness Control Board** (Figure 4-32).

*Figure 4-32 Removing the brightness control board*

3. Remove the six **M2.5x4 Screws** securing the **Gas Plasma Display** and the one **M2.5x4 Screw** securing the **DC-DC Converter** (Figure 4-33).

*Figure 4-33 Removing the gas plasma display screws*

4. Gently lift the **Gas Plasma Display** out of the T6400 and lay it on the **Top Cover** of the computer. Disconnect the **Display Cables** from **J1A**, **J1B**, and **J3**. Then disconnect the **DC-DC Converter Cable** from **PJ803** (Figure 4-34).

*Figure 4-34 Disconnecting the display cables*

5. Disconnect the **DC-DC Converter Cable** on the **Gas Plasma Display**. Slide the **DC-DC Converter Cable** out of the clip on the back of the **Gas Plasma Display**. Remove the two **Screws** securing the **DC-DC Converter** to the **Back Display Cover** (Figure 4-35).

*Figure 4-35 Removing the DC-DC converter*



6. To remove the **Back Display Cover**, remove the three **M2.5x4 Screws** securing the **Back Display Cover** to the **Display Hinges** (Figure 4-36).

*Figure 4-36 Removing the three back display cover screws*

#### **4.13.2 Installing the Gas Plasma Display**

1. If necessary, install the **Back Display Cover** and secure it in place with the three **M2.5x4 Screws** (Figure 4-36).
2. Connect the **DC-DC Converter Cable** to the **Gas Plasma Display** (Figure 4-35). Secure the **DC-DC Converter** to the **Back Display Cover** with the two **Screws**. Make sure you connect the **Ground Cable** with the bottom screw.
3. Connect the **Gas Plasma Display Cables** and the **Brightness Control Cable** to the **Gas Plasma Display** (Figure 4-34).
4. Secure the **Gas Plasma Display** and the **Ground Cable** to the **Back Display Cover** with the seven **M2.5x4 Screws** (Figure 4-33).
5. Install the **Brightness Control Board** with the single **M2.5x4 Screw** (Figure 4-32).

---

## 4.14 Sharp Color LCD

---

### 4.14.1 Disassembling the Sharp Color LCD

1. Remove the **Display Mask** as described in Section 4.12.
2. Remove the two **M2.5x4 Screws** securing the **DC-DC Converter Board** (Figure 4-37). Disconnect the cables from the top and the bottom of the **DC-DC Converter Board**.

*Figure 4-37 Removing the DC-DC converter board*

3. Remove the three **M2.5x4 Screws** securing the **FL Inverter Board** (Figure 4-38).

*Figure 4-38 Removing the FL inverter board screws*

4. Disconnect the three cables on the **FL Inverter Board** (Figure 4-39). Remove the **FL Inverter Board** from the T6400.

*Figure 4-39 Disconnecting the FL inverter cables*

5. Remove the four **M2.5x4 Screws** securing the **Color LCD** to the **Back Display Cover** (Figure 4-40).

*Figure 4-40 Removing the color LCD screws*

6. Lay the **Color LCD** on the **Top Cover** and disconnect the **Display Cable** (Figure 4-41).

*Figure 4-41 Removing the color LCD*

7. To remove the **Back Display Cover**, remove the four **M2.5x4 Screws** securing the **Back Display Cover** to the **Display Hinges** (Figure 4-42).

*Figure 4-42 Removing the four back display cover screws*

#### **4.14.2 Installing the Sharp Color LCD**

1. If necessary, install the **Back Display Cover** and secure it in place with the four **M2.5x4 Screws** (Figure 4-42).
2. Connect the **Display Cable** to the **Color LCD** (Figure 4-41).
3. Place the **Color LCD** in the **Back Display Cover** and secure it with the four **M2.5x4 Screws** (Figure 4-40).
4. Place the **FL Inverter Board** in the **Color LCD** and connect the **FL Inverter Cables** (Figure 4-39).
5. Secure the **FL Inverter Board** in place with the three **M2.5x4 Screws** (Figure 4-38).
6. Connect the two cables to the **DC-DC Converter** and secure the converter in place with the two **M2.5x4 Screws** (Figure 4-37).

---

## 4.15 DTI Color LCD

---

### 4.15.1 Disassembling the DTI Color LCD

1. Remove the **Display Mask** as described in Section 4.12.
2. Remove the three **M2.5x4 Screws** securing the **FL Inverter Board** (Figure 4-43). Disconnect the five cables from the **FL Inverter Board**.

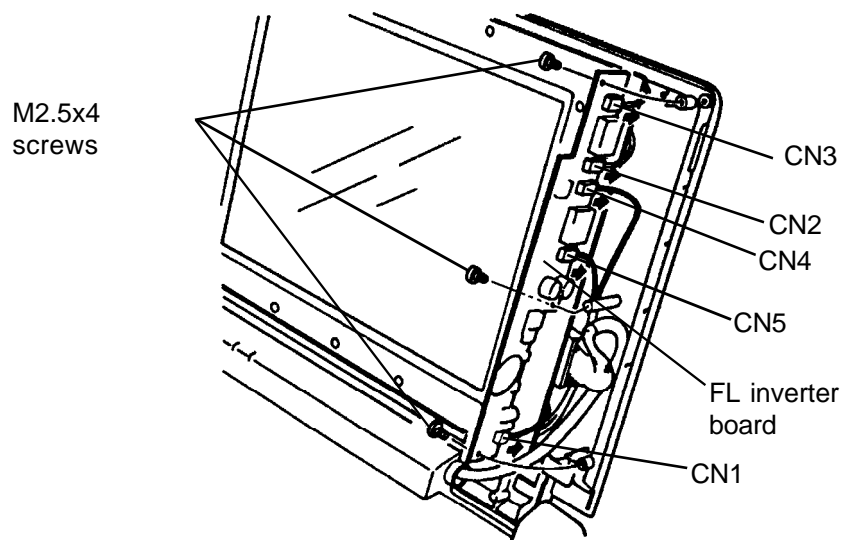

*Figure 4-43 Removing the FL inverter board*

3. Remove the four **M2.5x4 Screws** securing the **Color LCD** to the **Back Display Cover** and disconnect the **Display Cable** (Figure 4-44).

*Figure 4-44 Removing the color LCD screws and display cable*

4. To remove the **Back Display Cover**, remove the four **M2.5x4 Screws** securing the **Back Display Cover** to the **Display Hinges** (Figure 4-45).

*Figure 4-45 Removing the four back display cover screws*

#### **4.15.2 Installing the DTI Color LCD**

1. If necessary, install the **Back Display Cover** and secure it in place with the four **M2.5x4 Screws** (Figure 4-45).
2. Connect the **Display Cable** to the **Color LCD** (Figure 4-44).
3. Place the **Color LCD** in the **Back Display Cover** and secure it with the four **M2.5x4 Screws** (Figure 4-44).
4. Place the **FL Inverter Board** in the **Color LCD** and connect the **FL Inverter Cables** (Figure 4-43).

**NOTE:** *The two white cables at the top of the **Display** go into the two connectors at the top of the **FL Inverter Board**. Make sure to match the colors on the connectors.*

5. Secure the **FL Inverter Board** in place with the two **M2.5x4 Screws** (Figure 4-43).

---

## 4.16 Display Cable

---

### 4.16.1 Removing the Display Cable

1. Remove the **Power Supply Unit**, **Display Mask**, and **Display** as instructed in Sections 4.10; 4.12; and 4.12, 4.13, or 4.14 (depending on the display type).
2. Turn the **Top Cover** upside down. Release the **Display Cable** from its clip. Remove the **M2.5x4 Silver Screw** securing the **Display Cable Cover** (Figure 4-46).

*Figure 4-46 Removing the display cable*

3. Slightly close the **Display** and then slide the **Display Cable** out of the **Top Cover**.

### 4.16.2 Installing the Display Cable

1. Slide the **Display Cable** through the **Top Cover**.
2. Install the **Display Cable Cover** and secure it with the single **M2.5x4 Silver Screw** (Figure 4-46).
3. Secure the **Display Cable** under its clip.

This page intentionally left blank



---

# Appendices

---

This page intentionally left blank

---

# Contents

---

|            |                                                |        |
|------------|------------------------------------------------|--------|
| Appendix A | Board Layouts                                  |        |
| A.1        | System Board (FVCSYx) (ICs) .....              | App-5  |
| A.2        | System Board (FVCSYx) (Connectors) .....       | App-7  |
| A.3        | System Board (FVCSYx) (Oscillators) .....      | App-10 |
| A.4        | LED Board (FVCLEx) .....                       | App-12 |
| A.5        | I/O Interface Board (FVCFDx) .....             | App-12 |
| A.6        | Keyboard Scan Controller Board (FVCKBx).....   | App-12 |
| Appendix B | Pin Assignments for System Board               |        |
| B.1        | PJ1 Memory Slot-A Connector (88-Pin) .....     | App-13 |
| B.2        | PJ2 Memory Slot-B Connector (88-Pin) .....     | App-14 |
| B.3        | PJ3 Modem Connector (30-Pin).....              | App-15 |
| B.4        | PJ4 EXT FDD/PRT Connector (25-Pin) .....       | App-15 |
| B.5        | PJ5 INT FDD Connector (26-Pin) .....           | App-16 |
| B.6        | PJ6 HDD Power Connector (3-Pin) .....          | App-16 |
| B.7        | PJ904 CD-ROM/HDD Power Connector (4-Pin) ..... | App-16 |
| B.8        | PJ7 HDD I/F Connector (40-Pin) .....           | App-17 |
| B.9        | PJ8 RS-232-C Connector (9-Pin) .....           | App-17 |
| B.10       | PJ404 Display Connector (34-Pin) .....         | App-18 |
| B.11       | PJ405 CRT I/O Connector (15-Pin) .....         | App-18 |
| B.12       | PJ406 Expansion Connector (150-Pin).....       | App-19 |
| B.13       | PJ407 Speaker I/F Connector (2-Pin) .....      | App-20 |
| B.14       | PJ408 LED I/F Connector (8-Pin) .....          | App-20 |
| B.15       | PJ411 Feature Connector (26-Pin).....          | App-21 |
| B.16       | PJ412 DVI Support Connector (34-Pin) .....     | App-21 |
| B.17       | PJ413 ISA Slot Connector (104-Pin) .....       | App-22 |
| B.18       | PJ901 PS I/F Connector (6-Pin) .....           | App-23 |
| B.19       | PJ902 PS I/F Connector (4-Pin) .....           | App-23 |
| B.20       | PJ906 Fan I/F Connector (2-Pin) .....          | App-23 |
| B.21       | PJ907 Fan I/F Connector (2-Pin) .....          | App-23 |
| B.22       | PJ909 Int. KB Connector (4-Pin) .....          | App-23 |
| B.23       | PJ910 I/O Board I/F Connector (40-Pin) .....   | App-24 |
| Appendix C | ASCII Character Codes.....                     | App-25 |
| Appendix D | Keyboard Scan/Character Codes.....             | App-26 |
| Appendix E | Keyboard Layouts                               |        |
| E.1        | USA Keyboard .....                             | App-30 |
| E.2        | UK Keyboard .....                              | App-30 |
| E.3        | German Keyboard .....                          | App-31 |
| E.4        | French Keyboard.....                           | App-31 |
| E.5        | Spanish and Latin American Keyboard .....      | App-32 |
| E.6        | Italian Keyboard .....                         | App-32 |
| E.7        | Scandinavian (DK, NO, SW) Keyboard .....       | App-33 |
| E.8        | Swiss (French/German) Keyboard .....           | App-33 |
| Appendix F | Wiring Diagrams                                |        |
| F.1        | Printer Wraparound Connector.....              | App-34 |
| F.2        | RS-232-C Wraparound Connector.....             | App-34 |
| F.3        | RS-232-C Direct Cable (9-Pin to 9-Pin).....    | App-34 |
| F.4        | RS-232-C Direct Cable (9-Pin to 25-Pin) .....  | App-35 |

## Tables

|            |                                                         |        |
|------------|---------------------------------------------------------|--------|
| Table A-1  | ICs on the system board FVCSYx .....                    | App-6  |
| Table A-2  | Connectors on the system board FVCSYx .....             | App-9  |
| Table A-3  | Oscillators on the system board FVCSYx .....            | App-11 |
| Table B-1  | Memory slot-A connector pin assignment (88-pin) .....   | App-13 |
| Table B-2  | Memory slot-B connector pin assignment (88-pin) .....   | App-14 |
| Table B-3  | Modem connector pin assignment (30-pin) .....           | App-15 |
| Table B-4  | EXT FDD/PRT connector pin assignment (25-pin) .....     | App-15 |
| Table B-5  | INT FDD connector pin assignment (26-pin) .....         | App-16 |
| Table B-6  | HDD power connector pin assignment (3-pin) .....        | App-16 |
| Table B-7  | CD-ROM/HDD power connector pin assignment (4-pin) ..... | App-16 |
| Table B-8  | HDD I/F connector pin assignment (40-pin) .....         | App-17 |
| Table B-9  | RS-232-C connector pin assignment (9-pin) .....         | App-17 |
| Table B-10 | Display connector pin assignment (34-pin) .....         | App-18 |
| Table B-11 | CRT I/O connector pin assignment (15-pin) .....         | App-18 |
| Table B-12 | Expansion connector pin assignment (150-pin) .....      | App-19 |
| Table B-13 | Speaker I/F connector pin assignment (2-pin) .....      | App-20 |
| Table B-14 | LED I/F connector pin assignment (8-pin) .....          | App-20 |
| Table B-15 | Feature connector pin assignment (26-pin) .....         | App-21 |
| Table B-16 | DVI support connector pin assignment (34-pin) .....     | App-21 |
| Table B-17 | ISA slot connector pin assignment (104-pin) .....       | App-22 |
| Table B-18 | PS I/F connector pin assignment (6-pin) .....           | App-23 |
| Table B-19 | PS I/F connector pin assignment (4-pin) .....           | App-23 |
| Table B-20 | Fan I/F connector pin assignment (2-pin) .....          | App-23 |
| Table B-21 | Fan I/F connector pin assignment (2-pin) .....          | App-23 |
| Table B-22 | Int KB connector pin assignment (4-pin) .....           | App-23 |
| Table B-23 | I/O board I/F connector pin assignment (40-pin) .....   | App-24 |
| Table C-1  | ASCII character codes .....                             | App-25 |
| Table D-1  | KB code to ASCII code conversion table .....            | App-26 |

## Figures

|            |                                                 |        |
|------------|-------------------------------------------------|--------|
| Figure A-1 | System board FVCSYx (ICs) (front) .....         | App-5  |
| Figure A-3 | System board FVCSYx (connectors) (front) .....  | App-7  |
| Figure A-4 | System board FVCSYx (connectors) (back) .....   | App-8  |
| Figure A-5 | System board FVCSYx (oscillators) (front) ..... | App-10 |
| Figure A-7 | LED board .....                                 | App-12 |
| Figure A-8 | I/O interface board .....                       | App-12 |
| Figure A-9 | Keyboard scan controller board .....            | App-12 |
| Figure E-1 | USA keyboard .....                              | App-30 |
| Figure E-2 | UK keyboard .....                               | App-30 |
| Figure E-3 | German keyboard .....                           | App-31 |
| Figure E-4 | French keyboard .....                           | App-31 |
| Figure E-5 | Spanish and Latin American keyboard .....       | App-32 |
| Figure E-6 | Italian keyboard .....                          | App-32 |
| Figure E-7 | Scandinavian (DK, NO, SW) keyboard .....        | App-33 |
| Figure E-8 | Swiss (French/German) keyboard .....            | App-33 |
| Figure F-1 | Printer wraparound connector .....              | App-34 |
| Figure F-2 | RS-232-C wraparound connector .....             | App-34 |
| Figure F-3 | RS-232-C direct cable (9-pin to 9-pin) .....    | App-34 |
| Figure F-4 | RS-232-C direct cable (9-pin to 25-pin) .....   | App-35 |

# Appendix A Board Layouts

## A.1 System Board (FVCSYx) (ICs)

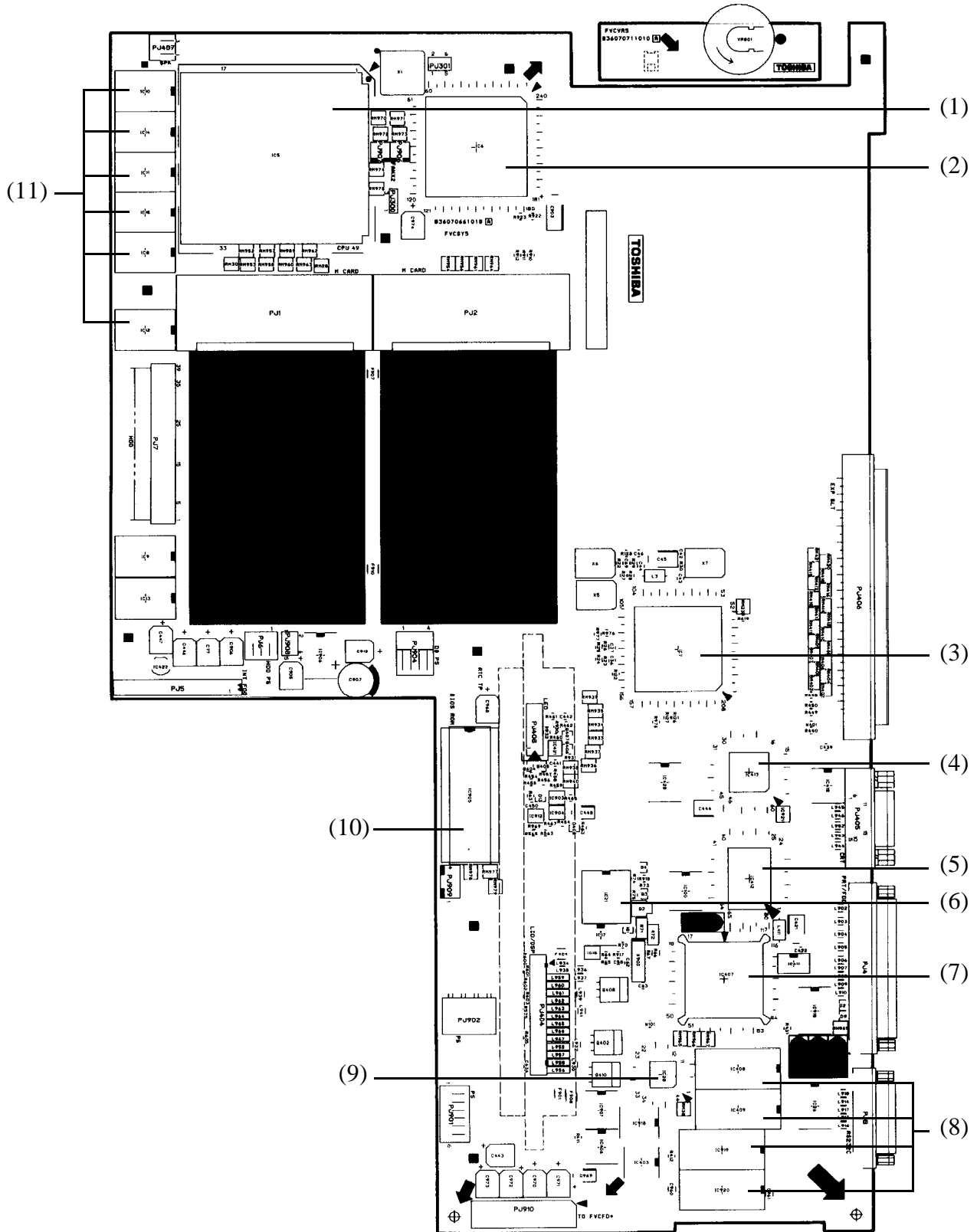

Figure A-1 System board FVCSYx (ICs) (front)

*Table A-1 ICs on the system board FVCSYx*

| <b>Callout</b> | <b>Number</b>                       | <b>Name</b>                                   |
|----------------|-------------------------------------|-----------------------------------------------|
| (1)            | IC5                                 | Central processing unit (CPU) 80486SX/80486DX |
| (2)            | IC6                                 | System controller gate array                  |
| (3)            | IC7                                 | Super integration (SI) T9901                  |
| (4)            | IC413                               | Color gray scale controller (CGSC)            |
| (5)            | IC412                               | Digital analog connector (DAC)                |
| (6)            | IC21                                | Real time clock (RTC)                         |
| (7)            | IC407                               | PVGA1F                                        |
| (8)            | IC408, IC409<br>IC919, IC920        | Video RAM                                     |
| (9)            | IC28                                | Keyboard controller (KBC)                     |
| (10)           | IC905                               | BIOS ROM                                      |
| (11)           | IC8, IC10, IC11<br>IC12, IC14, IC15 | System Memory                                 |

## A.2 System Board (FVCSYx) (Connectors)

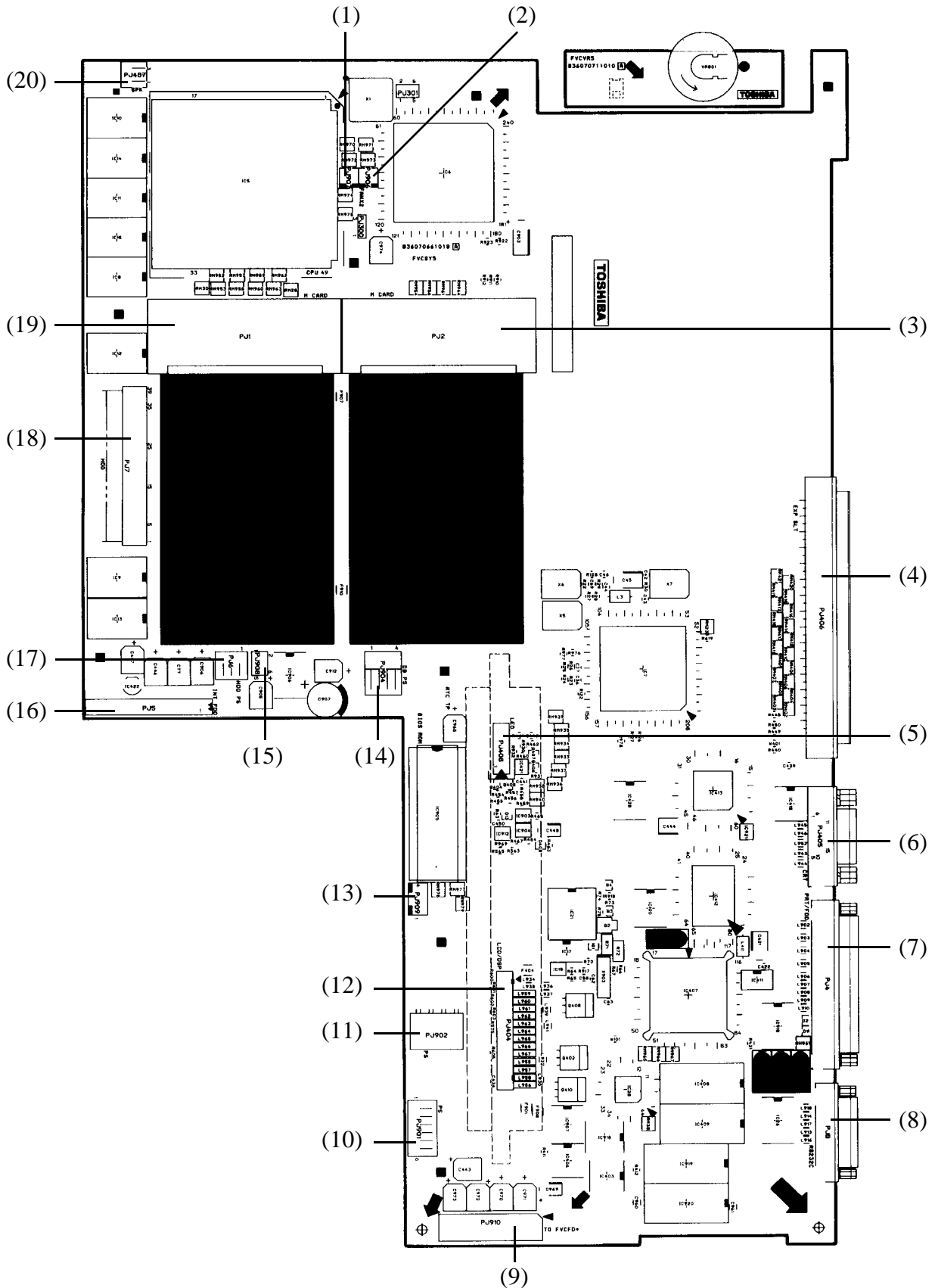
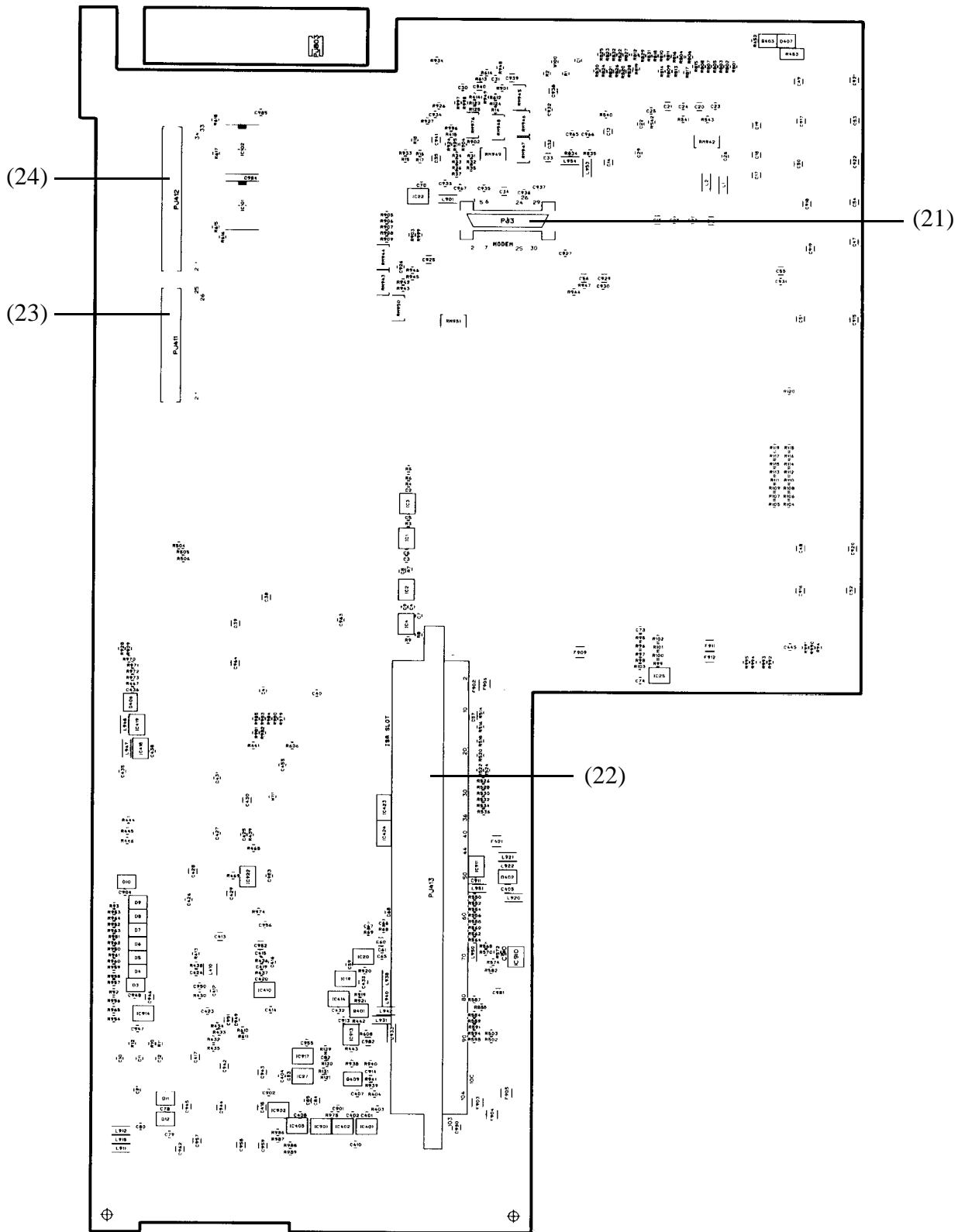

Figure A-3 System board FVCSYx (connectors) (front)





*Table A-2 Connectors on the system board FVCSYx*

| <b>Callout</b> | <b>Number</b> | <b>Name</b>                         |
|----------------|---------------|-------------------------------------|
| (1)            | PJ907         | Fan interface connector             |
| (2)            | PJ906         | Fan interface connector             |
| (3)            | PJ2           | Expansion memory connector          |
| (4)            | PJ406         | Expansion port                      |
| (5)            | PJ408         | LED connector                       |
| (6)            | PJ405         | CRT I/O port                        |
| (7)            | PJ4           | EXT FDD/PRT port                    |
| (8)            | PJ8           | RS-232-C port                       |
| (9)            | PJ910         | I/O board interface connector       |
| (10)           | PJ901         | Power supply connector              |
| (11)           | PJ902         | Power supply connector              |
| (12)           | PJ404         | Display connector                   |
| (13)           | PJ909         | Keyboard connector                  |
| (14)           | PJ904         | CD-ROM/HDD power connector          |
| (15)           | PJ908         | Internal/external FDD select jumper |
| (16)           | PJ5           | FDD interface connector             |
| (17)           | PJ6           | HDD power connector                 |
| (18)           | PJ7           | HDD interface connector             |
| (19)           | PJ1           | Expansion memory connector          |
| (20)           | PJ407         | Speaker connector                   |
| (21)           | PJ3           | Modem interface connector           |
| (22)           | PJ413         | Expansion (ISA) slot connector      |
| (23)           | PJ411         | Feature connector                   |
| (24)           | PJ412         | DVI Support connector               |

### A.3 System Board (FVCSYx) (Oscillators)

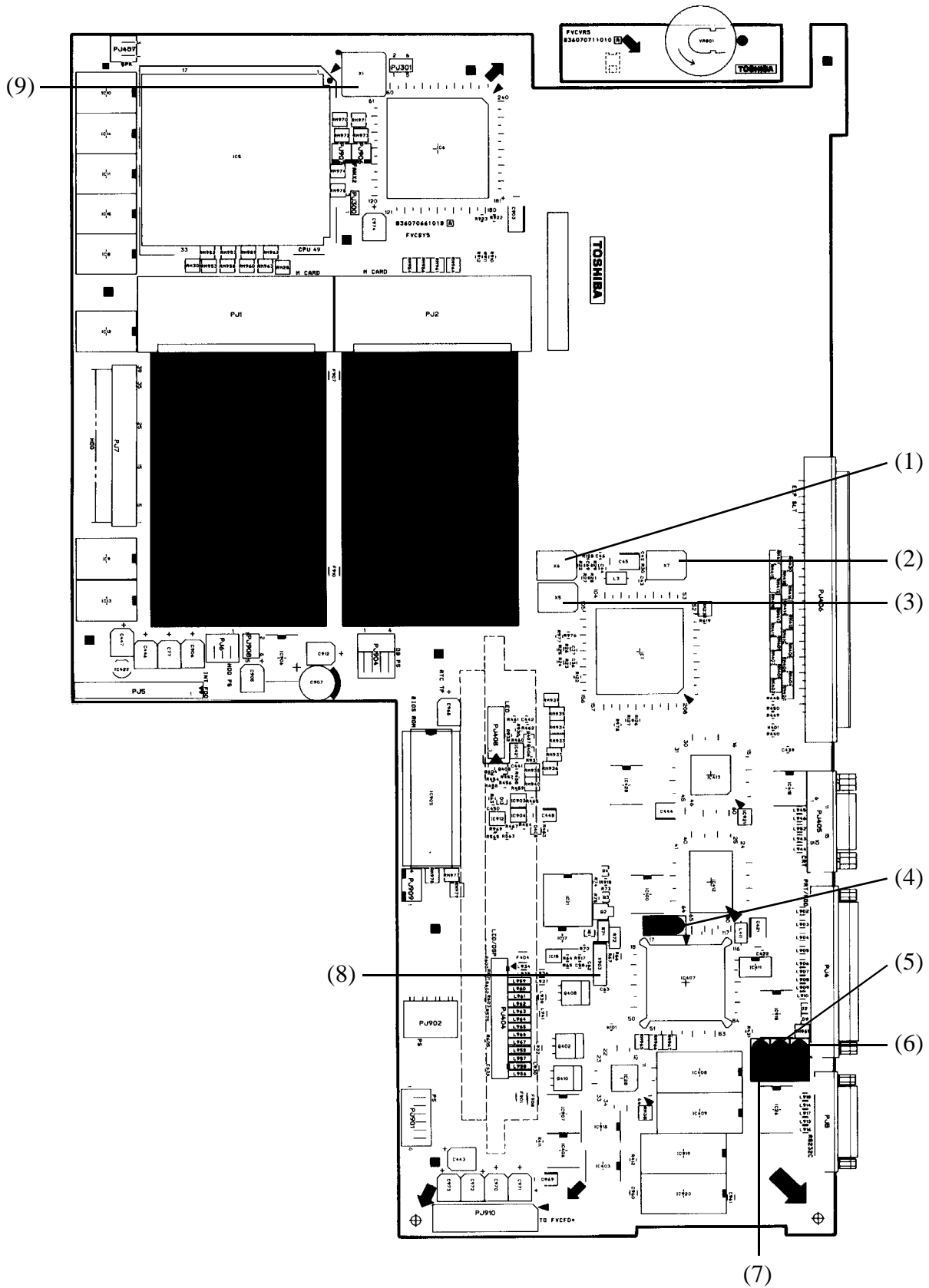

Figure A-5 System board FVCSYx (oscillators) (front)

*Table A-3 Oscillators on the system board FVCSYx*

| <b>Callout</b> | <b>Number</b> | <b>Name</b>                                                         |
|----------------|---------------|---------------------------------------------------------------------|
| (1)            | X6            | 14.7456 MHz for serial O/I controller                               |
| (2)            | X7            | 24 MHz for floppy disk controller and variable frequency oscillator |
| (3)            | X5            | 14.31818 MHz for keyboard controller                                |
| (4)            | X904          | 36.0 MHz for display controller                                     |
| (5)            | X9            | 44.9 MHz for display controller                                     |
| (6)            | X902          | 25.175 MHz for display controller                                   |
| (7)            | X901          | 28.322 MHz for display controller                                   |
| (8)            | X903          | 32.768 KHz for real time clock                                      |
| (9)            | X1            | 33.34 or 25.0 MHz for CPU                                           |

#### **A.4 LED Board (FVCLE<sub>x</sub>)**

*Figure A-7 LED board*

#### **A.5 I/O Interface Board (FVCFD<sub>x</sub>)**

*Figure A-8 I/O interface board*

#### **A.6 Keyboard Scan Controller Board (FVCKB<sub>x</sub>)**

*Figure A-9 Keyboard scan controller board*

# Appendix B Pin Assignments for System Board

## B.1 PJ1 Memory Slot-A Connector (88-Pin)

Table B-1 Memory slot-A connector pin assignment (88-pin)

| Pin | Signal          | I/O | Pin | Signal          | I/O |
|-----|-----------------|-----|-----|-----------------|-----|
| 01  | GND             |     | 45  | GND             |     |
| 02  | D00;100         | I/O | 46  | D16;100         | I/O |
| 03  | D01;100         | I/O | 47  | D17;100         | I/O |
| 04  | D02;100         | I/O | 48  | D18;100         | I/O |
| 05  | D03;100         | I/O | 49  | D19;100         | I/O |
| 06  | D04;100         | I/O | 50  | D20;100         | I/O |
| 07  | D05;100         | I/O | 51  | D21;100         | I/O |
| 08  | D06;100         | I/O | 52  | D22;100         | I/O |
| 09  | VCC             |     | 53  | D23;100         | I/O |
| 10  | D07;100         | I/O | 54  | GND (Pull down) |     |
| 11  | N/C             |     | 55  | GND             |     |
| 12  | GND (Pull down) |     | 56  | GND             |     |
| 13  | MA00;111        | O   | 57  | MA01;111        | O   |
| 14  | MA02;111        | O   | 58  | MA03;111        | O   |
| 15  | VCC             |     | 59  | MA05;111        | O   |
| 16  | MA04;111        | O   | 60  | MA07;111        | O   |
| 17  | N/C             |     | 61  | MA09;111        | O   |
| 18  | MA06;111        | O   | 62  | GND             |     |
| 19  | MA08;111        | O   | 63  | GND             |     |
| 20  | MA10;111        | O   | 64  | GND             |     |
| 21  | GND             |     | 65  | RAS1;000        | O   |
| 22  | RAS0;000        | O   | 66  | CAS2;011        | O   |
| 23  | CAS0;011        | O   | 67  | GND             |     |
| 24  | CAS1;011        | O   | 68  | CAS3;011        | O   |
| 25  | N/C             |     | 69  | RAS3;000        | O   |
| 26  | RAS2;000        | O   | 70  | MEMWE;011       | O   |
| 27  | VCC             |     | 71  | VCC (Pull down) |     |
| 28  | VCC (Pull down) |     | 72  | N/C             |     |
| 29  | N/C             |     | 73  | GND             |     |
| 30  | N/C             |     | 74  | N/C             |     |
| 31  | N/C             |     | 75  | N/C             |     |
| 32  | N/C             |     | 76  | N/C             |     |
| 33  | GND (Pull down) |     | 77  | N/C             |     |
| 34  | D08;100         | I/O | 78  | N/C             |     |
| 35  | N/C             |     | 79  | GND (Pull down) |     |
| 36  | D09;100         | I/O | 80  | D24;100         | I/O |
| 37  | VCC             |     | 81  | D25;100         | I/O |
| 38  | D10;100         | I/O | 82  | D26;100         | I/O |
| 39  | D11;100         | I/O | 83  | D27;100         | I/O |
| 40  | D12;100         | I/O | 84  | D28;100         | I/O |
| 41  | D13;100         | I/O | 85  | D29;100         | I/O |
| 42  | D14;100         | I/O | 86  | D30;100         | I/O |
| 43  | D15;100         | I/O | 87  | D31;100         | I/O |
| 44  | GND             |     | 88  | GND             |     |

## B.2 PJ2 Memory Slot-B Connector (88-Pin)

Table B-2 Memory slot-B connector pin assignment (88-pin)

| Pin | Signal          | I/O | Pin | Signal          | I/O |
|-----|-----------------|-----|-----|-----------------|-----|
| 01  | GND             |     | 45  | GND             |     |
| 02  | D00;100         | I/O | 46  | D16;100         | I/O |
| 03  | D01;100         | I/O | 47  | D17;100         | I/O |
| 04  | D02;100         | I/O | 48  | D18;100         | I/O |
| 05  | D03;100         | I/O | 49  | D19;100         | I/O |
| 06  | D04;100         | I/O | 50  | D20;100         | I/O |
| 07  | D05;100         | I/O | 51  | D21;100         | I/O |
| 08  | D06;100         | I/O | 52  | D22;100         | I/O |
| 09  | VCC             |     | 53  | D23;100         | I/O |
| 10  | D07;100         | I/O | 54  | GND (Pull down) |     |
| 11  | N/C             |     | 55  | GND             |     |
| 12  | GND (Pull down) |     | 56  | GND             |     |
| 13  | MA00;112        | O   | 57  | MA01;112        | O   |
| 14  | MA02;112        | O   | 58  | MA03;112        | O   |
| 15  | VCC             |     | 59  | MA05;112        | O   |
| 16  | MA04;112        | O   | 60  | MA07;112        | O   |
| 17  | N/C             |     | 61  | MA09;112        | O   |
| 18  | MA06;112        | O   | 62  | GND             |     |
| 19  | MA08;112        | O   | 63  | GND             |     |
| 20  | MA10;112        | O   | 64  | GND             |     |
| 21  | GND             |     | 65  | RAS5;000        | O   |
| 22  | RAS4;000        | O   | 66  | CAS2;012        | O   |
| 23  | CAS0;012        | O   | 67  | GND             |     |
| 24  | CAS1;012        | O   | 68  | CAS3;012        | O   |
| 25  | N/C             |     | 69  | RAS7;000        | O   |
| 26  | RAS6;000        | O   | 70  | MEMWE;012       | O   |
| 27  | VCC             |     | 71  | VCC (Pull down) |     |
| 28  | VCC (Pull down) |     | 72  | N/C             |     |
| 29  | N/C             |     | 73  | GND             |     |
| 30  | N/C             |     | 74  | N/C             |     |
| 31  | N/C             |     | 75  | N/C             |     |
| 32  | N/C             |     | 76  | N/C             |     |
| 33  | GND             |     | 77  | N/C             |     |
| 34  | D08;100         | I/O | 78  | N/C             |     |
| 35  | N/C             |     | 79  | GND (Pull down) |     |
| 36  | D09;100         | I/O | 80  | D24;100         | I/O |
| 37  | VCC             |     | 81  | D25;100         | I/O |
| 38  | D10;100         | I/O | 82  | D26;100         | I/O |
| 39  | D11;100         | I/O | 83  | D27;100         | I/O |
| 40  | D12;100         | I/O | 84  | D28;100         | I/O |
| 41  | D13;100         | I/O | 85  | D29;100         | I/O |
| 42  | D14;100         | I/O | 86  | D30;100         | I/O |
| 43  | D15;100         | I/O | 87  | D31;100         | I/O |
| 44  | GND             |     | 88  | GND             |     |

### B.3 PJ3 Modem Connector (30-Pin)

Table B-3 Modem connector pin assignment (30-pin)

| Pin | Signal      | I/O | Pin | Signal     | I/O |
|-----|-------------|-----|-----|------------|-----|
| 01  | M9V         | O   | 16  | GND        |     |
| 02  | BMDMSL;000  | I/O | 17  | SD02;100   | I/O |
| 03  | \$14R7M;003 | O   | 18  | SD01;100   | I/O |
| 04  | SA00;100    | I/O | 19  | GND        |     |
| 05  | GND         |     | 20  | GND        |     |
| 06  | SA01;100    | I/O | 21  | SD00;100   | I/O |
| 07  | SA02;100    | I/O | 22  | IOW;000    | I/O |
| 08  | GND         |     | 23  | IOR;100    | I/O |
| 09  | SD07;100    | I/O | 24  | VCC        |     |
| 10  | SD06;100    | I/O | 25  | RESET;100  | O   |
| 11  | GND         |     | 26  | VCC        |     |
| 12  | GND         |     | 27  | BMPOFF;100 | O   |
| 13  | SD05;100    | I/O | 28  | VCC        |     |
| 14  | SD04;100    | I/O | 29  | BMIRQ;000  | I   |
| 15  | SD03;100    | I/O | 30  | BSPTON;000 | I   |

### B.4 PJ4 EXT FDD/PRT Connector (25-Pin)

Table B-4 EXT FDD/PRT connector pin assignment (25-pin)

| Pin | Signal     | I/O | Pin | Signal    | I/O |
|-----|------------|-----|-----|-----------|-----|
| 01  | STROB;000  | I/O | 14  | AUTFD;000 | I/O |
| 02  | PDB00;100  | I/O | 15  | ERROR;000 | I/O |
| 03  | PDB01;100  | I/O | 16  | PINIT;000 | I/O |
| 04  | PDB02;100  | I/O | 17  | SLIN;000  | I/O |
| 05  | PDB03;100  | I/O | 18  | GND       |     |
| 06  | PDB04;100  | I/O | 19  | GND       |     |
| 07  | PDB05;100  | I/O | 20  | GND       |     |
| 08  | PDB06;100  | I/O | 21  | GND       |     |
| 09  | PDB07;100  | I/O | 22  | GND       |     |
| 10  | ACK;000    | I/O | 23  | GND       |     |
| 11  | BUSY;100   | I/O | 24  | GND       |     |
| 12  | PE;110     | I/O | 25  | GND       |     |
| 13  | SELECT;100 | I/O | --- | ---       | --- |

## B.5 PJ5 INT FDD Connector (26-Pin)

Table B-5 INT FDD connector pin assignment (26-pin)

| Pin | Signal     | I/O | Pin | Signal    | I/O |
|-----|------------|-----|-----|-----------|-----|
| 01  | VCC        |     | 14  | ISTEP;000 | O   |
| 02  | IINDEX;000 | I   | 15  | GND       |     |
| 03  | VCC        |     | 16  | IWDAT;000 | O   |
| 04  | IDSL;010   | O   | 17  | GND       |     |
| 05  | VCC        |     | 18  | IWEN;010  | O   |
| 06  | DSKCHG;000 | I   | 19  | GND       |     |
| 07  | VCC        |     | 20  | ITRO;000  | I   |
| 08  | IRDY;000   | I   | 21  | GND       |     |
| 09  | IHMED;000  | I   | 22  | IWPR;000  | I   |
| 10  | IMON;000   | O   | 23  | GND       |     |
| 11  | ILOWD;000  | O   | 24  | IRDAT;000 | I   |
| 12  | IDIRC;000  | O   | 25  | GND       |     |
| 13  | GND        |     | 26  | ISSEL;000 | O   |

## B.6 PJ6 HDD Power Connector (3-Pin)

Table B-6 HDD power connector pin assignment (3-pin)

| Pin | Signal | I/O | Pin | Signal | I/O |
|-----|--------|-----|-----|--------|-----|
| 01  | P12V1  | O   | 03  | VCC    |     |
| 02  | GND    |     | --- | ---    | --- |

## B.7 PJ904 CD-ROM/HDD Power Connector (4-Pin)

Table B-7 CD-ROM/HDD power connector pin assignment (4-pin)

| Pin | Signal | I/O | Pin | Signal | I/O |
|-----|--------|-----|-----|--------|-----|
| 01  | P12V1  | O   | 03  | GND    |     |
| 02  | GND    |     | 04  | VCC    |     |



## B.8 PJ7 HDD I/F Connector (40-Pin)

Table B-8 HDD I/F connector pin assignment (40-pin)

| Pin | Signal    | I/O | Pin | Signal     | I/O |
|-----|-----------|-----|-----|------------|-----|
| 01  | HRST;000  |     | 21  | N/C        |     |
| 02  | GND       |     | 22  | GND        |     |
| 03  | HSD07;100 | I/O | 23  | HIOW;000   | O   |
| 04  | HSD08;100 | I/O | 24  | GND        |     |
| 05  | HSD06;100 | I/O | 25  | HIOR;000   | O   |
| 06  | HSD09;100 | I/O | 26  | GND        |     |
| 07  | HSD05;100 | I/O | 27  | CHRDY;100  | I   |
| 08  | HSD10;100 | I/O | 28  | HBALE;100  | O   |
| 09  | HSD04;100 | I/O | 29  | N/C        |     |
| 10  | HSD11;100 | I/O | 30  | GND        |     |
| 11  | HSD03;100 | I/O | 31  | IRQ14;100  | I   |
| 12  | HSD12;100 | I/O | 32  | IO16;100   | I   |
| 13  | HSD02;100 | I/O | 33  | HSA01;100  | O   |
| 14  | HSD13;100 | I/O | 34  | N/C        |     |
| 15  | HSD01;100 | I/O | 35  | HAS00;100  | O   |
| 16  | HSD14;100 | I/O | 36  | HAS02;100  | O   |
| 17  | HSD00;100 | I/O | 37  | HCD0CS;020 | O   |
| 18  | HSD15;100 | I/O | 38  | HDC1CS;020 | O   |
| 19  | GND       |     | 39  | HDDLED;000 | I   |
| 20  | VCC       |     | 40  | GND        |     |

## B.9 PJ8 RS-232-C Connector (9-Pin)

Table B-9 RS-232-C connector pin assignment (9-pin)

| Pin | Signal   | I/O | Pin | Signal   | I/O |
|-----|----------|-----|-----|----------|-----|
| 01  | DCD1;111 | O   | 06  | DSR1;111 | O   |
| 02  | RD1;011  | O   | 07  | RTS1;111 | O   |
| 03  | SD1;011  | O   | 08  | CTS1;111 | O   |
| 04  | DTR1;111 | O   | 09  | RI1;111  | O   |
| 05  | GND      |     | --- | ---      | --- |

## B.10 PJ404 Display Connector (34-Pin)

Table B-10 Display connector pin assignment (34-pin)

| Pin | Signal    | I/O | Pin | Signal     | I/O |
|-----|-----------|-----|-----|------------|-----|
| 01  | P24V      | O   | 18  | GND        |     |
| 02  | P24V      | O   | 19  | PLTB1;120  | O   |
| 03  | GND       |     | 20  | GND        |     |
| 04  | GND       |     | 21  | PLTB2;120  | O   |
| 05  | PLTR0;120 | O   | 22  | GND        |     |
| 06  | GND       |     | 23  | DFLTCK;120 | O   |
| 07  | PLTR1;120 | O   | 24  | GND        |     |
| 08  | GND       |     | 25  | DLP;120    | O   |
| 09  | PLTR2;120 | O   | 26  | DFP;120    | O   |
| 10  | GND       |     | 27  | DENAB;120  | O   |
| 11  | PLTG0;120 | O   | 28  | GND        |     |
| 12  | GND       |     | 29  | PNEL0;100  | O   |
| 13  | PLTG1;120 | O   | 30  | PNEL1;100  | O   |
| 14  | GND       |     | 31  | GND        |     |
| 15  | PLTG2;120 | O   | 32  | GND        |     |
| 16  | GND       |     | 33  | VCC        | O   |
| 17  | PLTB0;120 | O   | 34  | P12V1      | O   |

## B.11 PJ405 CRT I/O Connector (15-Pin)

Table B-11 CRT I/O connector pin assignment (15-pin)

| Pin | Signal     | I/O | Pin | Signal | I/O |
|-----|------------|-----|-----|--------|-----|
| 01  | CRED;110   | O   | 09  | N/C    |     |
| 02  | CGREEN;110 | O   | 10  | GND    |     |
| 03  | CBLUE;110  | O   | 11  | N/C    |     |
| 04  | N/C        |     | 12  | N/C    |     |
| 05  | GND        |     | 13  | LP;120 | O   |
| 06  | GND        |     | 14  | FP;120 | O   |
| 07  | GND        |     | 15  | N/C    |     |
| 08  | GND        |     | --- | ---    | --- |

## B.12 PJ406 Expansion Connector (150-Pin)

Table B-12 Expansion connector pin assignment (150-pin)

| Pin | Signal      | I/O | Pin | Signal       | I/O |
|-----|-------------|-----|-----|--------------|-----|
| 01  | N/C         |     | 49  | SD07;101     | I/O |
| 02  | N/C         |     | 50  | SMEW;001     | O   |
| 03  | N/C         |     | 51  | SMER;001     | O   |
| 04  | N/C         |     | 52  | GND          |     |
| 05  | N/C         |     | 53  | IOW;001      | I/O |
| 06  | N/C         |     | 54  | IOR;001      | I/O |
| 07  | N/C         |     | 55  | TC;101       | O   |
| 08  | N/C         |     | 56  | BALE;101     | O   |
| 09  | N/C         |     | 57  | RESET;101    | O   |
| 10  | GND         |     | 58  | DACK1;001    | O   |
| 11  | RVCC        |     | 59  | IRQ9;101     | I   |
| 12  | RGND        |     | 60  | GND          |     |
| 13  | PCNF;101    | I   | 61  | N/C          |     |
| 14  | MDMSL;001   | O   | 62  | \$\$YSCK;121 | O   |
| 15  | \$14R7M;022 | O   | 63  | IRQ5;101     | I   |
| 16  | MIRQ;001    | I   | 64  | DRQ3;101     | I   |
| 17  | SPKTON;001  | I   | 65  | DACK3;001    | O   |
| 18  | GND         |     | 66  | AEN;101      | O   |
| 19  | SA00;101    | I/O | 67  | DRQ1;101     | I   |
| 20  | SA01;101    | I/O | 68  | IOCRDY;101   | I   |
| 21  | SA02;101    | I/O | 69  | GND          |     |
| 22  | SA03;101    | I/O | 70  | IRQ10;101    | I   |
| 23  | SA04;101    | I/O | 71  | IRQ14;101    | I   |
| 24  | SA05;101    | I/O | 72  | SD08;101     | I/O |
| 25  | SA06;101    | I/O | 73  | SD09;101     | I/O |
| 26  | SA07;101    | I/O | 74  | IRQ11;101    | I   |
| 27  | GND         |     | 75  | SD10;101     | I/O |
| 28  | SA08;101    | I/O | 76  | SD11;101     | I/O |
| 29  | SA09;101    | I/O | 77  | SD12;101     | I/O |
| 30  | SA10;101    | I/O | 78  | IRQ12;101    | I   |
| 31  | SA11;101    | I/O | 79  | GND          |     |
| 32  | SA12;101    | I/O | 80  | SD13;101     | I/O |
| 33  | SA13;101    | I/O | 81  | SD14;101     | I/O |
| 34  | SA14;101    | I/O | 82  | IRQ6;101     | I   |
| 35  | SA15;101    | I/O | 83  | SD15;101     | I/O |
| 36  | GND         |     | 84  | LA22;101     | I/O |
| 37  | SA16;101    | I/O | 85  | SA23;101     | I/O |
| 38  | SA17;101    | I/O | 86  | DRQ2;101     | I   |
| 39  | SA18;101    | I/O | 87  | LA21;101     | I/O |
| 40  | SA19;101    | I/O | 88  | LA19;101     | I/O |
| 41  | SD00;101    | I/O | 89  | LA20;101     | I/O |
| 42  | SD01;101    | I/O | 90  | DACK6;001    | O   |
| 43  | SD02;101    | I/O | 91  | GND          |     |
| 44  | SD03;101    | I/O | 92  | REFMD;001    | I/O |
| 45  | GND         |     | 93  | LA18;101     | I/O |
| 46  | SD04;101    | I/O | 94  | MASTER;001   | O   |
| 47  | SD05;101    | I/O | 95  | LA17;101     | I/O |
| 48  | SD06;101    | I/O | 96  | SBHE;001     | I/O |

*Table B-12 Expansion connector pin assignment (150-pin) (continued)*

| Pin | Signal     | I/O | Pin | Signal    | I/O |
|-----|------------|-----|-----|-----------|-----|
| 97  | IOCHCK;001 | O   | 124 | PDB00;100 | I/O |
| 98  | MMCS16;001 | O   | 125 | PDB01;100 | I/O |
| 99  | GND        |     | 126 | PDB02;100 | I/O |
| 100 | IOCS16;001 | O   | 127 | PDB03;100 | I/O |
| 101 | DACK2;001  | O   | 128 | PDB04;100 | I/O |
| 102 | DRQ6;101   | I   | 129 | PDB05;100 | I/O |
| 103 | DRQ5;101   | I   | 130 | PDB06;100 | I/O |
| 104 | DACK5;001  | O   | 131 | PDB07;100 | I/O |
| 105 | MEMR;001   | I/O | 132 | ACK;000   | I/O |
| 106 | IRQ4;101   | I   | 133 | BUSY;100  | I/O |
| 107 | MEMW;001   | I/O | 134 | PE;100    | I/O |
| 108 | IRQ7;101   | I   | 135 | SELCT;100 | I/O |
| 109 | GND        |     | 136 | AUTFD;000 | I/O |
| 110 | CRED;100   | O   | 137 | ERROR;000 | I/O |
| 111 | CGREEN;100 | O   | 138 | PINIT;000 | I/O |
| 112 | CBLUE;100  | O   | 139 | SLIN;000  | I/O |
| 113 | GND        |     | 140 | GND       |     |
| 114 | LP;110     | O   | 141 | SD1;000   | I   |
| 115 | FP;110     | O   | 142 | DTR1;100  | I   |
| 116 | GND        |     | 143 | RTS1;100  | I   |
| 117 | EXKBDT;100 | I/O | 144 | DCD1;100  | O   |
| 118 | EXKBCK;100 | I/O | 145 | RD1;000   | O   |
| 119 | N/C        |     | 146 | DSR1;100  | O   |
| 120 | MUSDAT;130 | I/O | 147 | CTS1;100  | O   |
| 121 | MUSCLK;020 | I/O | 148 | RI1;100   | O   |
| 122 | GND        |     | 149 | GND       |     |
| 123 | STROB;000  | I/O | 150 | GND       |     |

### **B.13 PJ407 Speaker I/F Connector (2-Pin)**

*Table B-13 Speaker I/F connector pin assignment (2-pin)*

| Pin | Signal  | I/O | Pin | Signal  | I/O |
|-----|---------|-----|-----|---------|-----|
| 01  | SPK;140 | O   | 02  | SPK;121 | O   |

### **B.14 PJ408 LED I/F Connector (8-Pin)**

*Table B-14 LED I/F connector pin assignment (8-pin)*

| Pin | Signal     | I/O | Pin | Signal     | I/O |
|-----|------------|-----|-----|------------|-----|
| 01  | RTCBT;100  | I   | 05  | FDDLED;100 | O   |
| 02  | GND        |     | 06  | HDDLED;100 | O   |
| 03  | PNLOFF;000 | I   | 07  | HISPD;100  | O   |
| 04  | GND        |     | 08  | LOWSPD;100 | O   |

## B.15 PJ411 Feature Connector (26-Pin)

Table B-15 Feature connector pin assignment (26-pin)

| Pin | Signal     | I/O | Pin | Signal   | I/O |
|-----|------------|-----|-----|----------|-----|
| 01  | SLD0;100   | O   | 14  | N/C      |     |
| 02  | FEASEN;100 | I   | 15  | SUD3;100 | O   |
| 03  | SLD1;100   | O   | 16  | GND      |     |
| 04  | GND        |     | 17  | PCLK;100 | O   |
| 05  | SLD2;100   | O   | 18  | GND      |     |
| 06  | GND        |     | 19  | FR;100   | O   |
| 07  | SLD3;100   | O   | 20  | GND      |     |
| 08  | N/C        |     | 21  | LP;100   | O   |
| 09  | SUD0;100   | O   | 22  | GND      |     |
| 10  | N/C        |     | 23  | FP;100   | O   |
| 11  | SUD1;100   | O   | 24  | N/C      |     |
| 12  | N/C        |     | 25  | GND      |     |
| 13  | SUD2;100   | O   | 26  | N/C      |     |

## B.16 PJ412 DVI Support Connector (34-Pin)

Table B-16 DVI support connector pin assignment (34-pin)

| Pin | Signal    | I/O | Pin | Signal     | I/O |
|-----|-----------|-----|-----|------------|-----|
| 01  | DACR0;100 | I   | 18  | GND        |     |
| 02  | DACR1;100 | I   | 19  | DACB0;100  | I   |
| 03  | GND       |     | 20  | DACB1;100  | I   |
| 04  | DACR2;100 | I   | 21  | GND        |     |
| 05  | DACR3;100 | I   | 22  | DACB2;100  | I   |
| 06  | GND       |     | 23  | DACB3;100  | I   |
| 07  | DACR4;100 | I   | 24  | GND        |     |
| 08  | DACR5;100 | I   | 25  | DACB4;100  | I   |
| 09  | GND       |     | 26  | DACB5;100  | I   |
| 10  | DACG0;100 | I   | 27  | GND        |     |
| 11  | DACG1;100 | I   | 28  | LLP;100    | I   |
| 12  | GND       |     | 29  | LFP;100    | I   |
| 13  | DACG2;100 | I   | 30  | GND        |     |
| 14  | DACG3;100 | I   | 31  | GND        |     |
| 15  | GND       |     | 32  | LWCLK;100  | I   |
| 16  | DACG4;100 | I   | 33  | LPCLK;100  | I   |
| 17  | DACG5;100 | I   | 34  | ZENSEN;000 | I   |

## B.17 PJ413 ISA Slot Connector (104-Pin)

Table B-17 ISA slot connector pin assignment (104-pin)

| Pin | Signal        | I/O | Pin | Signal        | I/O |
|-----|---------------|-----|-----|---------------|-----|
| 01  | SD15;102      | I/O | 53  | SA05;102      |     |
| 02  | GND           |     | 54  | DACK2;002     | O   |
| 03  | SD14;102      | I/O | 55  | SA06;102      | I/O |
| 04  | MASTER;002    | I   | 56  | IRQ3;102      | I   |
| 05  | SD13;102      | I/O | 57  | SA07;102      | I/O |
| 06  | VCC           |     | 58  | IRQ4;102      | I   |
| 07  | SD12;102      | I/O | 59  | SA08;102      | I/O |
| 08  | DRQ7;102      | I   | 60  | IRQ5;102      | I   |
| 09  | SD11;102      | I/O | 61  | SA09;102      | I/O |
| 10  | DACK7;002     | O   | 62  | IRQ6;102      | I   |
| 11  | SD10;102      | I/O | 63  | SA10;102      | I/O |
| 12  | DRQ6;102      | I   | 64  | IRQ7;102      | I   |
| 13  | SD09;102      | I/O | 65  | SA11;102      | I/O |
| 14  | DACK6;002     | O   | 66  | \$\$SYSCK;122 | O   |
| 15  | SD08;102      | I/O | 67  | SA12;102      | I/O |
| 16  | DRQ5;102      | I   | 68  | REFMD;002     | I/O |
| 17  | MEMW;002      | I/O | 69  | SA13;102      | I/O |
| 18  | DACK5;002     | O   | 70  | DRQ1;102      | I   |
| 19  | MEMR;002      | I/O | 71  | SA14;102      | I/O |
| 20  | DRQD;102      | I   | 72  | DACK1;002     | O   |
| 21  | LA17;102      | I/O | 73  | SA15;102      | I/O |
| 22  | DACK0;002     | O   | 74  | DRQ3;102      | I   |
| 23  | LA18;102      | I/O | 75  | SA16;102      | I/O |
| 24  | IRQ14;102     | I   | 76  | DACK3;002     | O   |
| 25  | LA19;102      | I/O | 77  | SA17;102      | I/O |
| 26  | IRQ15;102     | I   | 78  | IOR;002       | I/O |
| 27  | LA20;102      | I/O | 79  | SA18;102      | I/O |
| 28  | IRQ12;102     | I   | 80  | IOW;002       | I/O |
| 29  | LA21;102      | I/O | 81  | SA19;102      | I/O |
| 30  | IRQ11;102     | I   | 82  | SMER;002      | O   |
| 31  | LA22;102      | I/O | 83  | \$\$DMACK;122 | O   |
| 32  | IRQ10;102     | I   | 84  | SMEW;002      | O   |
| 33  | LA23;102      | I/O | 85  | IOCRDY;102    | I   |
| 34  | IOCS16;002    | I   | 86  | GND           |     |
| 35  | SBHE;002      | I/O | 87  | SD00;102      | I/O |
| 36  | MMCS16;002    | I   | 88  | P12V2         | O   |
| 37  | N/C           |     | 89  | SD01;102      | I/O |
| 38  | N/C           |     | 90  | N/C           |     |
| 39  | N/C           |     | 91  | SD02;102      | I/O |
| 40  | N/C           |     | 92  | M12V          | O   |
| 41  | N/C           |     | 93  | SD03;102      | I/O |
| 42  | N/C           |     | 94  | DRQ2;102      | I   |
| 43  | SA00;102      | I/O | 95  | SD04;102      | I/O |
| 44  | GND           |     | 96  | M5V           | O   |
| 45  | SA01;102      | I/O | 97  | SD05;102      | I/O |
| 46  | \$\$14R3M;022 | O   | 98  | IRQ;102       | I   |
| 47  | SA02;102      | I/O | 99  | SD06;102      | I/O |
| 48  | VCC           |     | 100 | VCC           |     |
| 49  | SA03;102      | I/O | 101 | SD07;102      | I/O |
| 50  | BALE;102      | O   | 102 | RESET;102     | O   |
| 51  | SA04;102      | I/O | 103 | IOCHK;002     | I   |
| 52  | TC;102        | O   | 104 | GND           |     |

### B.18 PJ901 PS I/F Connector (6-Pin)

Table B-18 PS I/F connector pin assignment (6-pin)

| Pin | Signal | I/O | Pin | Signal | I/O |
|-----|--------|-----|-----|--------|-----|
| 01  | P12V1  | I   | 04  | M5V    | I   |
| 02  | P12V1  | I   | 05  | M12V   | I   |
| 03  | P12V2  | I   | 06  | P24V   | I   |

### B.19 PJ902 PS I/F Connector (4-Pin)

Table B-19 PS I/F connector pin assignment (4-pin)

| Pin | Signal | I/O | Pin | Signal | I/O |
|-----|--------|-----|-----|--------|-----|
| 01  | VCC    |     | 03  | GND    |     |
| 02  | VCC    |     | 04  | GND    |     |

### B.20 PJ906 Fan I/F Connector (2-Pin)

Table B-20 Fan I/F connector pin assignment (2-pin)

| Pin | Signal | I/O | Pin | Signal | I/O |
|-----|--------|-----|-----|--------|-----|
| 01  | P12V1  | I   | 02  | GND    |     |

### B.21 PJ907 Fan I/F Connector (2-Pin)

Table B-21 Fan I/F connector pin assignment (2-pin)

| Pin | Signal | I/O | Pin | Signal | I/O |
|-----|--------|-----|-----|--------|-----|
| 01  | P12V1  | I   | 02  | GND    |     |

### B.22 PJ909 Int. KB Connector (4-Pin)

Table B-22 Int KB connector pin assignment (4-pin)

| Pin | Signal     | I/O | Pin | Signal    | I/O |
|-----|------------|-----|-----|-----------|-----|
| 01  | KBFVCC;100 | O   | 03  | GND       |     |
| 02  | KBDAT;130  | O   | 04  | KBCLK;020 | O   |

## B.23 PJ910 I/O Board I/F Connector (40-Pin)

Table B-23 I/O board I/F connector pin assignment (40-pin)

| Pin | Signal     | I/O | Pin | Signal     | I/O |
|-----|------------|-----|-----|------------|-----|
| 01  | EXKBCK;100 | I/O | 21  | ISTEP;000  | I   |
| 02  | GND        |     | 22  | GND        |     |
| 03  | EXKBDT;100 | I/O | 23  | IDIRC;000  | I   |
| 04  | VCC        |     | 24  | VCC        |     |
| 05  | MUSDAT;130 | I/O | 25  | ILOWD;000  | I   |
| 06  | GND        |     | 26  | GND        |     |
| 07  | MUSCLK;020 | I/O | 27  | IMON;000   | I   |
| 08  | VCC        |     | 28  | VCC        |     |
| 09  | ISSEL;000  | I   | 29  | IHMED;000  | O   |
| 10  | GND        |     | 30  | GND        |     |
| 11  | IRDAT;000  | O   | 31  | IRDY;000   | O   |
| 12  | VCC        |     | 32  | VCC        |     |
| 13  | IWPR;000   | O   | 33  | DSKCHG;000 | O   |
| 14  | GND        |     | 34  | GND        |     |
| 15  | ITRO;000   | O   | 35  | IDSL;011   | I   |
| 16  | VCC        |     | 36  | VCC        |     |
| 17  | IWEN;011   | I   | 37  | IINDEX;000 | I   |
| 18  | GND        |     | 38  | GND        |     |
| 19  | IWDAT;000  | I   | 39  | GND        |     |
| 20  | VCC        |     | 40  | VCC        |     |



# Appendix C ASCII Character Codes

Table C-1 ASCII character codes

| HEXA-DECIMAL VALUE | 0            | 1  | 2             | 3 | 4 | 5 | 6 | 7 | 8 | 9  | A | B | C | D | E | F        |
|--------------------|--------------|----|---------------|---|---|---|---|---|---|----|---|---|---|---|---|----------|
| 0                  | BLANK (NULL) | ▶  | BLANK (SPACE) | 0 | @ | P | • | p | Ç | É  | á | ⋮ | ┌ | └ | α | ε        |
| 1                  | 😊            | ◀  | !             | 1 | A | Q | a | q | ü | æ  | í | ⋮ | ┌ | └ | β | ±        |
| 2                  | 😁            | ↑  | “             | 2 | B | R | b | r | é | Æ  | ó | ⋮ | ┌ | └ | Γ | ≥        |
| 3                  | ♥            | !! | #             | 3 | C | S | c | s | â | ô  | ú | ┌ | └ | ┌ | π | ≤        |
| 4                  | ♦            | ¶  | \$            | 4 | D | T | d | t | ä | ö  | ñ | ┌ | └ | ┌ | Σ | f        |
| 5                  | ♣            | §  | %             | 5 | E | U | e | u | à | ò  | Ñ | ┌ | └ | ┌ | σ | J        |
| 6                  | ♠            | —  | &             | 6 | F | V | f | v | å | û  | ä | ┌ | └ | ┌ | μ | ÷        |
| 7                  | ●            | ↓  | '             | 7 | G | W | g | w | ç | ù  | ó | ┌ | └ | ┌ | γ | ≈        |
| 8                  | ●            | ↑  | (             | 8 | H | X | h | x | ê | ÿ  | ¿ | ┌ | └ | ┌ | Φ | °        |
| 9                  | ○            | ↓  | )             | 9 | I | Y | i | y | ë | Ö  | ┌ | └ | ┌ | ┌ | Θ | ■        |
| A                  | ●            | →  | *             | : | J | Z | j | z | è | Ü  | ┌ | └ | ┌ | ┌ | Ω | —        |
| B                  | ♂            | ←  | +             | ; | K | [ | k | { | ï | ç  | ½ | ┌ | └ | ■ | δ | √        |
| C                  | ♀            | ┌  | ,             | < | L | \ | l |   | î | £  | ¼ | ┌ | └ | ■ | φ | n        |
| D                  | ♪            | ↔  | -             | = | M | ] | m | } | ì | ¥  | ı | ┌ | └ | ■ | φ | 2        |
| E                  | ♪            | ▲  | ▪             | > | N | ^ | n | ~ | Ä | Pt | « | ┌ | └ | ■ | € | ■        |
| F                  | ⚙            | ▼  | /             | ? | O | - | o | 🏠 | Å | f  | » | ┌ | └ | ■ | ∩ | BLANK FF |

# Appendix D Keyboard Scan/Character Codes

Table D-1 KB code to ASCII code conversion table

| Cap No. | Key Top    | Lower Case | Upper Case | Caps Lock |       | With (Ctrl) | With (Alt) |
|---------|------------|------------|------------|-----------|-------|-------------|------------|
|         |            |            |            | Lower     | Upper |             |            |
| 01      | ~<br>`     | 29 60      | 29 7E      | 29 60     | 29 7E | -           | 29 00      |
|         |            | 29 60      | 29 7E      | 29 60     | 29 7E | -           | -          |
| 02      | !<br>1     | 02 31      | 02 21      | 02 31     | 02 21 | -           | 78 00      |
|         |            | 02 31      | 02 21      | 02 31     | 02 21 | -           | 78 00      |
| 03      | @<br>2     | 03 32      | 03 40      | 03 32     | 03 40 | 03 00       | 79 00      |
|         |            | 03 32      | 03 40      | 03 32     | 03 40 | 03 00       | 79 00      |
| 04      | #<br>3     | 04 33      | 04 23      | 04 33     | 04 23 | -           | 7A 00      |
|         |            | 04 33      | 04 23      | 04 33     | 04 23 | -           | 7A 00      |
| 05      | \$<br>4    | 05 34      | 05 24      | 05 34     | 05 24 | -           | 7B 00      |
|         |            | 05 34      | 05 24      | 05 34     | 05 24 | -           | 7B 00      |
| 06      | %<br>5     | 06 35      | 06 25      | 06 35     | 06 25 | -           | 7C 00      |
|         |            | 06 35      | 06 25      | 06 35     | 06 25 | -           | 7C 00      |
| 07      | ^<br>6     | 07 36      | 07 5E      | 07 36     | 07 5E | 07 1E       | 7D 00      |
|         |            | 07 36      | 07 5E      | 07 36     | 07 5E | 07 1E       | 7D 00      |
| 08      | &<br>7     | 08 37      | 08 26      | 08 37     | 08 26 | -           | 7E 00      |
|         |            | 08 37      | 08 26      | 08 37     | 08 26 | -           | 7E 00      |
| 09      | *<br>8     | 09 38      | 09 2A      | 09 38     | 09 2A | -           | 7F 00      |
|         |            | 09 38      | 09 2A      | 09 38     | 09 2A | -           | 7F 00      |
| 10      | ( )<br>9   | 0A 39      | 0A 28      | 0A 39     | 0A 28 | -           | 80 00      |
|         |            | 0A 39      | 0A 28      | 0A 39     | 0A 28 | -           | 80 00      |
| 11      | ) )<br>0   | 0B 30      | 0B 29      | 0B 30     | 0B 29 | -           | 81 00      |
|         |            | 0B 30      | 0B 29      | 0B 30     | 0B 29 | -           | 81 00      |
| 12      | -<br>-     | 0C 2D      | 0C 5F      | 0C 2D     | 0C 5F | 0C 1F       | 82 00      |
|         |            | 0C 2D      | 0C 5F      | 0C 2D     | 0C 5F | 0C 1F       | 82 00      |
| 13      | +<br>=     | 0D 3D      | 0D 2B      | 0D 3D     | 0D 2B | -           | 83 00      |
|         |            | 0D 3D      | 0D 2B      | 0D 3D     | 0D 2B | -           | 83 00      |
| 15      | Back space | 0E 08      | 0E 08      | 0E 08     | 0E 08 | 0E 7F       | -          |
|         |            | 0E 08      | 0E 08      | 0E 08     | 0E 08 | 0E 7F       | 0E 00      |
| 16      | Tab        | 0F 09      | 0F 00      | 0F 09     | 0F 00 | -           | -          |
|         |            | 0F 09      | 0F 00      | 0F 09     | 0F 00 | 94 00       | A5 00      |
| 17      | Q          | 10 71      | 10 51      | 10 51     | 10 71 | 10 11       | 10 00      |
|         |            | 10 71      | 10 51      | 10 51     | 10 71 | 10 11       | 10 00      |
| 18      | W          | 11 77      | 11 57      | 11 57     | 11 77 | 11 17       | 11 00      |
|         |            | 11 77      | 11 57      | 11 57     | 11 77 | 11 17       | 11 00      |
| 19      | E          | 12 65      | 12 45      | 12 45     | 12 65 | 12 05       | 12 00      |
|         |            | 12 65      | 12 45      | 12 45     | 12 65 | 12 05       | 12 00      |
| 20      | R          | 13 72      | 13 52      | 13 52     | 13 72 | 13 12       | 13 00      |
|         |            | 13 72      | 13 52      | 13 52     | 13 72 | 13 12       | 13 00      |
| 21      | T          | 14 74      | 14 54      | 14 54     | 14 74 | 14 14       | 14 00      |
|         |            | 14 74      | 14 54      | 14 54     | 14 74 | 14 14       | 14 00      |
| 22      | Y          | 15 79      | 15 59      | 15 59     | 15 79 | 15 19       | 15 00      |
|         |            | 15 79      | 15 59      | 15 59     | 15 79 | 15 19       | 15 00      |
| 23      | U          | 16 75      | 16 55      | 16 55     | 16 75 | 16 15       | 16 00      |
|         |            | 16 75      | 16 55      | 16 55     | 16 75 | 16 15       | 16 00      |

Table D-1 KB code to ASCII code conversion table (continued)

| Cap No. | Key Top   | Lower Case | Upper Case | Caps Lock |       | With (Ctrl) | With (Alt) |
|---------|-----------|------------|------------|-----------|-------|-------------|------------|
|         |           |            |            | Lower     | Upper |             |            |
| 24      | I         | 17 69      | 17 49      | 17 49     | 17 69 | 17 09       | 17 00      |
|         |           | 17 69      | 17 49      | 17 49     | 17 69 | 17 09       | 17 00      |
| 25      | O         | 18 6F      | 18 4F      | 18 4F     | 18 6F | 18 0F       | 18 00      |
|         |           | 18 6F      | 18 4F      | 18 4F     | 18 6F | 18 0F       | 18 00      |
| 26      | P         | 19 70      | 19 50      | 19 50     | 19 70 | 19 10       | 19 00      |
|         |           | 19 70      | 19 50      | 19 50     | 19 70 | 19 10       | 19 00      |
| 27      | {         | 1A 5B      | 1A 7B      | 1A 5B     | 1A 7B | 1A 1B       | -          |
|         |           | [          | 1A 7B      | 1A 5B     | 1A 7B | 1A 1B       | 1A 00      |
| 28      | }         | 1B 5D      | 1B 7D      | 1B 5D     | 1B 7D | 1B 1D       | -          |
|         |           | ]          | 1B 7D      | 1B 5D     | 1B 7D | 1B 1D       | 1B 00      |
| 29      |           | 2B 5C      | 2B 7C      | 2B 5C     | 2B 7C | 2B 1C       | -          |
|         |           | \          | 2B 7C      | 2B 5C     | 2B 7C | 2B 1C       | 2B 00      |
| 30      | Caps Lock | -          | -          | -         | -     | -           | -          |
|         |           | -          | -          | -         | -     | -           | -          |
| 31      | A         | 1E 61      | 1E 41      | 1E 41     | 1E 61 | 1E 01       | 1E 00      |
|         |           | 1E 61      | 1E 41      | 1E 41     | 1E 61 | 1E 01       | 1E 00      |
| 32      | S         | 1F 73      | 1F 53      | 1F 53     | 1F 73 | 1F 13       | 1F 00      |
|         |           | 1F 73      | 1F 53      | 1F 53     | 1F 73 | 1F 13       | 1F 00      |
| 33      | D         | 20 64      | 20 44      | 20 44     | 20 64 | 20 04       | 20 00      |
|         |           | 20 64      | 20 44      | 20 44     | 20 64 | 20 04       | 20 00      |
| 34      | F         | 21 66      | 21 46      | 21 46     | 21 66 | 21 06       | 21 00      |
|         |           | 21 66      | 21 46      | 21 46     | 21 66 | 21 06       | 21 00      |
| 35      | G         | 22 67      | 22 47      | 22 47     | 22 67 | 22 07       | 22 00      |
|         |           | 22 67      | 22 47      | 22 47     | 22 67 | 22 07       | 22 00      |
| 36      | H         | 23 68      | 23 48      | 23 48     | 23 68 | 23 08       | 23 00      |
|         |           | 23 68      | 23 48      | 23 48     | 23 68 | 23 08       | 23 00      |
| 37      | J         | 24 6A      | 24 4A      | 24 4A     | 24 6A | 24 0A       | 24 00      |
|         |           | 24 6A      | 24 4A      | 24 4A     | 24 6A | 24 0A       | 24 00      |
| 38      | K         | 25 6B      | 25 4B      | 25 4B     | 25 6B | 25 0B       | 25 00      |
|         |           | 25 6B      | 25 4B      | 25 4B     | 25 6B | 25 0B       | 25 00      |
| 39      | L         | 26 6C      | 26 4C      | 26 4C     | 26 6C | 26 0C       | 26 00      |
|         |           | 26 6C      | 26 4C      | 26 4C     | 26 6C | 26 0C       | 26 00      |
| 40      | :         | 27 3B      | 27 3A      | 27 3B     | 27 3A | -           | -          |
|         |           | ;          | 27 3A      | 27 3B     | 27 3A | -           | 27 00      |
| 41      | "         | 28 27      | 28 22      | 28 27     | 28 22 | -           | -          |
|         |           | '          | 28 22      | 28 27     | 28 22 | -           | 28 00      |
| 43      | Enter     | 1C 0D      | 1C 0D      | 1C 0D     | 1C 0D | 1C 0A       | -          |
|         |           | 1C 0D      | 1C 0D      | 1C 0D     | 1C 0D | 1C 0A       | 1C 00      |
| 44      | Shift (L) | -          | -          | -         | -     | -           | -          |
|         |           | -          | -          | -         | -     | -           | -          |
| 45      | \         | 56 5C      | 56 7C      | 56 5C     | 56 7C | -           | -          |
|         |           |            | 56 7C      | 56 5C     | 56 7C | -           | -          |
| 46      | Z         | 2C 7A      | 2C 5A      | 2C 5A     | 2C 7A | 2C 1A       | 2C 00      |
|         |           | 2C 7A      | 2C 5A      | 2C 5A     | 2C 7A | 2C 1A       | 2C 00      |
| 47      | X         | 2D 78      | 2D 58      | 2D 58     | 2D 78 | 2D 18       | 2D 00      |
|         |           | 2D 78      | 2D 58      | 2D 58     | 2D 78 | 2D 18       | 2D 00      |

Table D-1 KB code to ASCII code conversion table (continued)

| Cap No. | Key Top   | Lower Case | Upper Case | Caps Lock |       | With (Ctrl) | With (Alt) |
|---------|-----------|------------|------------|-----------|-------|-------------|------------|
|         |           |            |            | Lower     | Upper |             |            |
| 48      | C         | 2E 63      | 2E 43      | 2E 43     | 2E 63 | 2E 03       | 2E 00      |
|         |           | 2E 63      | 2E 43      | 2E 43     | 2E 63 | 2E 03       | 2E 00      |
| 49      | V         | 2F 76      | 2F 56      | 2F 56     | 2F 76 | 2F 16       | 2F 00      |
|         |           | 2F 76      | 2F 56      | 2F 56     | 2F 76 | 2F 16       | 2F 00      |
| 50      | B         | 30 62      | 30 42      | 30 42     | 30 62 | 30 02       | 30 00      |
|         |           | 30 62      | 30 42      | 30 42     | 30 62 | 30 02       | 30 00      |
| 51      | N         | 31 6E      | 31 4E      | 31 4E     | 31 6E | 31 0E       | 31 00      |
|         |           | 31 6E      | 31 4E      | 31 4E     | 31 6E | 31 0E       | 31 00      |
| 52      | M         | 32 6D      | 32 4D      | 32 4D     | 32 6D | 32 0D       | 32 00      |
|         |           | 32 6D      | 32 4D      | 32 4D     | 32 6D | 32 0D       | 32 00      |
| 53      | <<br>,    | 33 2C      | 33 3C      | 33 2C     | 33 3C | -           | -          |
|         |           | 33 2C      | 33 3C      | 33 2C     | 33 3C | -           | 33 00      |
| 54      | ><br>.    | 34 2E      | 34 3E      | 34 2E     | 34 3E | -           | -          |
|         |           | 34 2E      | 34 3E      | 34 2E     | 34 3E | -           | 34 00      |
| 55      | ?<br>/    | 35 2F      | 35 3F      | 35 2F     | 35 3F | -           | -          |
|         |           | 35 2F      | 35 3F      | 35 2F     | 35 3F | -           | 35 00      |
| 57      | Shift (R) | -          | -          | -         | -     | -           | -          |
|         |           | -          | -          | -         | -     | -           | -          |
| 58      | Ctrl (L)  | -          | -          | -         | -     | -           | -          |
|         |           | -          | -          | -         | -     | -           | -          |
| 60      | Alt (L)   | -          | -          | -         | -     | -           | -          |
|         |           | -          | -          | -         | -     | -           | -          |
| 61      | Space     | 30 20      | 39 20      | 39 20     | 39 20 | 39 20       | 39 20      |
|         |           | 39 20      | 39 20      | 39 20     | 39 20 | 39 20       | 39 20      |
| 62      | Alt Gr    | -          | -          | -         | -     | -           | -          |
|         |           | -          | -          | -         | -     | -           | -          |
| 75      | Ins       | 52 00      | 52 00      | 52 00     | 52 00 | -           | -          |
|         |           | 52 E0      | 52 E0      | 52 E0     | 52 E0 | 92 E0       | A2 00      |
| 76      | Del       | 53 00      | 53 00      | 53 00     | 53 00 | -           | -          |
|         |           | 53 E0      | 53 E0      | 53 E0     | 53 E0 | 93 E0       | A3 00      |
| 79      |           | 4B 00      | 4B 00      | 4B 00     | 4B 00 | 73 00       | -          |
|         |           | 4B E0      | 4B E0      | 4B E0     | 4B E0 | 73 E0       | 9B 00      |
| 80      | Home      | 47 00      | 47 00      | 47 00     | 47 00 | 77 00       | -          |
|         |           | 47 E0      | 47 E0      | 47 E0     | 47 E0 | 77 E0       | 97 00      |
| 81      | End       | 4F 00      | 4F 00      | 4F 00     | 4F 00 | 75 00       | -          |
|         |           | 4F E0      | 4F E0      | 4F E0     | 4F E0 | 75 E0       | 9F 00      |
| 83      |           | 48 00      | 48 00      | 48 00     | 48 00 | -           | -          |
|         |           | 48 E0      | 48 E0      | 48 E0     | 48 E0 | 8D E0       | 98 00      |
| 84      |           | 50 00      | 50 00      | 50 00     | 50 00 | -           | -          |
|         |           | 50 E0      | 50 E0      | 50 E0     | 50 E0 | 91 E0       | A0 00      |
| 85      | PgUp      | 49 00      | 49 00      | 49 00     | 49 00 | 84 00       | -          |
|         |           | 49 E0      | 49 E0      | 49 E0     | 49 E0 | 84 E0       | 99 00      |
| 86      | PgDn      | 51 00      | 51 00      | 51 00     | 51 00 | 76 00       | -          |
|         |           | 51 E0      | 51 E0      | 51 E0     | 51 E0 | 76 E0       | A1 00      |
| 89      | →         | 4D 00      | 4D 00      | 4D 00     | 4D 00 | 74 00       | -          |
|         |           | 4D E0      | 4D E0      | 4D E0     | 4D E0 | 74 E0       | 9D 00      |

Table D-1 KB code to ASCII code conversion table (continued)

| Cap No. | Key Top     | Lower Case | Upper Case | Caps Lock |       | With (Ctrl) | With (Alt) |
|---------|-------------|------------|------------|-----------|-------|-------------|------------|
|         |             |            |            | Lower     | Upper |             |            |
| 110     | Esc         | 01 1B      | 01 1B      | 01 1B     | 01 1B | 01 1B       | -          |
|         |             | 01 1B      | 01 1B      | 01 1B     | 01 1B | 01 1B       | 01 00      |
| 112     | F1          | 3B 00      | 54 00      | 3B 00     | 54 00 | 5E 00       | 68 00      |
|         |             | 3B 00      | 54 00      | 3B 00     | 54 00 | 5E 00       | 68 00      |
| 113     | F2          | 3C 00      | 55 00      | 3C 00     | 55 00 | 5F 00       | 69 00      |
|         |             | 3C 00      | 55 00      | 3C 00     | 55 00 | 5F 00       | 69 00      |
| 114     | F3          | 3D 00      | 56 00      | 3D 00     | 56 00 | 60 00       | 6A 00      |
|         |             | 3D 00      | 56 00      | 3D 00     | 56 00 | 60 00       | 6A 00      |
| 115     | F4          | 3E 00      | 57 00      | 3E 00     | 57 00 | 61 00       | 6B 00      |
|         |             | 3E 00      | 57 00      | 3E 00     | 57 00 | 61 00       | 6B 00      |
| 116     | F5          | 3F 00      | 58 00      | 3F 00     | 58 00 | 62 00       | 6C 00      |
|         |             | 3F 00      | 58 00      | 3F 00     | 58 00 | 62 00       | 6C 00      |
| 117     | F6          | 40 00      | 59 00      | 40 00     | 59 00 | 63 00       | 6D 00      |
|         |             | 40 00      | 59 00      | 40 00     | 59 00 | 63 00       | 6D 00      |
| 118     | F7          | 41 00      | 5A 00      | 41 00     | 5A 00 | 64 00       | 6E 00      |
|         |             | 41 00      | 5A 00      | 41 00     | 5A 00 | 64 00       | 6E 00      |
| 119     | F8          | 42 00      | 5B 00      | 42 00     | 5B 00 | 65 00       | 6F 00      |
|         |             | 42 00      | 5B 00      | 42 00     | 5B 00 | 65 00       | 6F 00      |
| 120     | F9          | 43 00      | 5C 00      | 43 00     | 5C 00 | 66 00       | 70 00      |
|         |             | 43 00      | 5C 00      | 43 00     | 5C 00 | 66 00       | 70 00      |
| 121     | F10         | 44 00      | 5D 00      | 44 00     | 5D 00 | 67 00       | 71 00      |
|         |             | 44 00      | 5D 00      | 44 00     | 5D 00 | 67 00       | 71 00      |
| 122     | F11         | -          | -          | -         | -     | -           | -          |
|         |             | 85 00      | 87 00      | 85 00     | 87 00 | 89 00       | 8B 00      |
| 123     | F12         | -          | -          | -         | -     | -           | -          |
|         |             | 86 00      | 88 00      | 86 00     | 88 00 | 8A 00       | 8C 00      |
| 124     | PrtSc       | -          | -          | -         | -     | 72 00       | -          |
|         |             | -          | -          | -         | -     | 72 00       | -          |
| 125     | Scroll Lock | -          | -          | -         | -     | -           | -          |
|         |             | -          | -          | -         | -     | -           | -          |
| 126     | Pause       | -          | -          | -         | -     | 00 00       | -          |
|         |             | -          | -          | -         | -     | 00 00       | -          |

---

# Appendix E Keyboard Layouts

---

## E.1 USA Keyboard

*Figure E-1 USA keyboard*

## E.2 UK Keyboard

*Figure E-2 UK keyboard*

### **E.3 German Keyboard**

*Figure E-3 German keyboard*

### **E.4 French Keyboard**

*Figure E-4 French keyboard*

## **E.5 Spanish and Latin American Keyboard**

*Figure E-5 Spanish and Latin American keyboard*

## **E.6 Italian Keyboard**

*Figure E-6 Italian keyboard*



## **E.7 Scandinavian (DK, NO, SW) Keyboard**

*Figure E-7 Scandinavian (DK, NO, SW) keyboard*

## **E.8 Swiss (French/German) Keyboard**

*Figure E-8 Swiss (French/German) keyboard*

# Appendix F Wiring Diagrams

## F.1 Printer Wraparound Connector

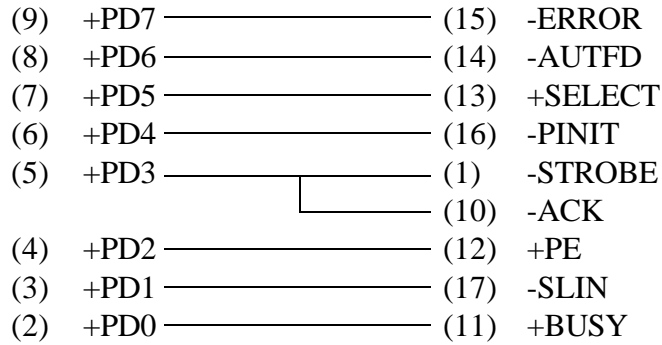

Figure F-1 Printer wraparound connector

## F.2 RS-232-C Wraparound Connector

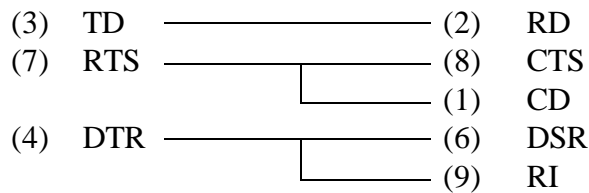

Figure F-2 RS-232-C wraparound connector

## F.3 RS-232-C Direct Cable (9-Pin to 9-Pin)

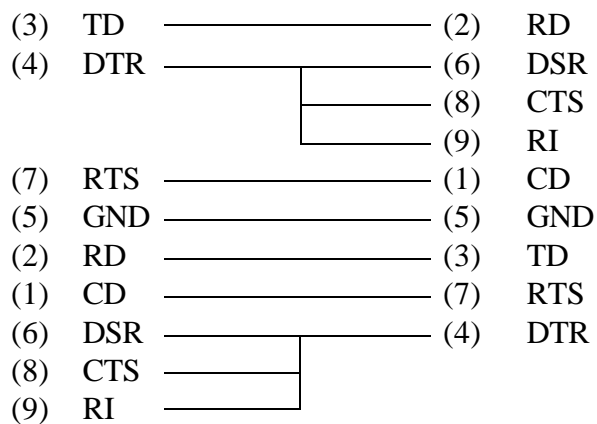
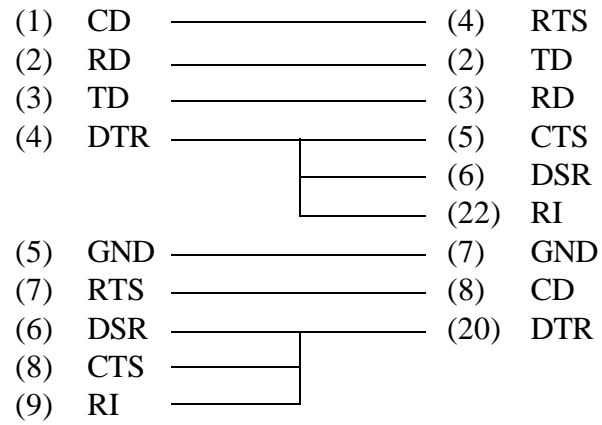

Figure F-3 RS-232-C direct cable (9-pin to 9-pin)

#### F.4 RS-232-C Direct Cable (9-Pin to 25-Pin)



*Figure F-4 RS-232-C direct cable (9-pin to 25-pin)*

# T6400 NOTES

**Inside Back Cover**  
**Replace with blank page**



Toshiba America Information Systems, Inc.  
Computer Systems Division  
9740 Irvine Boulevard  
P.O. Box 19724  
Irvine, CA 92713-9724